

**AIRDROP OF SUPPLIES AND EQUIPMENT:
RIGGING FUEL DRUMS**



DISTRIBUTION RESTRICTION: Approved for public release; distribution is unlimited.

**HEADQUARTERS
DEPARTMENTS OF THE ARMY AND THE AIR FORCE**

**CHANGE
NO. 1**

C1, FM 10-564/TO 13C7-37-1

DEPARTMENT OF THE ARMY
AND THE AIR FORCE
Washington, DC, 4 December 1981

AIRDROP OF SUPPLIES AND EQUIPMENT RIGGING AIR FUEL DRUMS

FM 10-564/TO 13C7-37-1, 16 April 1979, is changed as follows:

1. Remove old pages and insert new pages as identified below:

<u>Remove Old Pages</u>	<u>Insert New Pages</u>
ii through iv	ii through v
1-1	1-1
2-3 and 2-4	2-3 and 2-4
2-13 through 2-18	2-13 through 2-18
2-25 through 2-27	2-25 through 2-35
A-1	A-1

2. New or changed material is identified by a vertical bar in the margin opposite the changed material.
3. File this transmittal sheet in front of the publication for reference purposes.

DISTRIBUTION RESTRICTION: Approved for public release; distribution is unlimited.

By Order of the Secretaries of the Army and the Air Force:

E.C. MEYER
General, United States Army
Chief of Staff

Official:

ROBERT M. JOYCE
Major General, United States Army
The Adjutant General

DISTRIBUTION:

Active Army, USAR, and ARNG: To be distributed in accordance with DA Form 12-11A, requirements for Airdrop of Supplies and Equipment (Qty rqr block no. 228).

Additional copies may be requisitioned from the US Army Adjutant General Publications Center, 2800 Eastern Boulevard, Baltimore, MD 21220.

**CHANGE
NO. 2**

C2, FM 10-564/TO 13C7-37-1

DEPARTMENT OF THE ARMY
AND THE AIR FORCE
Washington, DC, 5 April 1983

AIRDROP OF SUPPLIES AND EQUIPMENT RIGGING AIR FUEL DRUMS

This change adds the procedures for rigging three fuel drums without a pumping assembly on a modular platform. In addition, it deletes the use of 8-foot slings.

FM 10-564/TO 13C7-37-1, 16 April 1979, is changed as follows:

1. Remove old pages and insert new pages as identified below:

<u>Remove Old Pages</u>	<u>Insert New Pages</u>
i through v	i through v
1-1	1-1
2-1 and 2-4	2-1 and 2-4
2-9 through 2-18	2-9 through 2-18
2-23 through 2-28	2-23 through 2-28
2-31 through 2-35	2-31 through 2-47
B-1 through B-3	B-1 through B-2

2. New or changed material is identified by a vertical bar in the margin opposite the changed material.
3. File this transmittal sheet in front of the publication for reference purposes.

DISTRIBUTION RESTRICTION: Approved for public release; distribution is unlimited.

By Order of the Secretaries of the Army and the Air Force:

E.C. MEYER
General, United States Army
Chief of Staff

Official:

ROBERT M. JOYCE
Major General, United States Army
The Adjutant General

DISTRIBUTION:

Active Army, USAR, and ARNG: To be distributed in accordance with DA Form 12-11A, requirements for Airdrop of Supplies and Equipment (Qty rqr block no. 228).

Additional copies may be requisitioned from the US Army Adjutant General Publications Center, 2800 Eastern Boulevard, Baltimore, MD 21220.

**CHANGE
No 3**

C3, FM 10-564/TO 13C7-37-1
HEADQUARTERS
DEPARTMENT OF THE ARMY
AND THE AIR FORCE
Washington, DC, 11 August 1986

**AIRDROP OF SUPPLIES AND EQUIPMENT:
RIGGING AIR FUEL DRUMS**

This change authorizes the airdrop of diesel fuel and adds the procedures for using the M-1 release on the six-sling load.

FM 10-564/TO 13C7-37-1, 16 April 1979, is changed as follows:

1. New or changed material is identified by a vertical bar in the margin opposite the changed material.
2. Remove old pages and insert new pages as identified below:

Remove Old Pages

Insert New Pages

1-1
2-43 through 2-46

1-1
2-43 through 2-46

3. File this transmittal sheet in front of the publication for reference purposes.

DISTRIBUTION RESTRICTION: Approved for public release; distribution is unlimited.

By Order of the Secretaries of the Army and the Air Force:

JOHN A. WICKHAM, JR.
General, United States Army
Chief of Staff

Official:

R. L. DILWORTH
Brigadier General, United States Army
The Adjutant General

DISTRIBUTION:

Active Army, USAR, and ARNG: To be distributed in accordance with DA Form 12-11A, Requirements for Airdrop-Rigging Fuel Drums (Qty rqr block no. 940).

**CHANGE
No 4**

C4, FM 10-564/TO 13C7-37-1

DEPARTMENT OF THE ARMY
AND THE AIR FORCE
Washington, DC, 27 March 1990

AIRDROP OF SUPPLIES AND EQUIPMENT RIGGING FUEL DRUMS

This change adds the procedures for rigging fuel drums on a type V platform for low-velocity and LAPE airdrop.

FM 10-564/TO 13C7-37-1, 16 April 1979, is changed as follows:

1. New or changed material is identified by a vertical bar in the margin opposite the changed material.
2. Remove old pages and insert new pages as identified below:

Remove Old Pages

i through v
1-1

A-1

Insert New Pages

i through iv
1-1
4-1 through 4-30
5-1 through 5-18

Glossary-1
References-1

3. File this transmittal sheet in front of the publication for reference purposes.

DISTRIBUTION RESTRICTION: Approved for public release; distribution is unlimited.

By Order of the Secretaries of the Army and the Air Force:

CARL E. VUONO
General, United States Army
Chief of Staff

Official:

WILLIAM J. MEEHAN II
Brigadier General, United States Army
The Adjutant General

DISTRIBUTION:

Active Army, USAR, and ARNG: To be distributed in accordance with DA Form 12-11E, Requirements for FM 10-564, Airdrop of Supplies and Equipment: Rigging Fuel Drums (Qty rqr block no. 940).

**CHANGE
NO 5**

C5, FM 10-564/TO 13C7-37-1
HEADQUARTERS
DEPARTMENT OF THE ARMY
AND THE AIR FORCE
Washington, DC, 27 March 1990

AIRDROP OF SUPPLIES AND EQUIPMENT RIGGING FUEL DRUMS

This change adds the procedures for rigging three, four, and five fuel drums on a type V platform for LAPE airdrop. Also with this change, the distribution statement and the destruction notice shown below must be added to the cover of the basic manual.

FM 10-564/TO 13C7-37-1, 16 April 1979, is changed as follows:

1. New or changed material is identified by a vertical bar in the margin opposite the changed material.
2. Remove old pages and insert new pages as identified below:

Remove Old Pages

i through iv
1-1
5-1 and 5-2
5-17 and 5-18
References-1

Insert New Pages

i through v
1-1
5-1 and 5-2
5-17 through 5-96
References-1

3. File this transmittal sheet in front of the publication for reference purposes.

DISTRIBUTION RESTRICTION: Approved for public release; distribution is unlimited.

By Order of the Secretaries of the Army and the Air Force:

GORDON R. SULLIVAN
General, United States Army
Chief of Staff

Official:

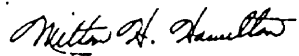

MILTON H. HAMILTON
Administrative Assistant to the
Secretary of the Army
02992

DISTRIBUTION:

Active Army, USAR, and ARNG: To be distributed in accordance with DA Form 12-11-E, Requirements for FM 10-564, Airdrop of Supplies and Equipment: Rigging Fuel Drums (Qty rqr block no. 0940).



DEPARTMENT OF THE ARMY

HEADQUARTERS UNITED STATES ARMY TRAINING AND DOCTRINE COMMAND
FORT MONROE, VIRGINIA 23651-5000

REPLY TO
ATTENTION OF

ATCD-SL (70-1f)

21 Oct 96

MEMORANDUM FOR DEPUTY CHIEF OF STAFF OPERATIONS AND PLANS,
400 ARMY PENTAGON, ATTN: DAMO-FDL, WASHINGTON
DC 20310-0400

SUBJECT: Quartermaster (QM) Functional Area Assessment (FAA)
Response

1. References:

a. Message, HQDA, DAMO-FDL, 231825Z Apr 96, subject: QM FAA Results.

b. Memorandum, HQ TRADOC, ATCG, 29 Jul 96, Army Airdrop Capabilities Assessment.

2. At the 29 Mar 96 QM FAA briefing to the Director of Army Staff, the decision was reached to revisit the Army's decision to "shelf" Low Altitude Parachute Extraction System (LAPES) (reference 1a).

a. Reference 1b, solicited CINCs input for their positions on LAPES and assessments of airdrop capabilities. The CINCs responses will be used to chart the direction and role for airdrop in the 21st century.

b. Based on the responses received (enclosure), there is no strong support for LAPES airdrop capability at this time. The consensus for the airdrop capabilities is to continue support for current Low Velocity Airdrop System (LVAD), develop a 500-foot LVAD and further explore Advanced Precision Aerial Delivery System (APADS).

3. Further, we will continue to maintain a range of airdrop capabilities to support all contingencies throughout the Army. The results of the Army Airdrop Capabilities Assessment also will be incorporated into the Operational Concept for Aerial Delivery Operations and Improved Cargo Aerial Delivery Capability Mission Needs Statement being developed by the Quartermaster Directorate of Combat Developments, U.S. Army Combined Arms Support Command (CASCOM).

4. The HQ TRADOC POC is MAJ Higgins, Airborne Airlift Action Office, ATCD-SL, E-mail: higginsn@emh10.monroe.army.mil, DSN 680-2469/3921, datafax DSN 680-2520.

ATCD-SL

SUBJECT: Quartermaster (QM) Functional Area Assessment (FAA)
Response

FOR THE DEPUTY CHIEF OF STAFF FOR COMBAT DEVELOPMENTS:

Encl

JOHN A. MANDEVILLE
Colonel, GS
Director, Combat Service Support

CF:

USACASCOM (ATCL-CG/ATCL-QC/ATCL-MES)

USAQMC&S (ATSM-CG/ATSM-ABN/FS)

USANRDEC (SSCNC-UT/AMSSC-PM)

ORGANIZATION	LAPES	LVAD	500' LVAD	APADS	SPTS/ NOT SPEC
USSOCOM		X	X	X	
EUCCOM					X
CENTCOM		X	X		
FORSCOM		X	X	X	
TRANSCOM					X
SOUTHCOM	X			X	
VIII ARMY					X
ACOM					X

USSOCOM: Memorandum specifically states that the command does not support LAPES airdrop capability, but supports LVAD as well as APADS.

EUCCOM: Draft memorandum specifically states that the command support the need for a low level airdrop capability. However, memorandum summarizes that the specific capability is not important as to have a capability to meet the required mission/threat profile.

CENTCOM: Memorandum specifically states that the command does not support LAPES airdrop capability, but support both current LVAD and 500-foot LVAD airdrop capabilities.

FORSCOM: 1st Endorsement specifically states that the command does not support LAPES airdrop capability, however supports LVAD, 500-foot LVAD and APADS.

TRANSCOM: Memorandum does not specifically address any airdrop capability as it talks to the 21st century requiring the full spectrum of tactical delivery methods.

SOUTHCOM: Memorandum specifically supports LAPES and APADS airdrop capabilities for their command.

VIII ARMY: E-Mail note for VIII Army states that the command has no input to the assessment as their plans call for a limited employment of airdrop.

ACOM: Sent request for input on 30 Sep 96. Received verbal response on 16 Oct 96 stating command is indifferent on the specific capability received.



DEPARTMENT OF THE ARMY
HEADQUARTERS UNITED STATES ARMY TRAINING AND DOCTRINE COMMAND
FORT MONROE, VIRGINIA 23651-3000

REPLY TO
ATTENTION OF

6 SEP 1995

ATCD-SL (70-1f)

MEMORANDUM FOR

Major General Thomas W. Robison, Commander, U.S. Army Combined
Arms Support Command and Fort Lee, Fort Lee, VA 23801-6000
Major General Robert K. Guest, Commander, U.S. Army Quartermaster
Center and School, Fort Lee, VA 23801-5030

SUBJECT: Low Altitude Parachute Extraction System (LAPES)
Disassembly.

1. References:

a. Message, HQ TRADOC, ATCD-SL, 100930Z Jan 95, subject:
LAPES.

b. OVVM Note, HQ USACASCOM, 30 March 95, subject: TRADOC
Disassembly of LAPES.

2. The U.S. Army and other services recently have concurred that
LAPES will be terminated, as this capability is no longer required
as a viable wartime contingency airdrop option. However,
Headquarters, Department of the Army (DA), Deputy Chief of Staff
for Operations and Plans, has agreed that LAPES technology will be
shelved, and all specialized equipment preserved for possible
future use.

3. Take the necessary steps to terminate training and leader
development concerning LAPES operations. Major General Guest's
questions regarding the disassembly of LAPES (enclosed) with
following guidance will be utilized:

a. "Does the U.S. Army Quartermaster Center and School
(USAQMC&S) continue to publish LAPES procedures in their joint
field manual (FMs)/technical order manuals?" "Do we publish the
LAPES procedures that have been written but not been printed yet?"
Publishing LAPES procedures in all joint publications, Army FMs,
regulations, etc., will be discontinued and addressed in the next
revision of the aforementioned documents. Concurrently, all LAPES
procedures that have been written and not printed will not be
published.

6 SEP 1995

ATCD-SL
SUBJECT: Low Altitude Parachute Extraction System (LAPES)
Disassembly

b. "Do we keep LAPES in our programs of instruction (POIs)?" "Do we teach LAPES to other services and our allies?" The USAQMC&S will remove LAPES procedures from PCI and cease teaching LAPES to other services and/or allies.

c. "What do we teach to folks that have LAPES equipment in their war reserves?" All instruction concerning LAPES procedures will be discontinued whether LAPES equipment is located in units or in war reserves.

d. "What is the DA/TRADOC guidance on disposition of unit, depot, and war reserves LAPES equipment?" All LAPES equipment in war reserves and depot should be preserved with the exception of a few items that can be utilized in other existing airdrop capabilities. Specifically, the Type V airdrop platforms and attitude control bars of the LAPES system are being utilized to augment current Low Velocity Airdrop Systems (LVADS) loads.

e. "What is the guidance to U.S. Army Test and Experimentation Command on force development test and experimentation certification of LAPES loads?" The certification of all LAPES loads at the Airborne Special Operations Test Directorate will be redirected toward testing and certification of LVADS loads.

4. HQ TRADOC POC is CPT Higgins or CPT Phillips, ATCD-SL, DSN 680-2469/3921, datafax DSN 680-2520.

FOR THE COMMANDER:

Encl

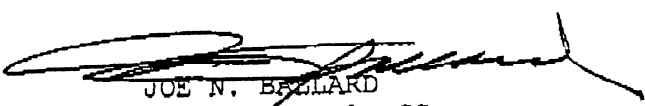

JOE N. BALLARD
Major General, GS
Chief of Staff

CF:
HQDA (DAMO-FDL)
CDR, NRDEC (SAFNC-UA)
CDR, FORSCOM (FCJ3-FC)
CDR, OPTEC (CSTE-CS, CSTE-OPM)
CDR, ATCOM (AMSAT-W-TD)
DIR, ABNSOTD (ATCT-AB)
HQ TRADOC (ATCD-L, ATCD-RM, ATDO-A, ATTG-IT)

Date and time 07/18/95 10:28:11

From: HIGGINSN--MON1
To: HIGGINSN--MON1

From: OPT NEIL HIGGINS, (AAACO), 680-2469
Subject: TRADOC "DISASSEMBLY" OF LAPES

* AIRBORNE AIRLIFT ACTION OFFICE *
* (AAACO) *

** Forwarding note from BRUNEAUN--OMSNAMES 07/18/95 10:27 ***
Received: from LEE-EMH2.ARMY.MIL by MONROE-EMH2.ARMY.MIL (IBM VM SMTP V2R2)
with TOP; Tue, 18 Jul 95 10:27:22 EDT
Received: from LEE1 by LEE-EMH2.ARMY.MIL (IBM VM SMTP V2R2) with SMTP id 3547;
Tue, 18 Jul 95 10:29:34 EDT
Comments: Converted from PROFS to RFC822 format by PUMP V2.2X
Date: Tue, 18 Jul 95 10:29:26 EDT
From: NORMAN BRUNEAU <BRUNEAUN@LEE-EMH2.ARMY.MIL>
Subject: TRADOC "DISASSEMBLY" OF LAPES
To: "NEIL HIGGINS- AAACO " <HIGGIN@MONROE-EMH1.ARMY.MIL>

** Resending note of 06/30/95 09:23

From: LARRY MC MILLIAN AAA <MCILLI@MONROE-EMH1.ARMY.MIL>
To: NORMAN BRUNEAU
Subject: TRADOC "DISASSEMBLY" OF LAPES

NEIL- HERE ARE THE QUESTIONS THAT MG GUEST WANTS DA/ TRADOC TO ANSWER RE LAPES, AS I UNDERSTAND HIS GUIDANCE. I HAVE DISCUSSED THESE W/ OUR ABN DPT. IF THESE QUESTIONS MAKE SENSE, GIVE ME AN "UP" BEFORE I FORMALLY SEND ANYTHING OUT. MG GUEST WANTS SPECIFIC GUIDANCE FM TRADOC ON LAPES, RESPONSE NEEDS TO BE CLEAR AND TO THE POINT. A LOT OF THIS WILL HINGE ON WHAT ACC PLANS TO DO W/ LAPES NOW THAT THE AIR STAFF HAS GIVEN THEM THE GREEN LIGHT TO KILL IT. IF THEY PLAN TO PLACE IT ON THE SHELF OR KEEP A LIMITED OR CONTINGENCY CAPABILITY, THAT WILL DRIVE YOUR ANSWER TO US, AT THIS POINT I THINK ACC WILL DO WHATEVER THE ARMY WANTS, AS THEIR PRIMARY CUSTOMER. I WILL NOT REHASH HOW THE ARMY DECIDED THEY DIDNT NEED LAPES. QUESTIONS FOLLOW:

- DOES THE GMS CONTINUE TO PUBLISH LAPES PROCEDURES IN THEIR JOINT FM/TO MANUALS?
- DO WE PUBLISH THE LAPES PROCEDURES THAT HAVE BEEN WRITTEN BUT HAVE NOT BEEN PRINTED YET?
- DO WE REMOVE ALL LAPES PROCEDURES FROM ALREADY PUBLISHED MANUALS?
- DO WE KEEP LAPES IN OUR POI?
- DO WE TEACH LAPES TO OTHER SERVICES AND OUR ALLIES?
- WHAT DO WE TEACH TO FOLKS THAT HAVE LAPES EQUIPMENT IN THEIR WAR RESERVES?
- WHAT IS THE DA/TRADOC GUIDANCE ON DISPOSITION OF UNIT, DEPOT, AND WAR RESERVE LAPES EQUIPMENT?
- WHAT IS THE GUIDANCE TO TEXCOM ON THE FUTE CERTIFICATION OF LAPES LOADS?

I KNOW THESE ARE TOUGH QUESTIONS, BUT THEY HAVE TO BE ASKED. HQ STAFFS CANNOT SIMPLY SAY "KILL IT" AND MOVE ON TO THE NEXT ISSUE. I DONT THINK WE ARE DOING OUR JOB IF WE LEAVE IT UP TO THE SCHOOLHOUSE TO INTERPRET SKETCHY GUIDANCE. THAT PLACES US IN THE POSSIBLE POSITION OF BEING ACCUSED OF NOT FOLLOWING ORDERS.

LETS TALK.....NORM

TRK 2/47

SEP 11 11 08:30AM CSSRD FT MONROE VA 66 11

DEPARTMENT OF THE ARMY
QUARTERMASTER CENTER AND SCHOOL
1201 22D STREET
FORT LEE, VIRGINIA 23801-1601

ATSM-ABN-FS

15 Dec 96

MEMORANDUM FOR RECORD

SUBJECT: Airdrop Equipment Update

Reference:

- a. Phone conversation between CW4 Mahon, CASCOM and Dick Harper, Weapons System Management Office, Army Aviation Troop Command. Subject : sab
- b. Phone conversation between CW4 Mahon, CASCOM and Don Stump, Logistics Management Specialist, Office, Deputy Chief of Staff for Logistics. Subject. sab
- c. Phone conversation between CW4 Mahon, CASCOM and Chief Msgt Okraneck, Hqrs Air Combat Command. Subject sab
- d. msg dtg R 181348Z Feb 94. subject: FCIF item: Type II platforms, PEFTC and SL/CS for Air Force unilateral training

1. Based on information received from the references a-c above, the following update is provided per request ref c, above.
 - a. The type II modular platform no longer exists within any contingency stocks. Therefore, maintaining Joint Inspection training program is no longer required for this equipment.
 - b. The Parachute Extraction Transfer Force Coupling (PEFTC) no longer exists within any contingency stocks. Therefore, maintaining Joint Inspection training program is no longer required for this equipment.
 - c. The metric platform interim rigging procedures are no longer valid as they apply to metric platforms. Those rigging procedures which have dual application with the type V platform are still valid for the type V platform.
 - d. The static line connector strap (SL/CS) currently has limited application. Only those loads that specifically require this system are authorized use of this system. The SL/CS is not an across the board substitute for the Extraction Force Transfer Coupling (EFTC). These authorized loads are specific in nature and will normally be found in the special operations arena of airdrop loads. This system is not authorized for use IAW ref d, above.
2. For additional questions/information contact the undersigned at DSN 687-4733, Fax 3084.

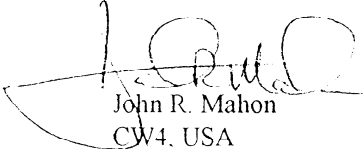
John R. Mahon
CW4, USA
Senior Airdrop Systems
Technician

CHANGE
No. 6

HEADQUARTERS
DEPARTMENT OF THE ARMY
DEPARTMENT OF THE AIR FORCE
Washington, DC, 30 January 1998

**AIRDROP OF SUPPLIES AND EQUIPMENT
RIGGING FUEL DRUMS**

This change adds the procedures for rigging four, five, six or seven fuel drums without the pumping assembly for low-velocity airdrop on a type V platform. Also, this change modifies the procedures for rigging three fuel drums without the pumping assembly on the type V platform for low-velocity airdrop. This change also adds the procedures for rigging three, six, or seven fuel drums with the pumping assembly for low-velocity airdrop on the type V platform. The distribution restriction is also changed. The destruction notice is no longer needed.

FM 10-564/TO 13C7-37-1, 16 April 1979, is changed as follows:

1. New or changed material is identified by a vertical bar (■) in the margin opposite the changed material.
2. File this transmittal page in front of the publication
3. Remove old pages and insert new pages as indicated below:

Remove pages

Cover 1
i through v
1-1
4-15 through 4-30
Glossary-1
References-1

Insert pages

Cover 1
i through ix
1-1
4-15 through 4-152
Glossary-1
References 1 and References 2

DISTRIBUTION RESTRICTION: Approved for public release; distribution is unlimited.

By Order of the Secretaries of the Army and the Air Force:

Official:

JOEL B. HUDSON
*Administrative Assistant to the
Secretary of the Army*
04301

DENNIS J. REIMER
*General, United States Army
Chief of Staff*

DISTRIBUTION:

Active Army, Army National Guard, and U.S. Army Reserve: To be distributed in accordance with the initial distribution number 110940, requirements for FM 10-564.

FIELD MANUAL
 NO 10-564
 TECHNICAL ORDER
 NO 13C7-37-1

C6, FM 10-564/TO 13C7-37-1
***FM 10-564/TO 13C7-37-1**
 HEADQUARTERS
 DEPARTMENTS OF THE ARMY
 AND THE AIR FORCE
 Washington, DC, 16 April 1979

**AIRDROP OF SUPPLIES AND EQUIPMENT:
 RIGGING FUEL DRUMS**

TABLE OF CONTENTS

	<i>Paragraph</i>	<i>Page</i>
PREFACE		ix
CHAPTER 1 INTRODUCTION		
Description of Items	1-1	1-1
Special Considerations	1-2	1-1
CHAPTER 2 RIGGING DRUMS FOR LOW-VELOCITY AIRDROP ON TYPE II PLATFORM		
Section I RIGGING TWO DRUMS WITH PUMPING ASSEMBLY		
Description of Load.....	2-1	2-1
Preparing Platform.....	2-2	2-1
Preparing Pumping Assembly.....	2-3	2-1
Lashing Container.....	2-4	2-2
Securing Plywood Protectors.....	2-5	2-2
Attaching Suspension Slings.....	2-6	2-2
Lashing Drums.....	2-7	2-2
Stowing Cargo Parachutes.....	2-8	2-2
Installing Extraction System.....	2-9	2-2
Installing Release System.....	2-10	2-2
Positioning Extraction Parachute.....	2-11	2-2
Marking Rigged Load.....	2-12	2-3
Equipment Required.....	2-13	2-3
Section II RIGGING ONE DRUM WITH PUMPING ASSEMBLY		
Description of Load.....	2-14	2-16
Preparing Platform.....	2-15	2-16
Stowing Pumping Assembly.....	2-16	2-16

DISTRIBUTION RESTRICTION: Approved for public release; distribution is unlimited.

* This manual supersedes FM 10-564/TO 13C7-37-1, 30 May 1975.

	<i>Paragraph</i>	<i>Page</i>
	Lashing Drum.....	2-17 2-16
	Stowing Cargo Parachutes.....	2-18 2-16
	Installing Extraction System.....	2-19 2-16
	Installing Release System.....	2-20 2-16
	Safetying Suspension Slings.....	2-21 2-17
	Positioning Extraction Parachute.....	2-22 2-17
	Marking Rigged Load.....	2-23 2-17
	Equipment Required.....	2-24 2-17
Section III	RIGGING TWO DRUMS WITHOUT PUMPING ASSEMBLY	
	Description of Load.....	2-25 2-28
	Preparing Platform.....	2-26 2-28
	Attaching Suspension Slings.....	2-27 2-28
	Lashing Drums.....	2-28 2-28
	Attaching Deadman's Tie	2-29 2-30
	Stowing Cargo Parachutes.....	2-30 2-31
	Installing Extraction System.....	2-31 2-31
	Installing Release System.....	2-32 2-31
	Positioning Extraction Parachute.....	2-33 2-31
	Marking Rigged Load.....	2-34 2-31
	Equipment Required.....	2-35 2-31
Section IV	RIGGING THREE DRUMS WITHOUT PUMPING ASSEMBLY	
	Description of Load.....	2-36 2-36
	Preparing Platform.....	2-37 2-36
	Preparing and Placing Honeycomb.....	2-38 2-37
	Attaching Suspension Slings.....	2-39 2-38
	Lashing Drums.....	2-40 2-38
	Attaching Deadman's Tie.....	2-41 2-40
	Stowing Cargo Parachutes.....	2-42 2-41
	Installing Extraction System.....	2-43 2-44
	Installing Release System.....	2-44 2-44
	Positioning Extraction Parachute.....	2-45 2-44
	Marking Rigged Load.....	2-46 2-44
	Equipment Required.....	2-47 2-44
CHAPTER 3	RIGGING DRUMS FOR LAPE AIRDROP	
Section I	RIGGING TWO DRUMS	
	Description of Load.....	3-1 3-1
	Preparing Platform.....	3-2 3-1
	Lashing Drums.....	3-3 3-1
	Lashing Attitude Control Bar.....	3-4 3-1
	Installing Extraction System.....	3-5 3-1
	Placing Extraction Parachute.....	3-6 3-1
	Marking Rigged Load.....	3-7 3-1
	Equipment Required.....	3-8 3-1

	<i>Paragraph</i>	<i>Page</i>
Section II	RIGGING THREE DRUMS	
	Description of Load.....	3-9 3-10
	Preparing Platform.....	3-10 3-10
	Lashing Drums.....	3-11 3-10
	Lashing Attitude Control Bar.....	3-12 3-10
	Installing Extraction System.....	3-13 3-10
	Placing Extraction Parachutes.....	3-14 3-10
	Marking Rigged Load.....	3-15 3-10
	Equipment Required.....	3-16 3-10
Section III	RIGGING FOUR DRUMS	
	Description of Load.....	3-17 3-18
	Preparing Platform.....	3-18 3-18
	Lashing Drums.....	3-19 3-18
	Lashing Attitude Control Bar.....	3-20 3-18
	Installing Extraction System.....	3-21 3-18
	Placing Extraction Parachutes.....	3-22 3-18
	Marking Rigged Load.....	3-23 3-18
	Equipment Required.....	3-24 3-18
Section IV	RIGGING FIVE DRUMS	
	Description of Load.....	3-25 3-29
	Preparing Platform.....	3-26 3-29
	Lashing Drums.....	3-27 3-29
	Lashing Attitude Control Bar.....	3-28 3-30
	Installing Extraction System.....	3-29 3-30
	Placing Extraction Parachutes.....	3-30 3-30
	Marking Rigged Load.....	3-31 3-30
	Equipment Required.....	3-32 3-30
Section V	RIGGING PUMP AND FILTER	
	General.....	3-33 3-39
	Preparing Pump and Filter.....	3-34 3-39
	Lashing Pump.. ..	3-35 3-39
	Lashing Filter.....	3-36 3-39
	Marking Rigged Load.....	3-37 3-39
	Equipment Required.....	3-38 3-39
CHAPTER 4	RIGGING DRUMS FOR LOW-VELOCITY AIRDROP ON A TYPE V PLATFORM	
Section I	RIGGING TWO DRUMS WITHOUT PUMPING ASSEMBLY ON AN 8-FOOT PLATFORM	
	Description of Load.....	4-1 4-1
	Preparing Platform.....	4-2 4-1
	Preparing and Positioning Honeycomb Stacks.....	4-3 4-3
	Installing Lifting Slings.....	4-4 4-4

	<i>Paragraph</i>	<i>Page</i>
	Positioning and Lashing Drums.....	4-5 4-5
	Installing and Safetying Suspension Slings.....	4-6 4-8
	Installing Cargo Parachutes.....	4-7 4-9
	Installing Extraction System.....	4-8 4-10
	Installing Parachute Release.....	4-9 4-11
	Placing Extraction Parachute.....	4-10 4-12
	Installing Provisions for Emergency Restraints.....	4-11 4-12
	Marking Rigged Load.....	4-12 4-12
	Equipment Required.....	4-13 4-12
Section II	RIGGING THREE DRUMS WITHOUT PUMPING	
	ASSEMBLY ON A 12-FOOT PLATFORM	
	Description of Load.....	4-14 4-16
	Preparing Platform.....	4-15 4-16
	Preparing and Positioning Honeycomb Stacks.....	4-16 4-18
	Installing Lifting Slings and Positioning Drums.....	4-17 4-19
	Lashing Drums.....	4-18 4-20
	Installing and Safetying Suspension Slings.....	4-19 4-22
	Building and Lashing Parachute Stowage Platform.....	4-20 4-23
	Installing Cargo Parachutes.....	4-21 4-24
	Installing Parachute Release.....	4-22 4-25
	Installing Extraction System.....	4-23 4-26
	Installing Provisions for Emergency Restraints.....	4-24 4-27
	Placing Extraction Parachute.....	4-25 4-27
	Marking Rigged Load.....	4-26 4-27
	Equipment Required.....	4-27 4-27
Section III	RIGGING THREE DRUMS WITH PUMPING	
	ASSEMBLY ON A 12-FOOT PLATFORM	
	Description of Load.....	4-28 4-31
	Preparing Platform.....	4-29 4-31
	Preparing and Positioning Honeycomb Stacks.....	4-30 4-33
	Installing Lifting Slings and Positioning Drums.....	4-31 4-33
	Lashing Drums.....	4-32 4-33
	Preparing Pump Assembly.....	4-33 4-35
	Lashing Pump Assembly to Platform.....	4-34 4-35
	Installing and Safetying Suspension Slings.....	4-35 4-38
	Building and Lashing Parachute Stowage Platform.....	4-36 4-38
	Installing Cargo Parachutes.....	4-37 4-38
	Installing Parachute Release.....	4-38 4-38
	Installing Extraction System.....	4-39 4-38
	Installing Provisions for Emergency Restraints.....	4-40 4-38
	Placing Extraction Parachute.....	4-41 4-38
	Marking Rigged Load.....	4-42 4-38
	Equipment Required.....	4-43 4-38

	<i>Paragraph</i>	<i>Page</i>
Section IV	RIGGING FOUR DRUMS WITHOUT PUMPING	
	ASSEMBLY ON A 20-FOOT PLATFORM	
	Description of Load.....	4-44 4-42
	Preparing Platform.....	4-45 4-42
	Preparing and Positioning Honeycomb Stacks.....	4-46 4-44
	Installing Lifting Slings and Positioning Drums.....	4-47 4-45
	Lashing Drums.....	4-48 4-45
	Installing and Safetying Suspension Slings.....	4-49 4-47
	Building and Lashing Parachute Stowage Platform.....	4-50 4-48
	Installing Cargo Parachutes.....	4-51 4-49
	Installing Parachute Release.....	4-52 4-50
	Installing Extraction System.....	4-53 4-51
	Installing Provisions for Emergency Restraints.....	4-54 4-52
	Placing Extraction Parachute.....	4-55 4-52
	Marking Rigged Load.....	4-56 4-52
	Equipment Required.....	4-57 4-52
Section V	RIGGING FIVE DRUMS WITHOUT PUMPING	
	ASSEMBLY ON A 20-FOOT PLATFORM	
	Description of Load.....	4-58 4-56
	Preparing Platform.....	4-59 4-56
	Preparing and Positioning Honeycomb Stacks.....	4-60 4-58
	Installing Lifting Slings and Positioning Drums.....	4-61 4-59
	Lashing Drums.....	4-62 4-60
	Installing and Safetying Suspension Slings.....	4-63 4-63
	Building and Lashing Parachute Stowage Platform.....	4-64 4-65
	Installing Cargo Parachutes.....	4-65 4-67
	Installing Parachute Release.....	4-66 4-68
	Installing Extraction System.....	4-67 4-69
	Installing Provisions for Emergency Restraints.....	4-68 4-70
	Placing Extraction Parachute.....	4-69 4-70
	Marking Rigged Load.....	4-70 4-70
	Equipment Required.....	4-71 4-70
Section VI	RIGGING SIX DRUMS WITHOUT PUMPING	
	ASSEMBLY ON A 24-FOOT PLATFORM	
	Description of Load.....	4-72 4-75
	Preparing Platform.....	4-73 4-75
	Preparing and Positioning Honeycomb Stacks.....	4-74 4-77
	Installing Lifting Slings and Positioning Drums.....	4-75 4-78
	Lashing Drums.....	4-76 4-79
	Installing and Safetying Suspension Slings.....	4-77 4-82
	Building and Lashing Parachute Stowage Platform.....	4-78 4-85

	<i>Paragraph</i>	<i>Page</i>
	Installing Cargo Parachutes.....	4-79 4-87
	Installing Parachute Release.....	4-80 4-88
	Installing Extraction System.....	4-81 4-89
	Installing Provisions for Emergency Restraints.....	4-82 4-90
	Placing Extraction Parachute.....	4-83 4-90
	Marking Rigged Load.....	4-84 4-90
	Equipment Required.....	4-85 4-90
Section VII	RIGGING SIX DRUMS WITH PUMPING ASSEMBLY ON A 24-FOOT PLATFORM	
	Description of Load.....	4-86 4-95
	Preparing Platform.....	4-87 4-95
	Preparing and Positioning Honeycomb Stacks.....	4-88 4-97
	Installing Lifting Slings and Positioning Drums.....	4-89 4-97
	Lashing Drums.....	4-90 4-97
	Preparing Pump Assembly.....	4-91 4-101
	Lashing Pump Assembly to Platform.....	4-92 4-101
	Installing and Safetying Suspension Slings.....	4-93 4-104
	Building and Lashing Parachute Stowage Platform.....	4-94 4-104
	Installing Cargo Parachutes.....	4-95 4-106
	Installing Parachute Release.....	4-96 4-107
	Installing Extraction System.....	4-97 4-108
	Installing Provisions for Emergency Restraints.....	4-98 4-108
	Placing Extraction Parachute.....	4-99 4-108
	Marking Rigged Load.....	4-100 4-108
	Equipment Required.....	4-101 4-108
Section VIII	RIGGING SEVEN DRUMS WITHOUT PUMPING ASSEMBLY ON A 28-FOOT PLATFORM	
	Description of Load.....	4-102 4-113
	Preparing Platform.....	4-103 4-113
	Preparing and Positioning Honeycomb Stacks.....	4-104 4-115
	Installing Lifting Slings and Positioning Drums.....	4-105 4-116
	Lashing Drums.....	4-106 4-117
	Installing and Safetying Suspension Slings.....	4-107 4-120
	Building and Lashing Parachute Stowage Platform.....	4-108 4-122
	Installing Cargo Parachutes.....	4-109 4-124
	Installing Parachute Release.....	4-110 4-125
	Installing Extraction System.....	4-111 4-126
	Installing Provisions for Emergency Restraints.....	4-112 4-127
	Placing Extraction Parachute.....	4-113 4-127
	Marking Rigged Load.....	4-114 4-127
	Equipment Required.....	4-115 4-127

	<i>Paragraph</i>	<i>Page</i>
Section IX	RIGGING SEVEN DRUMS WITH PUMPING ASSEMBLY ON A 28-FOOT PLATFORM	
	Description of Load.....	4-116 4-132
	Preparing Platform.....	4-117 4-132
	Preparing and Positioning Honeycomb Stacks.....	4-118 4-134
	Installing Lifting Slings and Positioning Drums.....	4-119 4-135
	Lashing Drums.....	4-120 4-136
	Preparing Pump Assembly.....	4-121 4-139
	Lashing Pump Assembly to Platform.....	4-122 4-139
	Installing and Safetying Suspension Slings.....	4-123 4-142
	Building and Lashing Parachute Stowage Platform.....	4-124 4-145
	Installing Cargo Parachutes.....	4-125 4-146
	Installing Parachute Release.....	4-126 4-147
	Installing Extraction System.....	4-127 4-148
	Installing Provisions for Emergency Restraints.....	4-128 4-148
	Placing Extraction Parachute.....	4-129 4-148
	Marking Rigged Load.....	4-130 4-148
	Equipment Required.....	4-131 4-148
CHAPTER 5	RIGGING DRUMS FOR LAPE AIRDROP ON A TYPE V PLATFORM	
Section I	RIGGING TWO DRUMS ON A 12-FOOT PLATFORM	
	Description of Load.....	5-1 5-1
	Preparing Platform.....	5-2 5-2
	Preparing and Positioning Deck Lashings.....	5-3 5-3
	Preparing and Positioning Honeycomb.....	5-4 5-5
	Installing Lifting Slings.....	5-5 5-6
	Positioning and Lashing Drums.....	5-6 5-6
	Lashing Drums to the Platform.....	5-7 5-11
	Installing Attitude Control Bar.....	5-8 5-13
	Installing Extraction System.....	5-9 5-15
	Placing Extraction Parachutes.....	5-10 5-17
	Marking Rigged Load.....	5-11 5-17
	Equipment Required.....	5-12 5-18
Section II	RIGGING THREE DRUMS ON A 16-FOOT PLATFORM	
	Description of Load.....	5-13 5-20
	Preparing Platform.....	5-14 5-20
	Preparing and Positioning Deck Lashings.....	5-15 5-22
	Preparing and Positioning Honeycomb.....	5-16 5-23
	Installing Lifting Slings.....	5-17 5-24
	Positioning and Lashing Drums to Cargo Tie-down Rings.....	5-18 5-24

	<i>Paragraph</i>	<i>Page</i>
Lashing Drums to the Platform.....	5-19	5-27
Installing Attitude Control Bar.....	5-20	5-33
Installing Extraction System.....	5-21	5-36
Placing Extraction Parachutes.....	5-22	5-39
Marking Rigged Load.....	5-23	5-39
Equipment Required.....	5-24	5-39
Section III RIGGING FOUR DRUMS ON A 20-FOOT PLATFORM		
Description of Load.....	5-25	5-41
Preparing Platform.....	5-26	5-41
Positioning and Lashing Drums on the Platform.....	5-27	5-43
Installing Attitude Control Bar.....	5-28	5-59
Installing Extraction System.....	5-29	5-62
Placing Extraction Parachutes.....	5-30	5-64
Marking Rigged Load.....	5-31	5-64
Equipment Required.....	5-32	5-65
Section IV RIGGING FIVE DRUMS ON A 24-FOOT PLATFORM		
Description of Load.....	5-33	5-66
Preparing Platform.....	5-34	5-66
Positioning and Lashing Drums on the Platform.....	5-35	5-68
Installing Attitude Control Bar.....	5-36	5-89
Installing Extraction System.....	5-37	5-92
Placing Extraction Parachutes.....	5-38	5-94
Marking Rigged Load.....	5-39	5-94
Equipment Required.....	5-40	5-95
APPENDIX A Deleted in Change 4		
APPENDIX B EQUIPMENT REQUIRED.....	B-1	
GLOSSARY.....	Glossary-1	
REFERENCES.....	References-1	

PREFACE

SCOPE

This manual tells and shows how to rig 500-gallon-capacity collapsible fabric drums (model 5-14-191-1) with or without a 50-gallon-per-minute pumping assembly or a liquid fuel filter/ separator (filter) for low-velocity airdrop on type II and type V platforms. Fuel drums are low-velocity airdropped from C-130, C-141, C-5, and C-17 aircraft. This manual also tells and shows how to rig fuel drums for LAPE airdrop on metric and type V platforms from C-130 aircraft.

USER INFORMATION

The proponent of this publication is HQ TRADOC. You are encouraged to report any errors or omissions and to suggest ways of making this a better manual.

Army personnel, send your comments on DA Form 2028 directly to:

Director
Aerial Delivery and Field Services Department
USA Quartermaster Center and School
1010 Shop Road
Fort Lee, Virginia 23801-1502

Air Force personnel, send your reports on AFTO Form 22 through:

Headquarters
Air Mobility Command (AMC/DOKT)
402 Scott Drive, Unit 3AI
Scott AFB, Illinois 62225-5302

Air Force personnel in Special Operations Command, send your reports on AFTO Form 22 through:

HQ AFSOC/DOXT
100 Bartley Street, Suite 260
Hurlburt Field, FL 32544-5273

to:

Director
Aerial Delivery and Field Services Department
USA Quartermaster Center and School
1010 Shop Road
Fort Lee, Virginia 23801-1502

Also send an information copy of AFTO Form 22 to:

SA-ALC/TILD
485 Quentin Roosevelt Road
Kelly AFB, Texas 78241-5000

CHAPTER 1

INTRODUCTION

1-1. Description of Items

The 500-gallon-capacity collapsible fabric fuel drums can be dropped with or without the 50-gallon-per-minute pumping assembly or liquid fuel filter/separator (filter) in the following configurations:

a. One or two drums with a pumping assembly on a type II airdrop platform for low-velocity airdrop from a C-130 or C-141 aircraft.

b. Two or three drums without a pumping assembly on a type II airdrop platform for low-velocity airdrop from C-130 and C-141 aircraft. Two to seven drums without a pumping assembly are rigged on a type V airdrop platform for low-velocity airdrop from C-130, C-141, C-5, and C-17 aircraft.

c. Three, six, or seven drums with a pumping assembly on a type V airdrop platform for low-velocity airdrop from C-130, C-141, C-5, and C-17 aircraft.

d. Two to five drums with or without a pumping assembly or a liquid fuel separator (filter) on a LAPES airdrop platform for LAPE airdrop from a C-130 aircraft.

e. Two to five drums without a pumping assembly on a type V airdrop platform for LAPE airdrop from a C-130 aircraft.

1-2. Special Considerations

CAUTION

There must be no more than 432 gallons of liquid in each drum when the drum is rigged for low-velocity and LAPE airdrops.

a. These loads may contain hazardous materials- gasoline, JP-4 fuel, or diesel fuel. Hazardous materials in these loads must be packaged, marked, and labeled in compliance with AFJMAN 24-204/TM 38-250.

b. Gasoline, JP-4 fuel, or diesel fuel may be airdropped using these procedures. Each drum must be weighed to learn its exact weight. For computing liquid weight per US gallon, use 6 pounds for gasoline, 6.6 pounds for JP-4 fuel, and 6.68 pounds for diesel fuel.

c. The drum is flexible, and will rebound on impact. The lashings may break and cause the drum to roll off the platform and create a possible hazard in the area.

d. A copy of this manual must be available to the joint airdrop inspectors during the before- and after- loading inspections.

WARNING

Do not add air to drums. Changes in pressurization can cause leaking or bursting. Failure to comply endangers mission, aircraft,

CHAPTER 4

RIGGING DRUMS FOR LOW-VELOCITY AIRDROP ON A TYPE V PLATFORM

Section I

RIGGING TWO DRUMS WITHOUT PUMPING ASSEMBLY ON AN 8-FOOT PLATFORM

4-1. Description of Load

Two drums are rigged on an 8-foot, type V platform with two G-11A or G-11B cargo parachutes. Filled with 432 gallons of gasoline, each drum weighs 2,842 pounds and is 62 inches long and 53 inches in diameter. Each drum weighs 250 pounds when empty.

Note: If the drums are filled with a fuel other than gasoline, the weight must be computed.

4-2. Preparing Platform

Prepare an 8-foot, type V airdrop platform using four tandem links and 16 clevises as shown in Figure 4-1.

- Notes:**
1. The nose bumper may or may not be installed.
 2. Measurements given in this section are from the front edge of the platform, NOT from the front edge of the nose bumper.

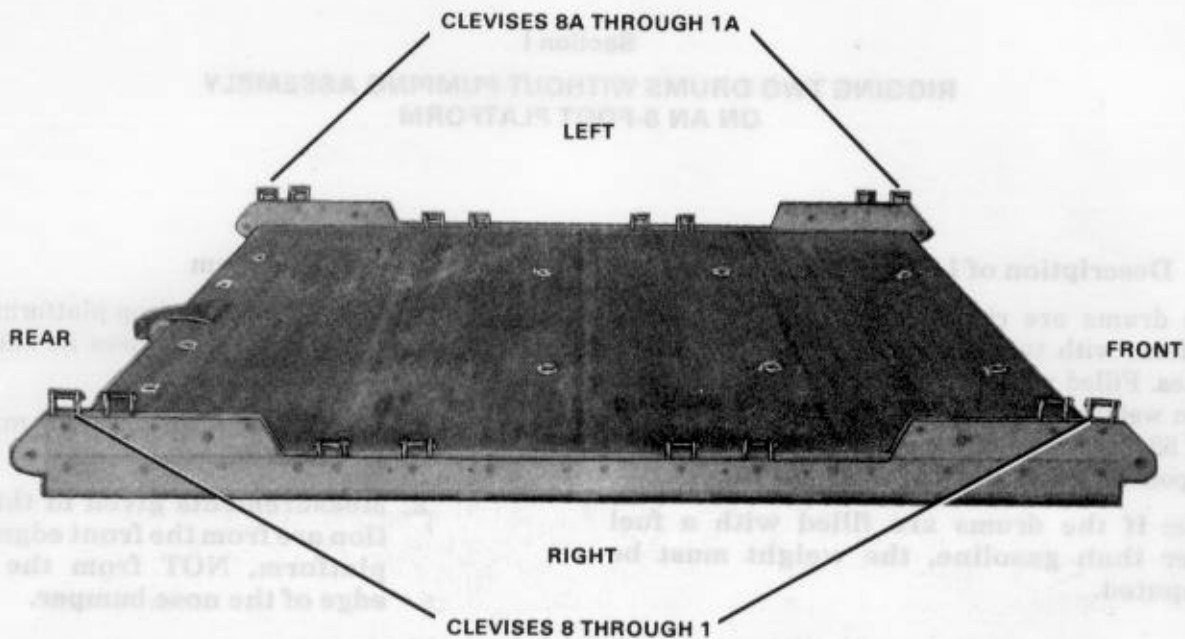

Step:

1. Inspect, or assemble and inspect, the platform as outlined in TM 10-1670-268-20&P/ TO 13C7-52-22.
2. Install a tandem link on the front of each platform side rail using holes 1, 2, and 3. Install a tandem link on the rear of each platform side rail using holes 14, 15, and 16.
3. Install a clevis on bushings 1 and 2 of each front tandem link and on bushings 3 and 4 of each rear tandem link.
4. Starting at the front of the platform, install clevises on each platform side rail using the bushings bolted on holes 6, 7, 11, and 12.
5. Starting at the front of the platform, number the clevises bolted to the right side 1 through 8 and those bolted to the left side 1A through 8A.

Figure 4-1. Platform prepared

4-3. Preparing and Positioning Honeycomb Stacks

Prepare and position the honeycomb stacks as shown in Figure 4-2.

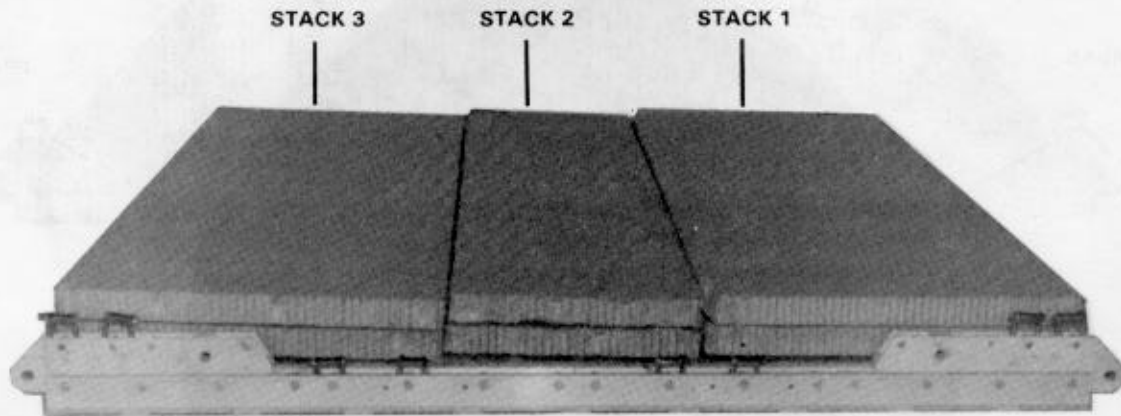

Stack Number	Pieces	Width (Inches)	Length (Inches)	Material	Instructions
1	2	96	36	Honeycomb	Place stack even with front edge of platform.
2	2	96	24	Honeycomb	Place stack flush against stack 1.
3	2	96	36	Honeycomb	Place stack flush against stack 2.

Figure 4-2. Honeycomb stacks positioned

4-4. Installing Lifting Slings

Install the lifting slings to each fuel drum using four load tiedown clevises and two 12-foot (2-loop), type XXVI nylon webbing slings as shown in Figure 4-3.

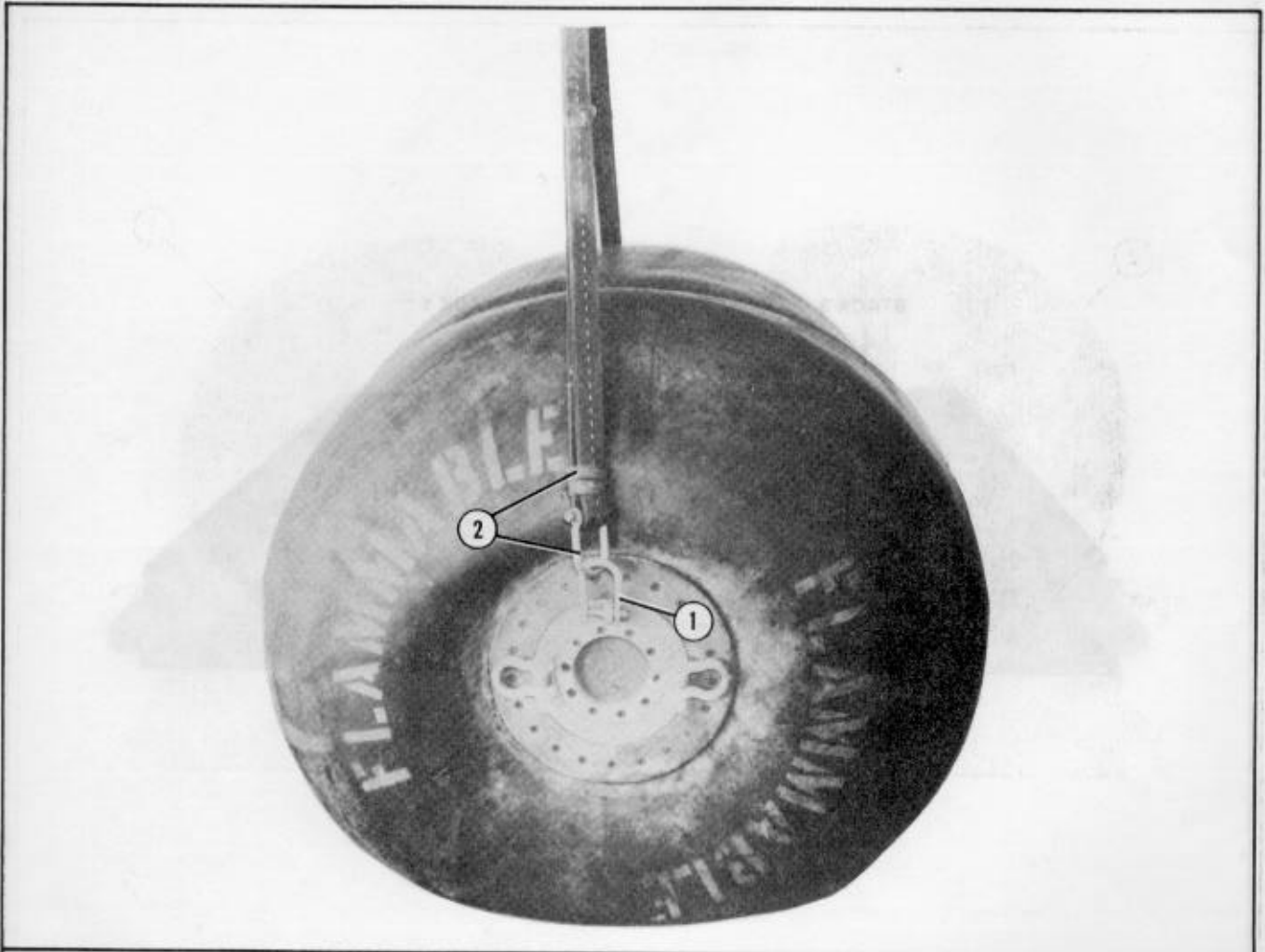

Notes: 1. Remove tiedown clevises when not used for lashing purposes.
2. Make sure the drums and drum fittings are not leaking and that two D-ring clevises are on the swivel plate.

- ① Bolt a load tiedown clevis to the center shackle of the swivel plate.
- ② Route a load tiedown clevis through the clevis bolted to the shackle. Bolt the clevis to a 12-foot sling.
- ③ Repeat the above procedure on the opposite side of the fuel drum and to the remaining fuel drums (not shown).

Figure 4-3. Lifting slings installed

4-5. Positioning and Lashing Drums

Position and lash the fuel drums as described below.

a. *Positioning Drums.* Position the fuel drums on the platform as shown in Figure 4-4.

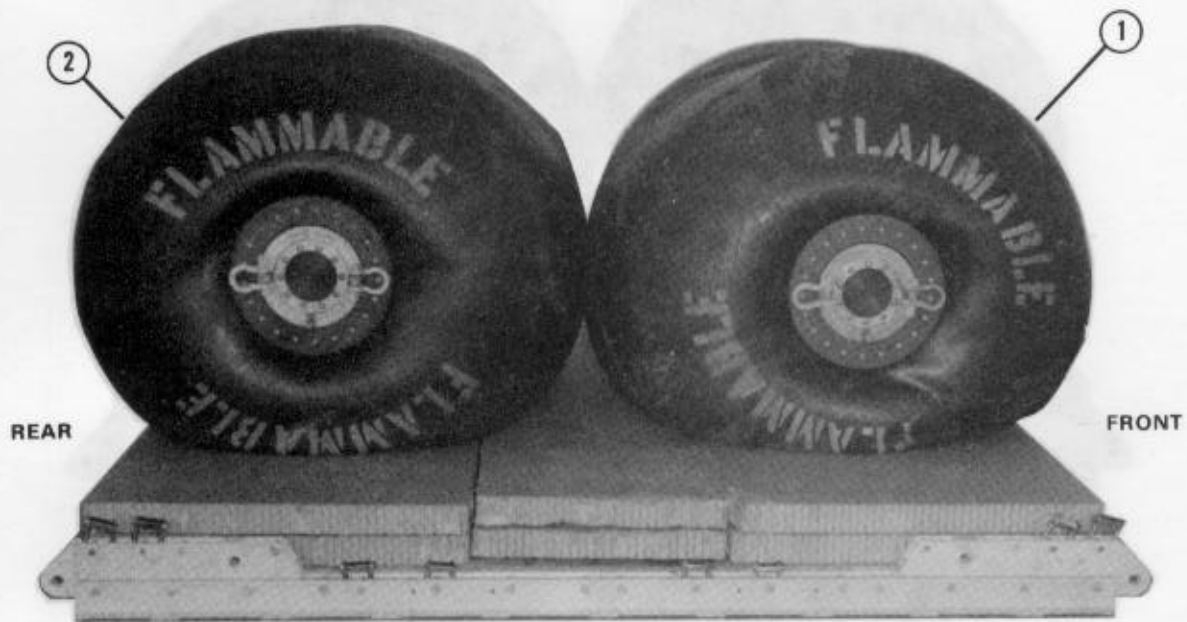

- ① Center the front fuel drum with its rear edge 48 inches from the front edge of the honeycomb.
- ② Center the rear fuel drum with its front edge flush against the front fuel drum.
- ③ Remove the lifting slings (not shown).
- ④ Install the dust caps, if available (not shown).

Note: Make sure the shackles on the drums are parallel to the platform before installing the lashings.

Figure 4-4. Fuel drums positioned

b. *Lashing Drums.* Use eighteen 15-foot tiedown assemblies to lash the fuel drums to the platform as shown in Figure 4-5 and according to FM 10-500/TO 13C7-1-5.

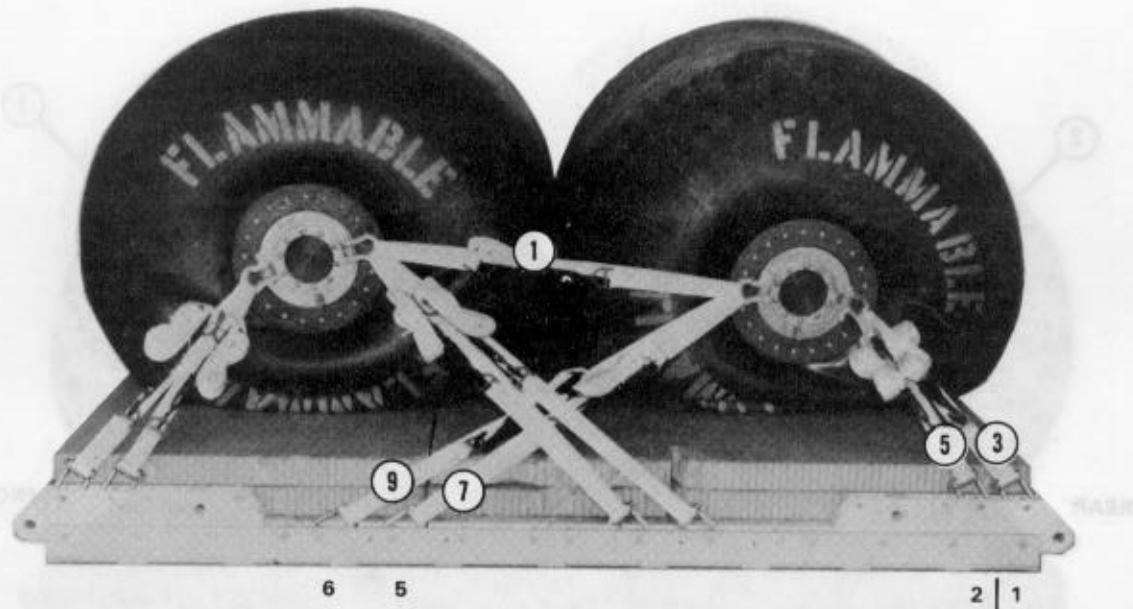

Lashing Number	Tiedown Clevis Number	Instructions
1	—	Pass lashing: Through the right rear shackle of the front drum and through the right front shackle of the rear drum.
2	—	Through the left rear shackle of the front drum and through the left front shackle of the rear drum.
3	1	Through the right front shackle of the front drum.
4	1A	Through the left front shackle of the front drum.
5	2	Through the right front shackle of the front drum.
6	2A	Through the left front shackle of the front drum.
7	5	Through the right rear shackle of the front drum.
8	5A	Through the left rear shackle of the front drum.
9	6	Through the right rear shackle of the front drum.
10	6A	Through the left rear shackle of the front drum.

Figure 4-5. Fuel drums lashed to platform

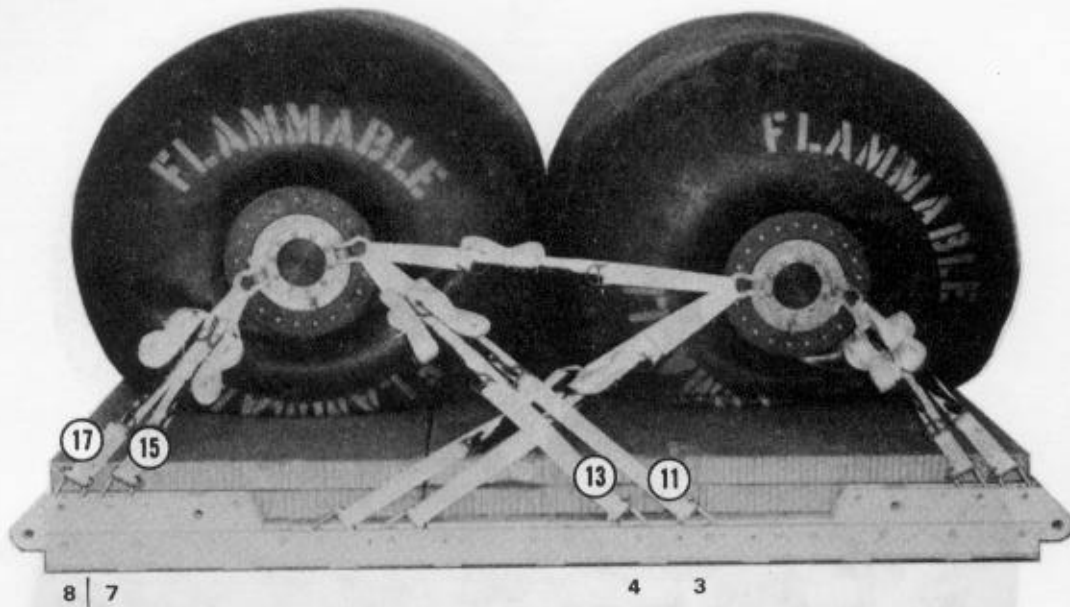

Lashing Number	Tiedown Clevis Number	Instructions
11	3	Pass lashing:
12	3A	Through the right front shackle of the rear drum.
13	4	Through the left front shackle of the rear drum.
14	4A	Through the right front shackle of the rear drum.
15	4A	Through the left front shackle of the rear drum.
16	7	Through the right rear shackle of the rear drum.
17	7A	Through the left rear shackle of the rear drum.
18	8	Through the right rear shackle of the rear drum.
	8A	Through the left rear shackle of the rear drum.

Figure 4-5. Fuel drums lashed to platform (continued)

4-6. Installing and Safetying Suspension Slings

Install and safety four 9-foot (3-loop), type X nylon webbing slings or four 9-foot (2-loop), type XXVI nylon webbing slings to the tandem links as shown in Figure 4-6.

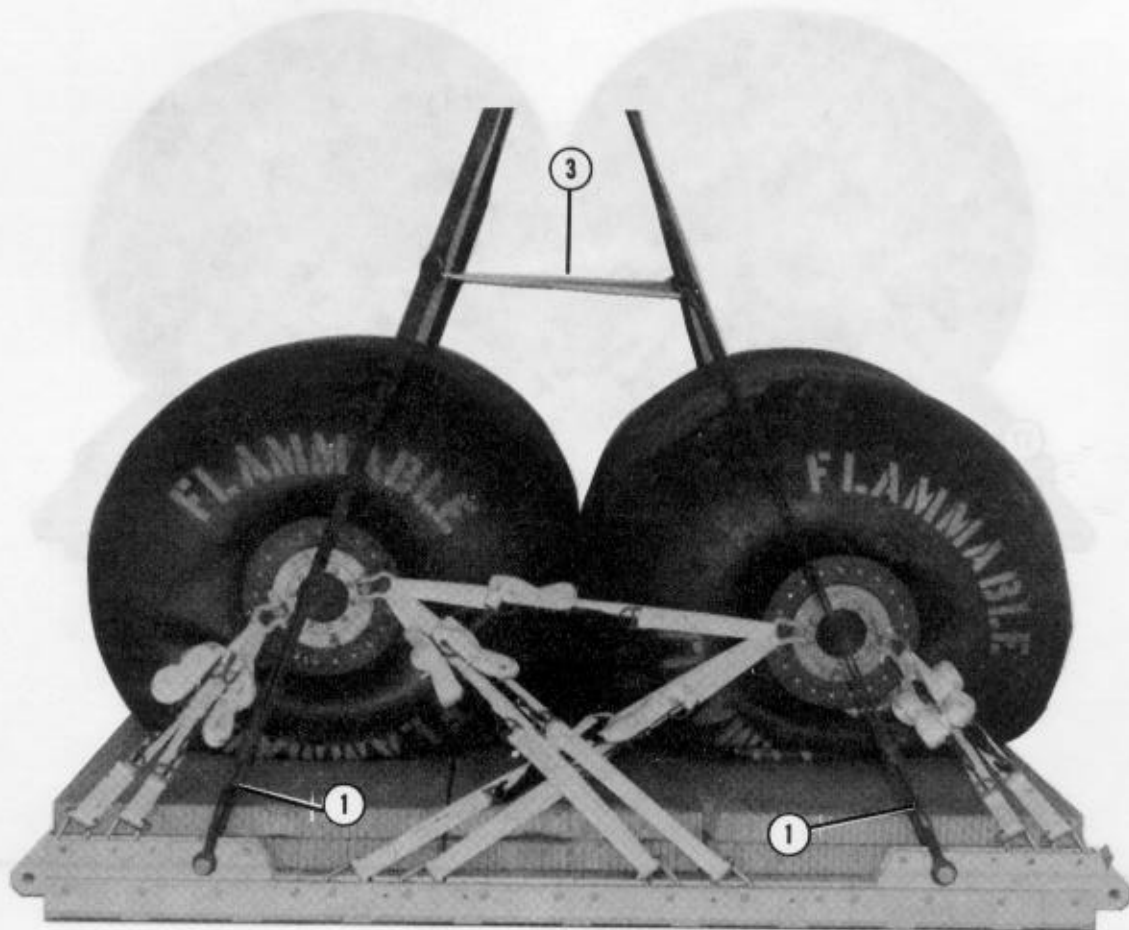

- ① Bolt a 9-foot sling to each tandem link using a large suspension clevis. Make sure the keepers are pushed down to fit snug against the clevis. Tape them in place.
- ② Raise the suspension slings to their full extent with a lifting provision (not shown).
- ③ Safety the slings with a deadman's tie according to FM 10-500/TO 13C7-1-5.

Figure 4-6. Suspension slings installed and safetyed

4-7. Installing Cargo Parachutes

Install two G-11A or G-11B cargo parachutes as shown in Figure 4-7 and as outlined in FM 10-500/TO 13C7-1-5.



5

- ① Position the two cargo parachutes on top of the rear drum. Install the parachute restraint strap as outlined in FM 10-500/TO 13C7-1-5 using clevises 5 and 5A.
- ② Install the parachute release knives as outlined in FM 10-500/TO 13C7-1-5.

Figure 4-7. Cargo parachutes stowed and restrained

4-8. Installing Extraction System

Install the EFTC extraction system according to FM 10-500/TO 13C7-1-5 and as shown in Figure 4-8.

Note: The SL/CS must not be used with the 8-foot, type V platform.

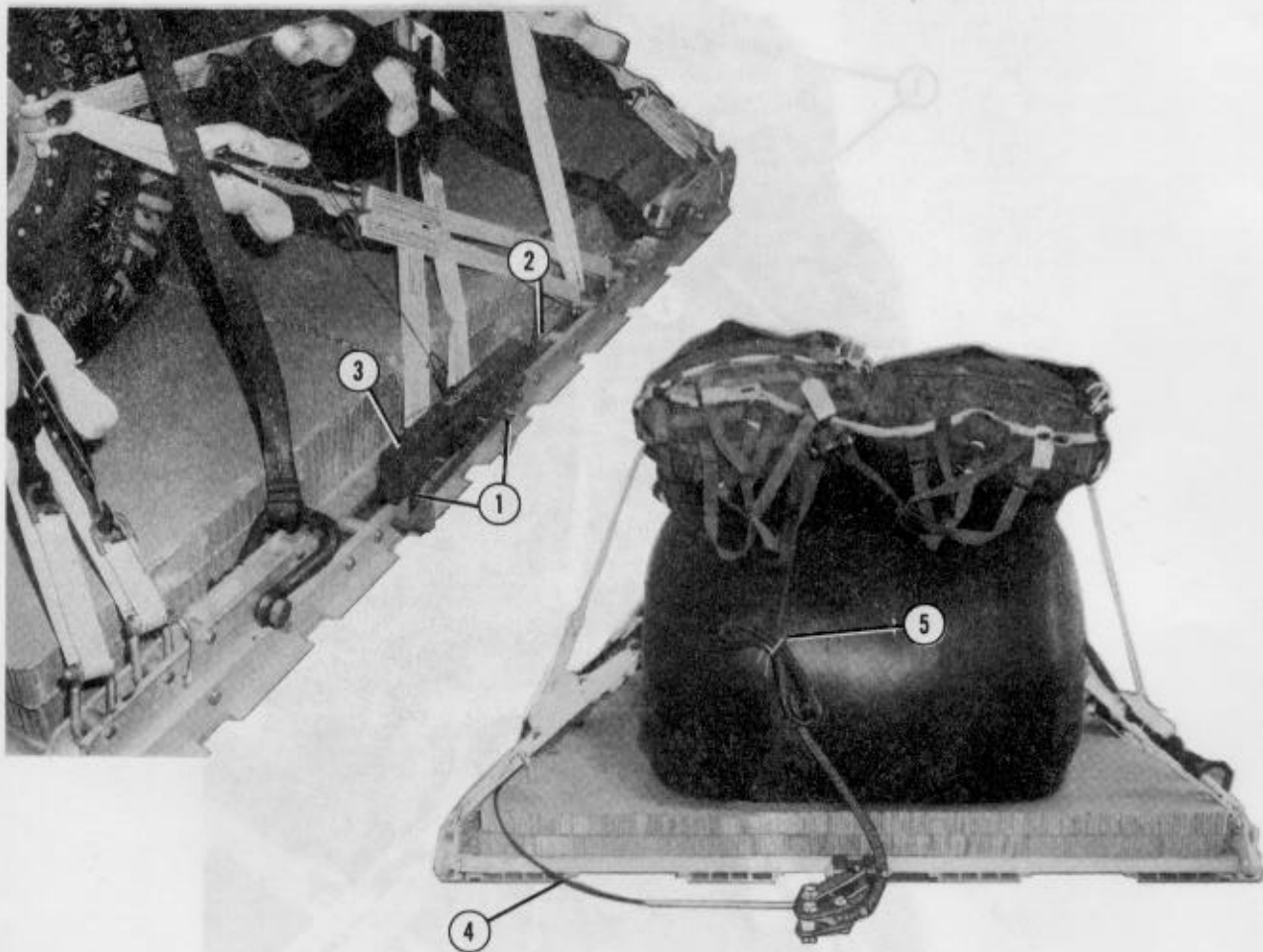

- ① Install the actuator mounting brackets to the front EFTC mounting holes on the left platform side rail.
- ② Install a 12-foot cable to the actuator assembly.
- ③ Bolt the actuator assembly to the mounting brackets.
- ④ Route the cable on top of the honeycomb. Secure it to the inside of the lashings with 1/4-inch cotton webbing.
- ⑤ Use a 9-foot (2-loop), type XXVI nylon webbing sling for the deployment line. S-fold the excess line, and tie it with type I, 1/4-inch cotton webbing.

Figure 4-8. EFTC installed

4-9. Installing Parachute Release

Prepare and attach an M-1 cargo parachute release according to FM 10-500/TO 13C7-1-5 and as shown in Figure 4-9.

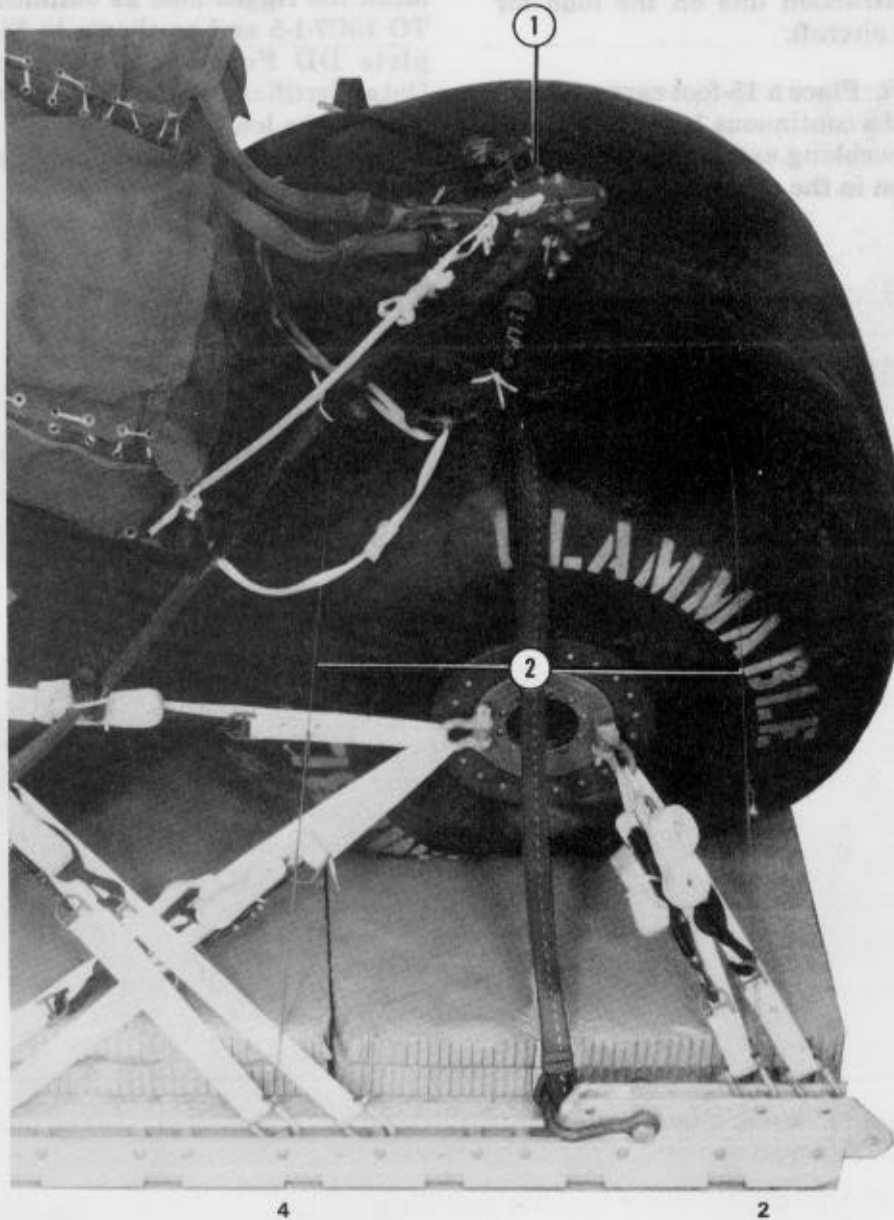

- ① Attach the M-1 release to the suspension slings as outlined in FM 10-500/TO 13C7-1-5. Place a 12- by 12-inch piece of felt or honeycomb under the M-1 release. Place and center the release on top of the front fuel drum.
- ② Secure the M-1 release to clevises 2 and 2A and 4 and 4A with lengths of type III nylon cord according to FM 10-500/TO 13C7-1-5.

Figure 4-9. Parachute release installed

4-10. Placing Extraction Parachute

Place the extraction parachute as described below.

a. C-130 Aircraft. Place a 15-foot cargo extraction parachute and a 60-foot (1-loop), type XXVI nylon webbing extraction line on the load for installation in the aircraft.

b. C-141 Aircraft. Place a 15-foot cargo extraction parachute and a continuous 160-foot (1-loop), type XXVI nylon webbing extraction line on the load for installation in the aircraft.

4-11. Installing Provisions for Emergency Restraint

Install a medium clevis to each front tandem link as shown in Figure 4-10.

4-12. Marking Rigged Load

Mark the rigged load as outlined in FM 10-500/TO 13C7-1-5 and as shown in Figure 4-10. Complete DD Form 1387-2 (Special Handling Data/Certification), and securely attach it to the load. If the load varies from the one shown, the weight, height, CB, and parachute requirements must be recomputed.

CAUTION

Make the final rigger inspection required by FM 10-500/TO 13C7-1-5 before the load leaves the rigging site.

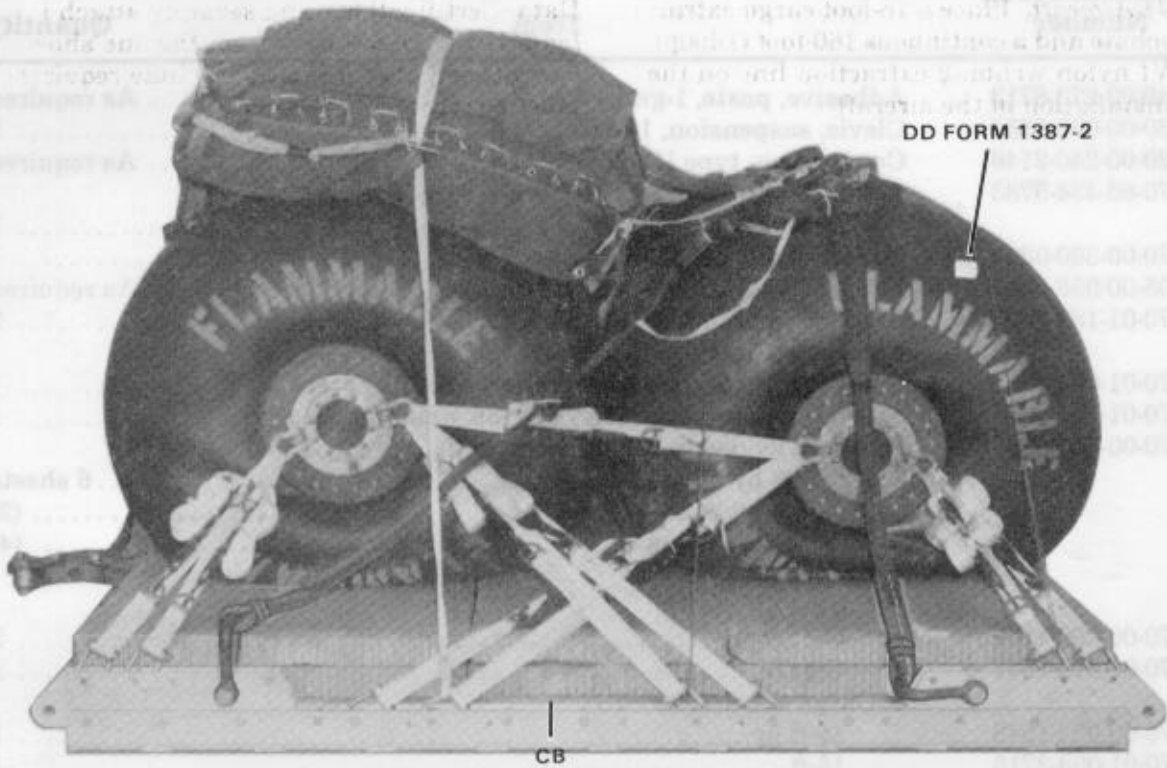

RIGGED LOAD DATA

Weight: Load shown	*7,320 pounds
Maximum load allowed	8,000 pounds
Height	70 inches
Width	108 inches
Length	124 inches
Overhang: Front	4 inches
Rear	24 inches
CB (from front edge of platform)	54 inches
Extraction System	EFTC

*Includes 432 gallons of gasoline in each drum.

Figure 4-10. Two drums without pumping assembly rigged on an 8-foot, type V airdrop platform for low-velocity airdrop

4-13. Equipment Required

Use the equipment listed in Table 4-1 to rig this load.

Table 4-1. Equipment required for rigging two drums without pumping assembly on an 8-foot, type V airdrop platform for low-velocity airdrop

National Stock Number	Item	Quantity
8040-00-273-8713	Adhesive, paste, 1-gal	As required
4030-00-090-5354	Clevis, suspension, 1-in (large)	5
4020-00-240-2146	Cord, nylon, type III, 550-lb	As required
1670-00-434-5783	Coupling, airdrop, extraction force transfer w cable, 12-ft	1
1670-00-360-0328	Cover, clevis, large	1
8305-00-958-3685	Felt, 1/2-in thick	As required
1670-01-183-2678	Leaf, extraction line	2
	Line, extraction:	
1670-01-064-4452	60-ft (1-loop), type XXVI nylon webbing	1
1670-01-107-7652	160-ft (1-loop), type XXVI nylon webbing	1
1670-00-753-3928	Pad, energy-dissipating, honeycomb, 3- by 36- by 96-in:	6 sheets
	96- by 24-in	(2)
	96- by 36-in	(4)
	Parachute:	
	Cargo:	
1670-00-269-1107	G-11A <u>or</u>	2
1670-01-016-7841	G-11B	2
	Cargo extraction:	
1670-00-052-1548	15-ft <u>or</u>	1
1670-01-063-3715	15-ft	1
	Platform, AD, type V, 8-ft:	1
	Bracket:	
1670-01-162-2375	Inside EFTA	(1)
1670-01-162-2374	Outside EFTA	(1)
1670-01-162-2372	Clevis, load tiedown	(20)
1670-01-162-2376	Extraction bracket assembly	(1)
1670-01-162-2381	Tandem link	(4)
1670-01-097-8816	Release, cargo parachute, M-1	1
	Sling, cargo airdrop:	
	For lifting:	
1670-00-062-6303	12-ft (2-loop), type XXVI nylon webbing	2
	For riser extension:	
1670-00-823-5043	20-ft (3-loop), type X nylon webbing <u>or</u>	2
1670-01-062-6302	20-ft (2-loop), type XXVI nylon webbing	2
	For suspension or deployment:	
1670-00-753-3631	9-ft (3-loop), type X nylon webbing <u>or</u>	5
1670-01-062-6304	9-ft (2-loop), type XXVI nylon webbing	5
1670-00-040-8219	Strap, parachute release w fastener and release knife	2

Table 4-1. Equipment required for rigging two drums without pumping assembly on an 8-foot, type V airdrop platform for low-velocity airdrop (continued)

National Stock Number	Item	Quantity
7510-00-266-5016	Tape, adhesive, 2-in.....	As required
1670-00-937-0271	Tiedown assembly, 15-ft.....	18
	Webbing:	
8305-00-268-2411	Cotton, 1/4-in, type I.....	As required
	Nylon:	
8305-00-082-5752	Tubular, 1/2-in, 1,000-lb, natural.....	As required
8305-00-263-3591	Type VIII, 3,600-lb.....	As required

Section II

**RIGGING THREE DRUMS WITHOUT PUMPING ASSEMBLY
ON A 12-FOOT PLATFORM**

4-14. Description of Load

Three drums are rigged on a 12-foot, type V platform. Filled with 432 gallons of gasoline, each drum weighs 2,842 pounds and is 62 inches long and 53 inches in diameter. An empty drum weighs 250 pounds.

Note: Fill drums with no more than 432 gallons of fuel. If the drums are filled with a fuel other than gasoline, the drum weight must be computed.

4-15. Preparing Platform

Prepare a 12-foot, type V airdrop platform using four tandem links and 20 clevises as shown in Figure 4-11.

**Notes: 1. The nose bumper may or may not be installed.
2. Measurements given in this section are from the front edge of the platform, NOT from the front edge of the nose bumper.**

WARNING

Do not add air to drums. Pressurization changes will cause leaking or bursting.

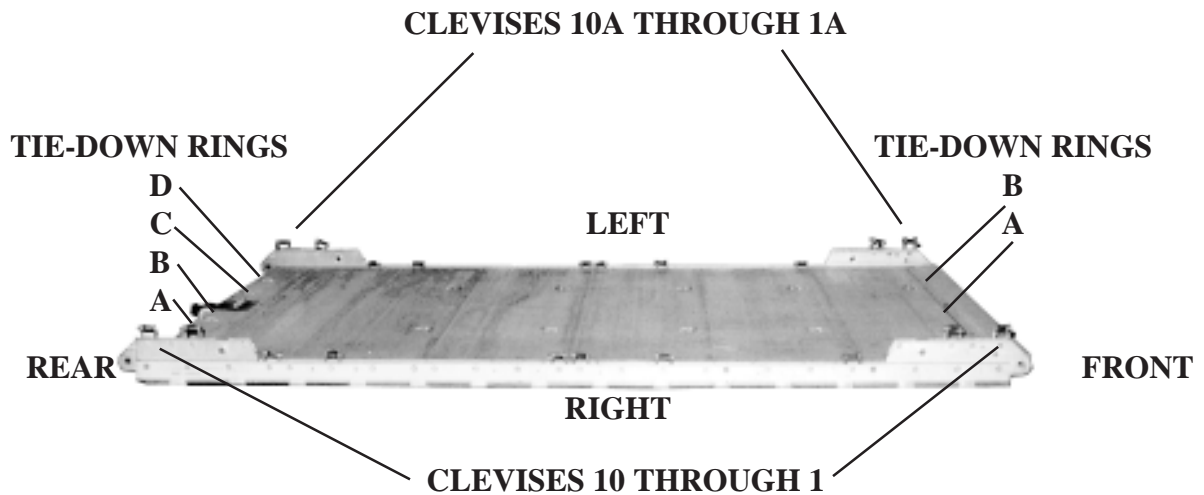

Step:

1. Inspect, or assemble and inspect, the platform as outlined in TM 10-1670-268-20&P/TO 13C7-52-22.
2. Install a tandem link on the front of each platform side rail using holes 1, 2, and 3. Install a tandem link on the rear of each platform side rail using holes 22, 23, and 24.
3. Bolt a clevis on bushings 1 and 3 of each front tandem link, and on bushings 2 and 4 of each rear tandem link.
4. Starting at the front of the platform, install clevises on each platform side rail using the bushings bolted on holes 5, 10, 12, 13, 19 and 21.
5. Starting at the front of the platform, number the clevises bolted to the right side 1 through 10, and those bolted to the left side 1A through 10A.
6. Label the tiedown rings according to FM 10-500-2/TO 13C7-1-5.

Figure 4-11. Platform prepared

4-16. Preparing and Positioning Honeycomb Stacks

Prepare and position the honeycomb stacks as shown in Figure 4-12.

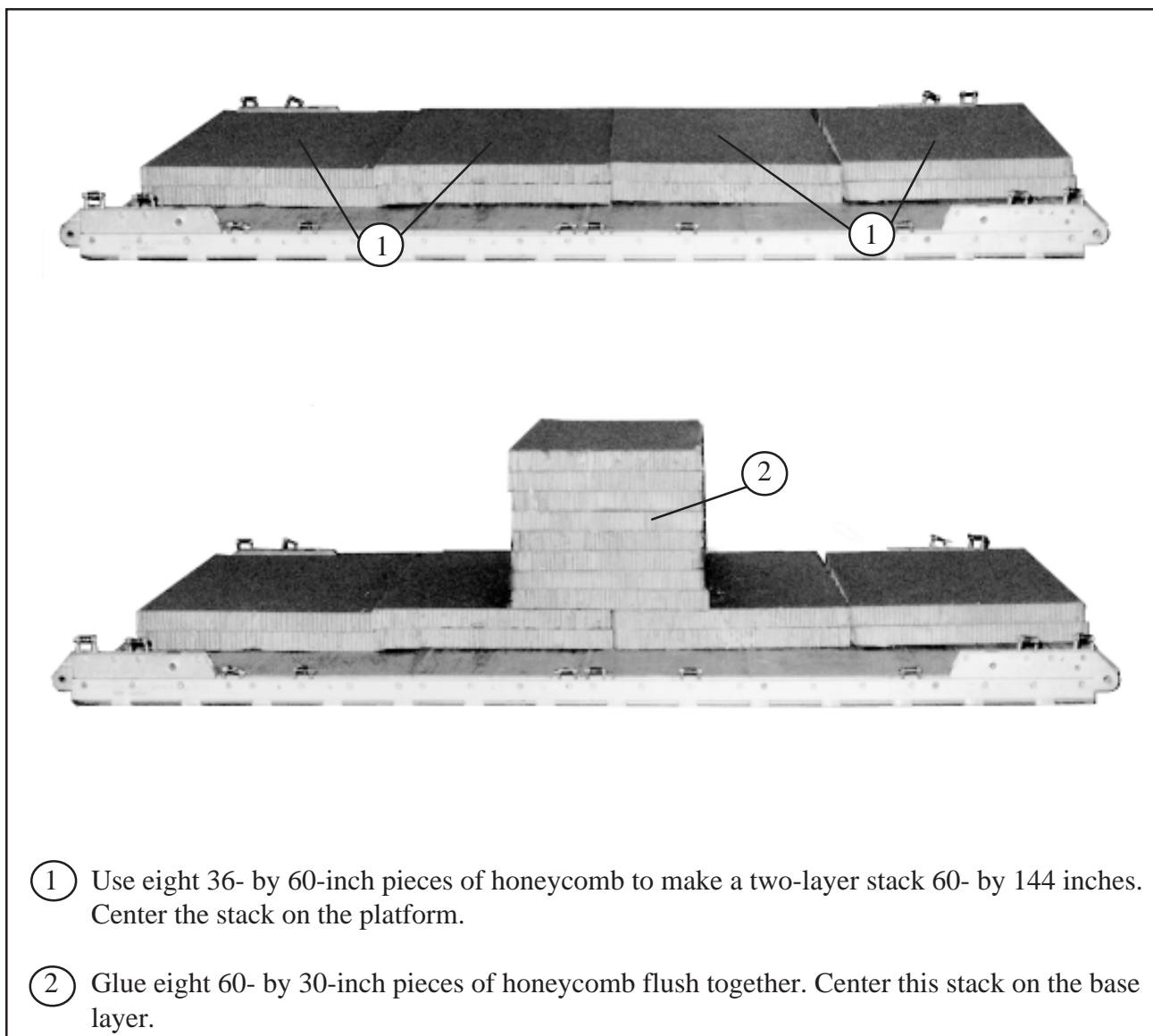
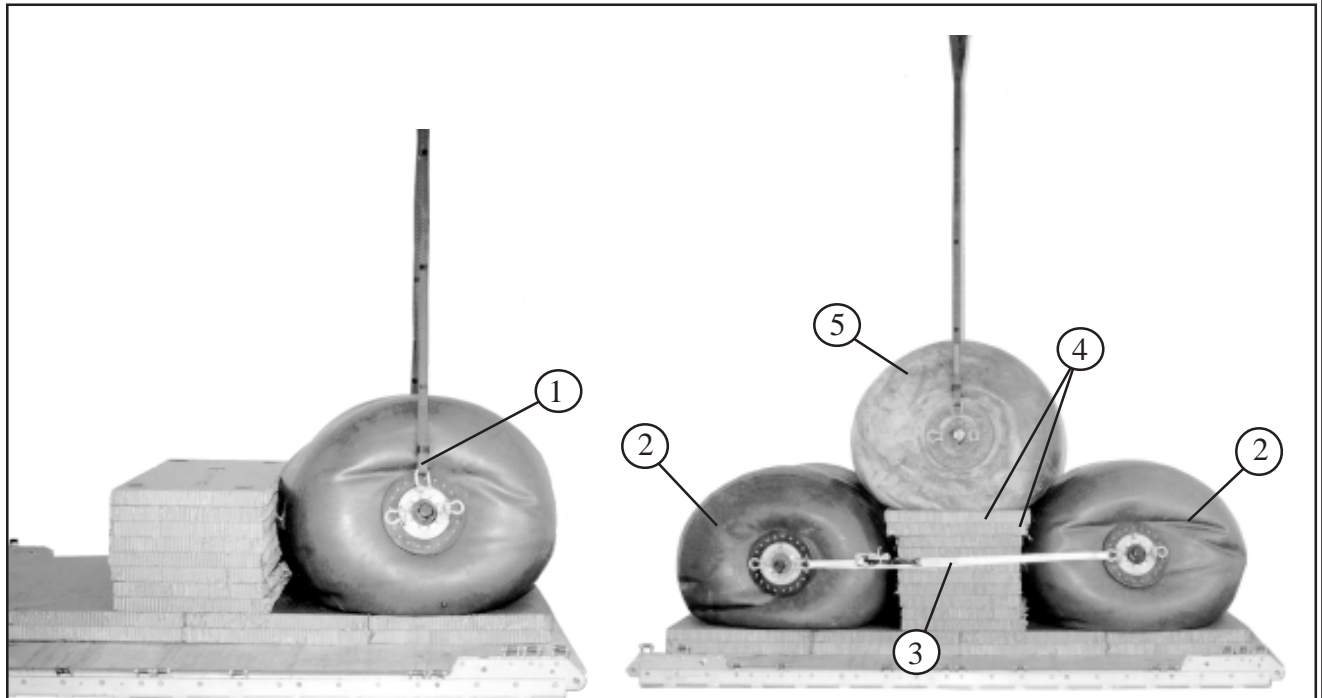

Figure 4-12. Honeycomb stacks positioned

4-17. Installing Lifting Slings and Positioning Drums

Lift the drums and position them on the honeycomb as shown in Figure 4-13.



- ① Attach a 9-foot (2-loop), type XXVI nylon webbing sling to the upper shackle on each side of the drum with a platform clevis.
- ② Lift a drum onto the front and rear of the honeycomb base as shown.
- ③ Lash the inside shackles of the two drums together on each side with a 15-foot tiedown assembly.
- ④ Glue a 60- by 34-inch piece of honeycomb centered on the stack. Glue a 60- by 36-inch piece of honeycomb centered over the piece placed previously.
- ⑤ Lift and position a drum onto the honeycomb stack.

Figure 4-13. Fuel drums positioned

4-18. Lashing Drums

Use twenty 15-foot tie-down assemblies to lash the fuel drums to the platform as shown in Figure 4-14 and according to FM 10-500-2/TO 13C7-1-5.

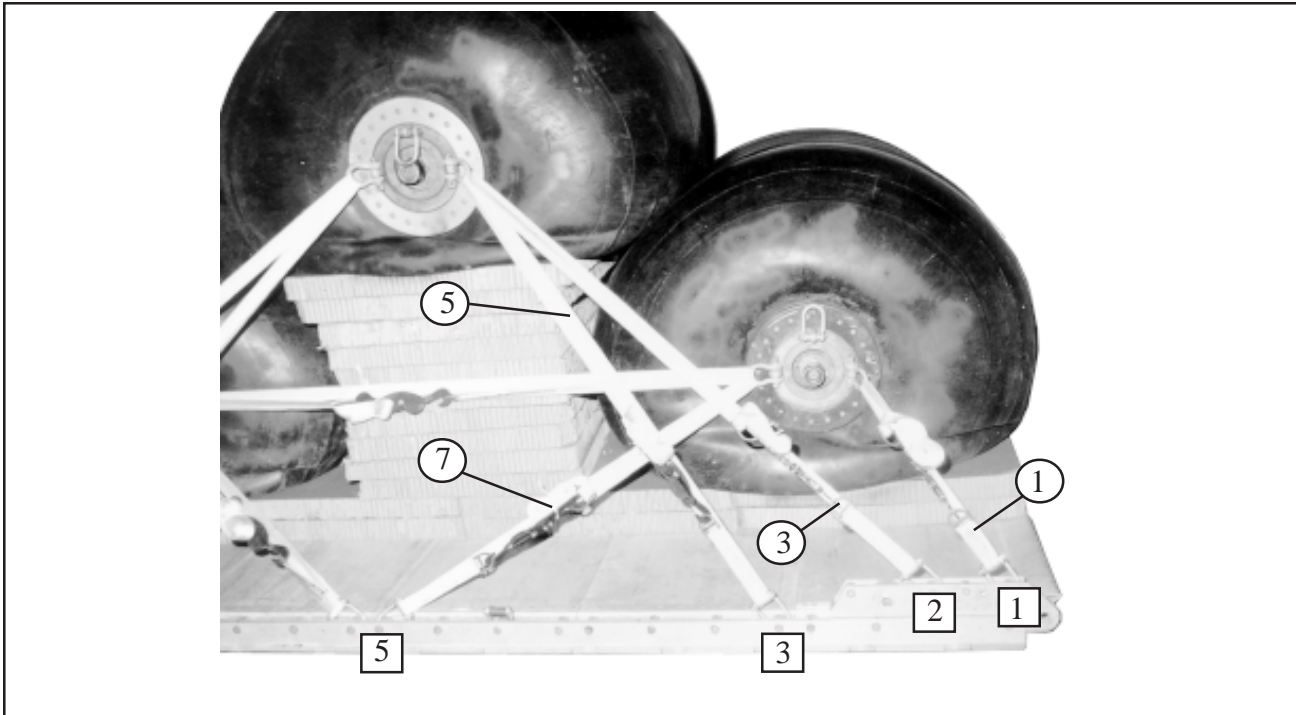

Lashing Number	Tie-down Clevis Number	Instructions
1	1	Pass lashing:
2	1A	Through right front shackle of front drum.
3	2	Through left front shackle of front drum.
4	2A	Through right front shackle of center drum.
5	3	Through left front shackle of center drum.
6	3A	Through right front shackle of center drum.
7	5	Through left front shackle of center drum.
8	5A	Through right rear shackle of front drum.

Figure 4-14. Fuel drums lashed to platform

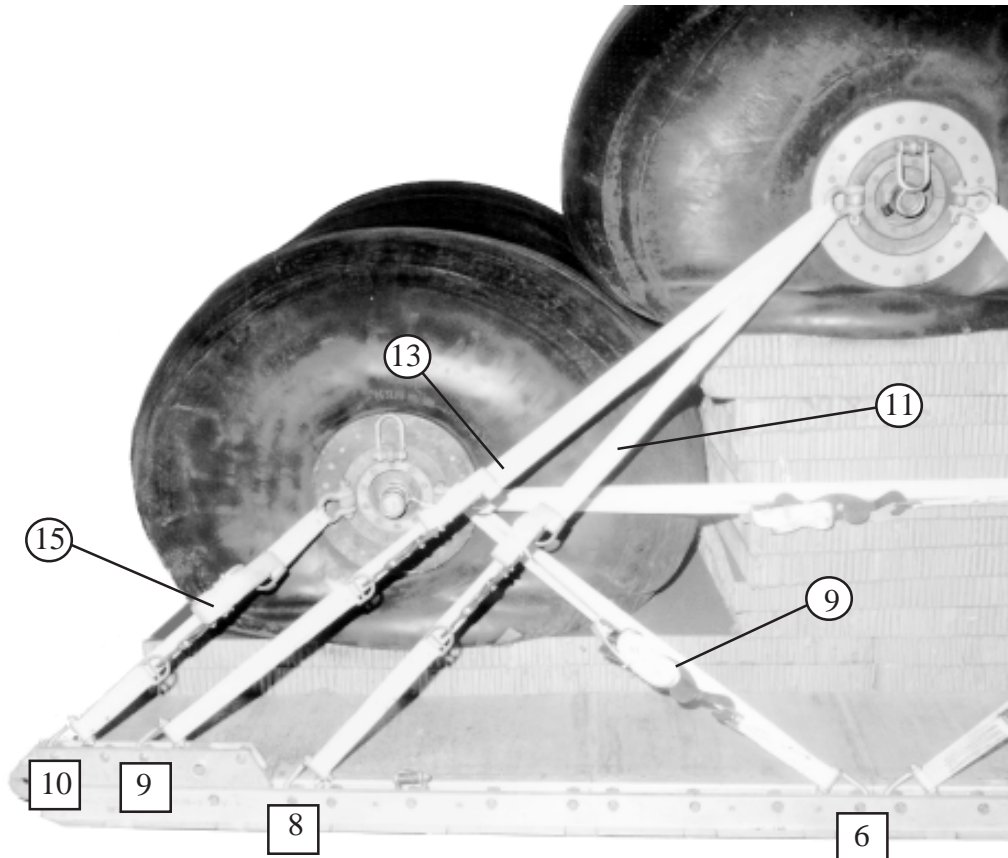

Lashing Number	Tie-down Clevis Number	Instructions
9	6	Pass lashing: Through right front shackle of rear drum.
10	6A	Through left front shackle of rear drum.
11	8	Through right rear shackle of center drum.
12	8A	Through left rear shackle of center drum.
13	9	Through right rear shackle of center drum.
14	9A	Through left rear shackle of center drum.
15	10	Through right rear shackle of rear drum.
16	10A	Through left rear shackle of rear drum.

Figure 4-14. Fuel drums lashed to platform (continued)

4-19. Installing and Safetying Suspension Slings

Install and safety four 12-foot (2-loop), type XXVI nylon webbing slings to the tandem links as shown in Figure 4-15.

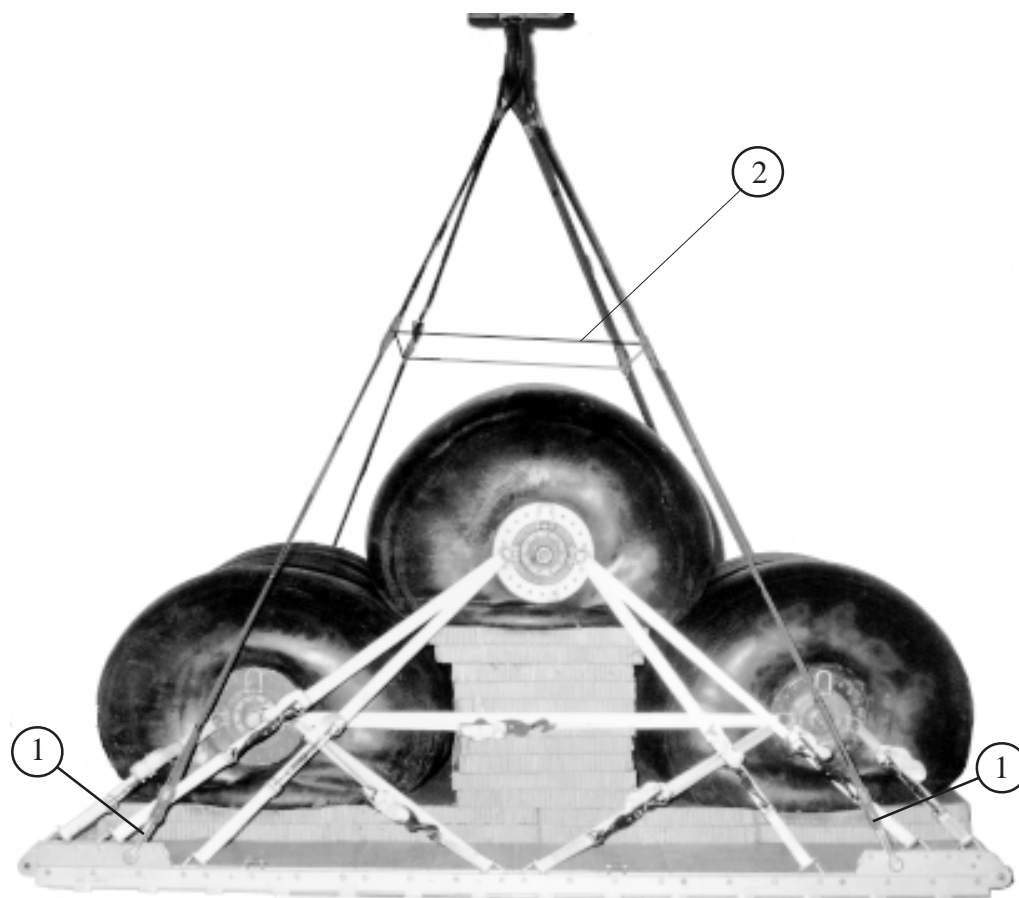

- ① Place the end loop of a 12-foot (2-loop), type XXVI nylon webbing sling in the bell portion of a large clevis. Bolt the clevis to a tandem link. Repeat for the other three tandem links.
- ② Raise the slings and install the deadman's tie according to FM 10-500-2/TO 13C7-1-5.

Figure 4-15. Suspension slings installed and safetied

4-20. Building and Lashing Parachute Stowage Platform

Build the parachute stowage platform and lash it to the load with four 15-foot lashings as shown in Figure 4-16.

Notes: 1. This drawing is not to scale.
2. All dimensions are given in inches.
3. Use eightpenny nails.

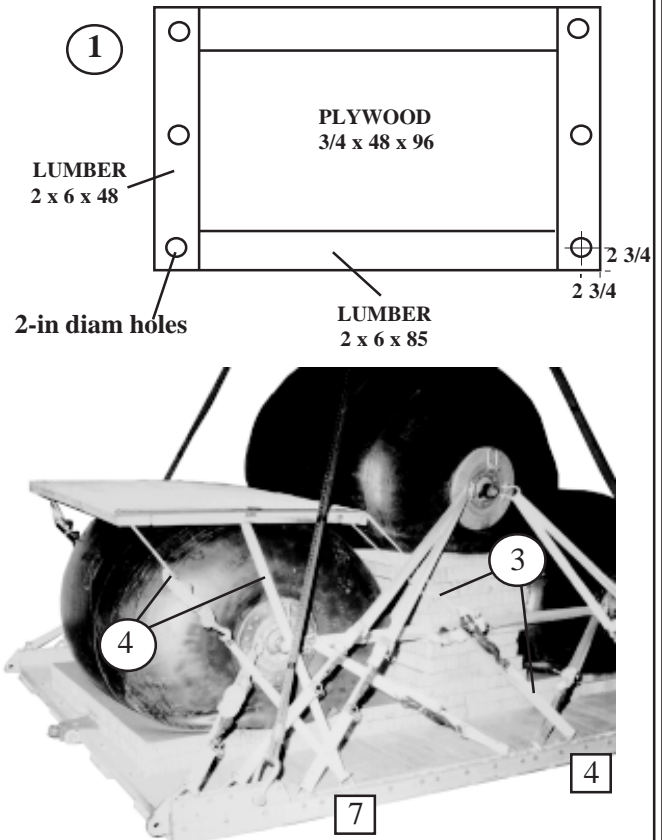
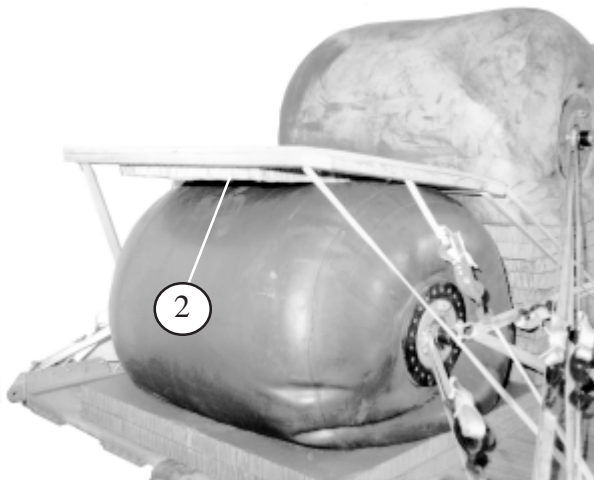

- ① Build the parachute stowage platform as shown. Nail the 2- by 6-inch pieces of lumber to the edges of the plywood and drill 2-inch holes for the lashings.
- ② Center a piece of honeycomb 48 inches wide and 26 inches long over the rear drum.
- ③ Place the parachute stowage platform over the honeycomb and the rear drum. Lash the front holes to clevises 4 and 4A.
- ④ Lash the center and rear holes to clevises 7 and 7A.

Figure 4-16. Parachute stowage platform built and lashed

4-21. Installing Cargo Parachutes

Install three G-11 cargo parachutes as shown in Figure 4-17 and according to FM 10-500-2/TO 13C7-1-5.

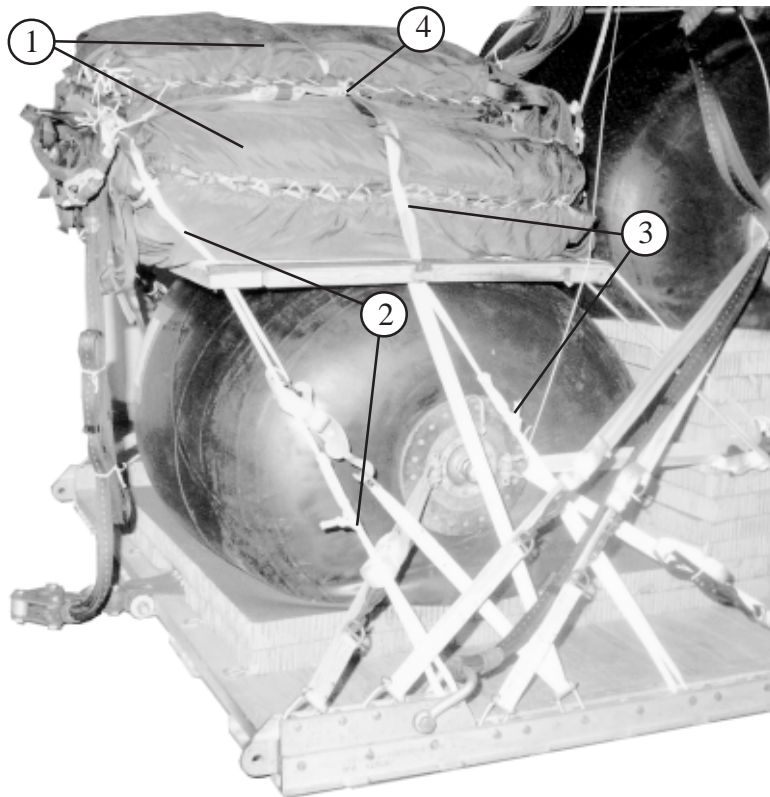

- ① Cluster three G-11 cargo parachutes on the parachute stowage platform.
- ② Pass the rear restraint strap through the rear holes in the parachute stowage platform, and tie the ends to the first bushing on the rear tandem links.
- ③ Pass the front restraint strap through the center holes in the parachute stowage platform, and tie the ends to the 17th bushing on each side of the platform.
- ④ Install the parachute release knives according to FM 10-500-2/TO 13C7-1-5.

Figure 4-17. G-11 cargo parachutes installed

4-22. Installing Parachute Release

Prepare and install an M-1 cargo parachute release as shown in Figure 4-18 and according to FM 10-500-2/TO 13C7-1-5.

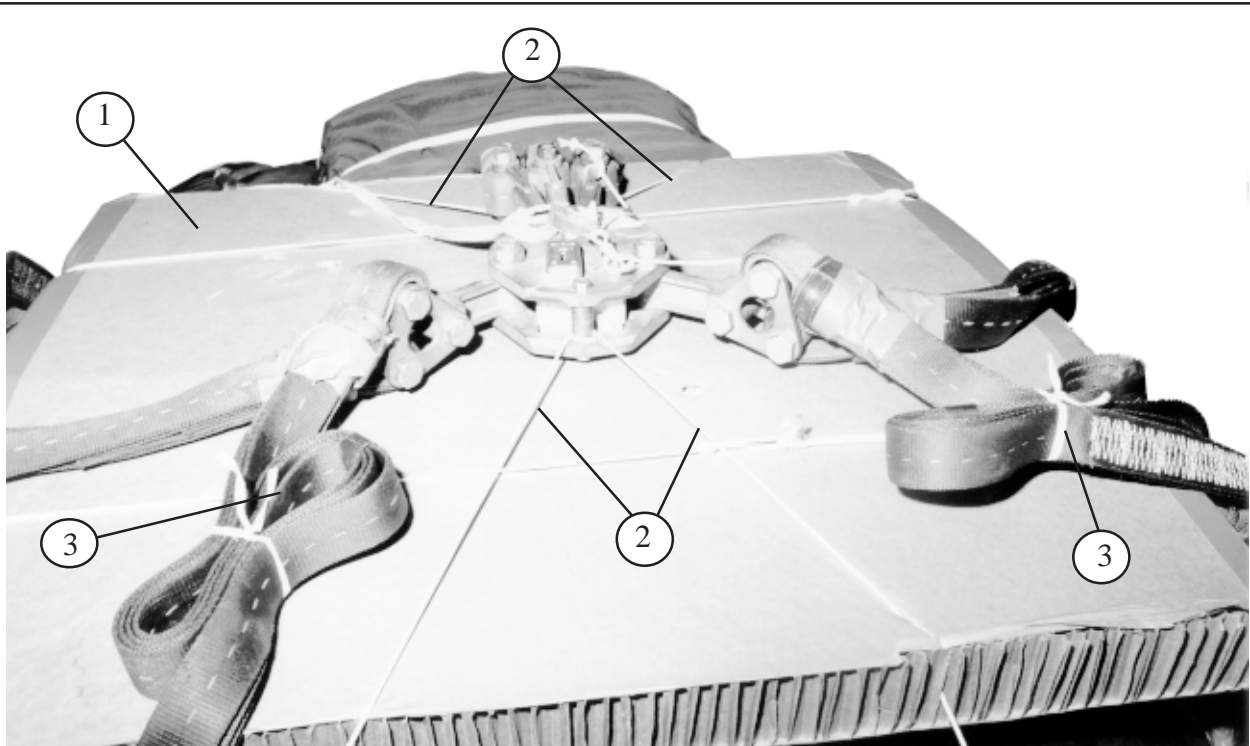

- ① Center a 36 -by 36-inch piece of honeycomb over the upper drum. Secure the honeycomb to the drum shackles with type III nylon cord.
- ② Attach the suspension slings and riser extensions to the M-1 release according to FM 10-500-2/TO 13C7-1-5. Secure the release to the shackles on the lower drums with type III nylon cord.
- ③ S-fold the suspension slings and tie the folds with type I, 1/4-inch cotton webbing.

Figure 4-18. M-1 release installed

4-23. Installing Extraction System

Prepare and install the EFTC extraction system according to FM 10-500-2/TO 13C7-1-5 and as shown in Figure 4-19.

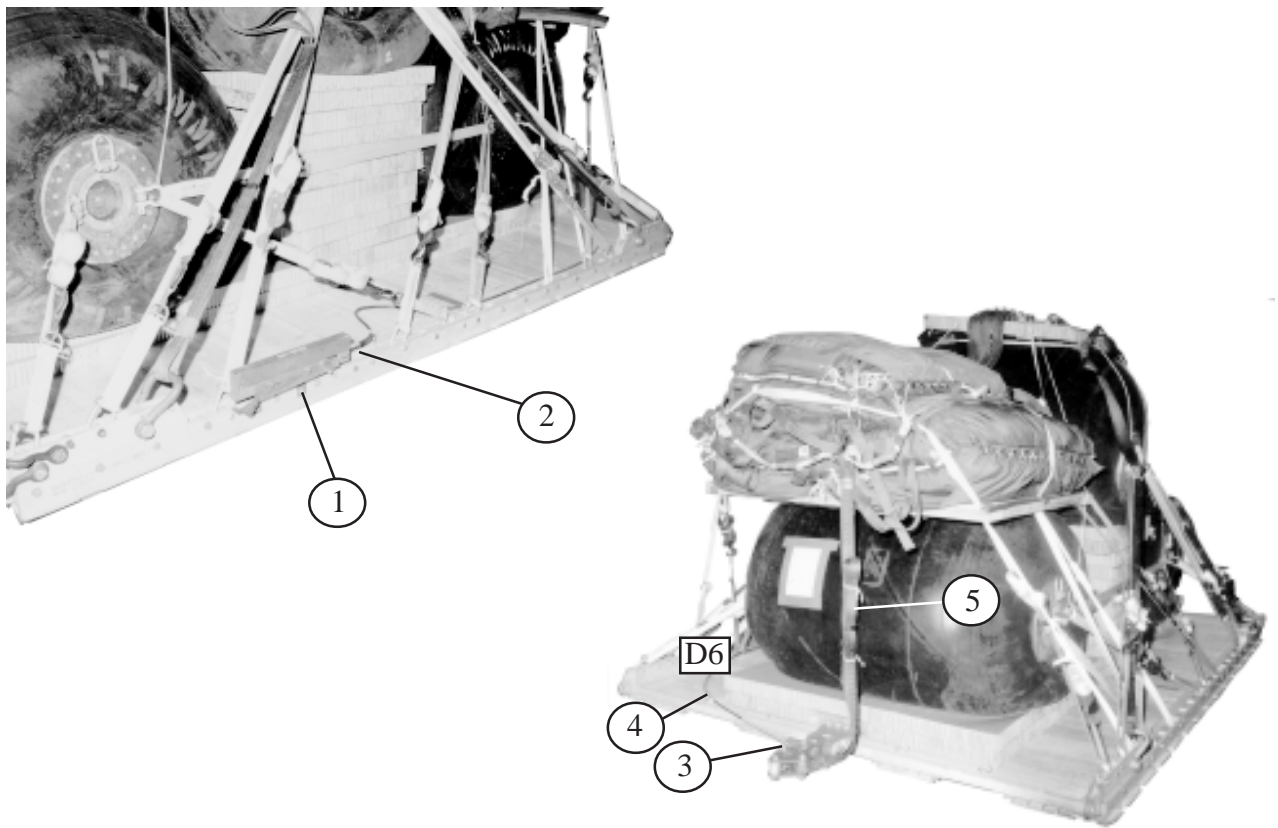

- ① Install the actuator mounting brackets to the front holes on the left platform rail.
- ② Install a 12-foot cable to the actuator. Install the actuator to the brackets.
- ③ Attach the latch assembly to the extraction bracket. Attach the cable to the latch assembly.
- ④ Safety the cable to tiedown ring D6 with type I, 1/4-inch cotton webbing.
- ⑤ Install a 9-foot (2-loop), type XXVI nylon webbing sling as the deployment line. S-fold and tie the excess in two places with type I, 1/4-inch cotton webbing.

Figure 4-19. EFTC installed

4-24. Installing Provisions for Emergency Restraints

Select and install provisions for emergency restraints according to the emergency aft restraint requirements table in FM 10-500-2/TO 13C7-1-5.

4-25. Placing Extraction Parachute

Select the extraction parachute and extraction line needed using the extraction line requirements table in FM 10-500-2/TO 13C7-1-5. Place the extraction parachute and extraction line on the load for installation in the aircraft.

4-26. Marking Rigged Load

Mark the rigged load according to FM 10-500-2/TO 13C7-1-5 and as shown in Figure 4-20.

CAUTION

The load weight may vary from the one shown, depending upon the fuel rigged. Be sure that the load is weighed, and the parachute requirements, CB, and tip-off curve recomputed.

4-27. Equipment Required

Use the equipment listed in Table 4-2 to rig this load.

CAUTION

Make the final rigger inspection required by FM 10-500-2/TO 13C7-1-5 before the load leaves the rigging site.

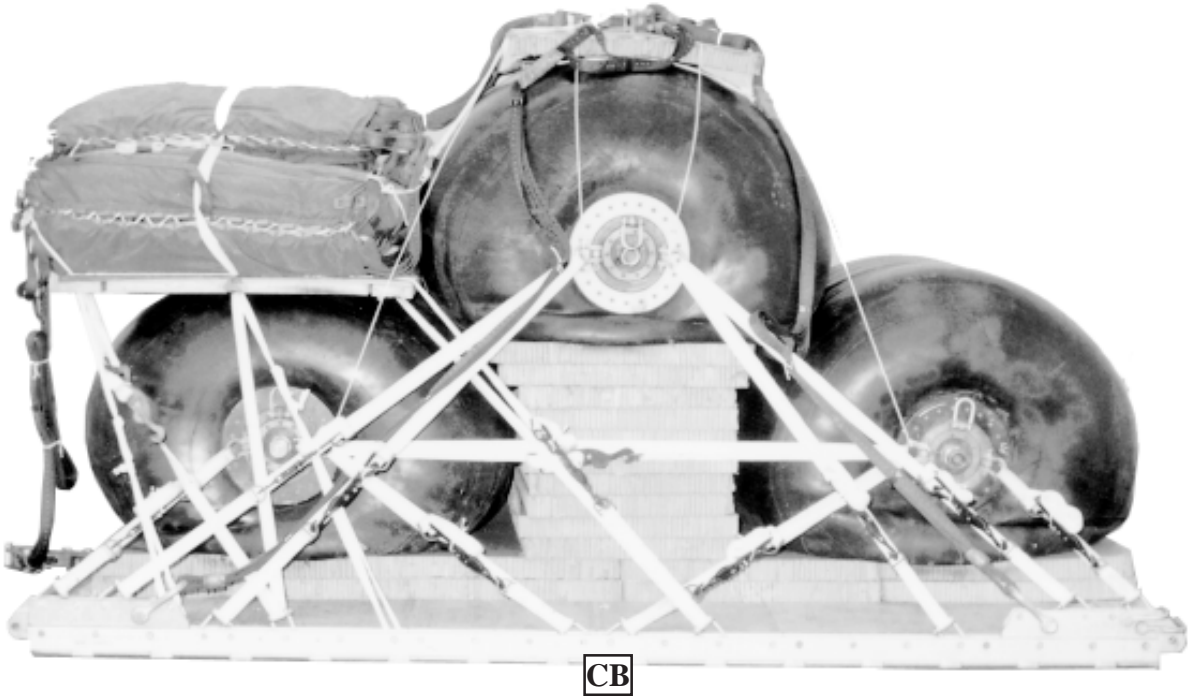

Rigged Load Data

Weight: Estimated, with gasoline	10,960 pounds
Maximum (as shown)	13,940 pounds
Height	86.5 inches
Width	108 inches
Length	144 inches
Overhang Front	5 inches
Rear	17 inches
CB (from front edge of platform)	75 inches
Extraction System (adds 18 inches to length of platform)	EFTC

Figure 4-20. Three drums without pumping assembly rigged on a 12-foot, type V airdrop platform for low-velocity airdrop

Table 4-2. Equipment required for rigging three drums without pumping assembly on a 12-foot, type V airdrop platform for low-velocity airdrop

National Stock Number	Item	Quantity
8040-00-273-8713	Adhesive, paste, 1-gal	As required
4030-00-678-8562	Clevis, suspension, 3/4-in (medium)	4
4030-00-090-5354	Clevis, suspension, 1-in (large)	5
4020-00-240-2146	Cord, nylon, type III, 550-lb	As required
1670-00-434-5783	Coupling, airdrop, extraction force transfer with cable, 12-ft	1
	Cover:	
1670-00-360-0328	Clevis, large	1
1670-00-360-0329	Link, type IV	7
1670-01-183-2678	Leaf, extraction line (line bag)	2
	Line, drogue (for C-17)	
1670-01-062-6316	60-ft (3-loop), type XXVI	1
	Line, extraction:	
1670-01-062-6316	60-ft (3-loop), type XXVI (for C-130)(Use w/ 140-ft for C-5)	1
1670-01-107-7651	140-ft (3-loop), type XXVI (for C-141B,C-5, or C-17)	1
	Link assembly:	
1670-00-783-5988	Type IV	7
	Two-point:	
5306-00-435-8994	Bolt, 1-in diam, 4-in long	2
5310-00-232-5165	Nut, 1-in, hexagonal	2
1670-00-003-1953	Plate, side, 3 3/4-in	2
5365-00-007-3414	Spacer, large	2
	Lumber:	
5510-00-220-6148	2- by 6- by 85-in	2
	by 48-in	2
5315-00-010-4659	Nail, steel wire, 8d	As required

Table 4-2. Equipment required for rigging three drums without pumping assembly on a 12-foot, type V airdrop platform for low-velocity airdrop (continued)

National Stock Number	Item	Quantity
1670-00-753-3928	Pad, energy-dissipating (honeycomb) 3- by 36- by 96-in	14 sheets
	Parachute:	
	Cargo:	
1670-01-016-7841	G-11B	3
	Cargo extraction:	
1670-01-063-3716	22-ft	1
	Drogue (for C-17)	
1670-01-063-3715	15-ft	1
	Platform, airdrop, type V, 12-ft	
1670-01-353-8425	Bracket assembly, coupling	(1)
1670-01-162-2372	Clevis assembly, type V	(20)
1670-01-162-2376	Extraction bracket assembly	(1)
1670-01-162-2381	Tandem link assembly (Multipurpose link)	(4)
5530-00-128-4981	Plywood, 3/4 -by 48- by 96-in	1 sheet
1670-01-097-8816	Release, cargo parachute, M-1	1
	Sling, cargo, airdrop	
	For suspension:	
1670-01-062-6303	12-ft (2-loop), type XXVI nylon webbing	
	For lifting:	
1670-01-062-6304	9-ft (2-loop), type XXVI nylon webbing	2
	For deployment:	
1670-01-062-6304	9-ft (2-loop), type XXVI nylon webbing	1
	For riser extension:	
1670-01-062-6302	20-ft (2-loop), type XXVI nylon webbing	6
5340-00-040-8219	Strap, parachute release, multi-cut, comes w/ 3 knives	2
7510-00-266-5016	Tape, adhesive, 2-in	As required
1670-00-937-0271	Tie-down assembly, 15-foot	18
	Webbing:	
8305-00-268-2411	Cotton, 1/4-in, type I	As required
8305-00-082-5752	Nylon, tubular, 1/2-in	As required
8305-00-263-3591	Type VIII	As required

Section III

RIGGING THREE DRUMS WITH PUMPING ASSEMBLY ON A 12-FOOT PLATFORM

4-28. Description of Load

Three drums are rigged with a pumping assembly on a 12-foot, type V platform. Filled with 432 gallons of gasoline, each drum weighs 2,842 pounds and is 62 inches long and 53 inches in diameter. An empty drum weighs 250 pounds.

Note: Fill drums with no more than 432 gallons of fuel. If the drums are filled with a fuel other than gasoline, the drum weight must be computed.

4-29. Preparing Platform

Prepare a 12-foot, type V airdrop platform using four tandem links and 26 clevises as shown in Figure 4-21.

Notes: 1. The nose bumper may or may not be installed.
2. Measurements given in this section are from the front edge of the platform, NOT from the front edge of the nose bumper.

WARNING

Do not add air to drums. Pressurization changes will cause leaking or bursting.

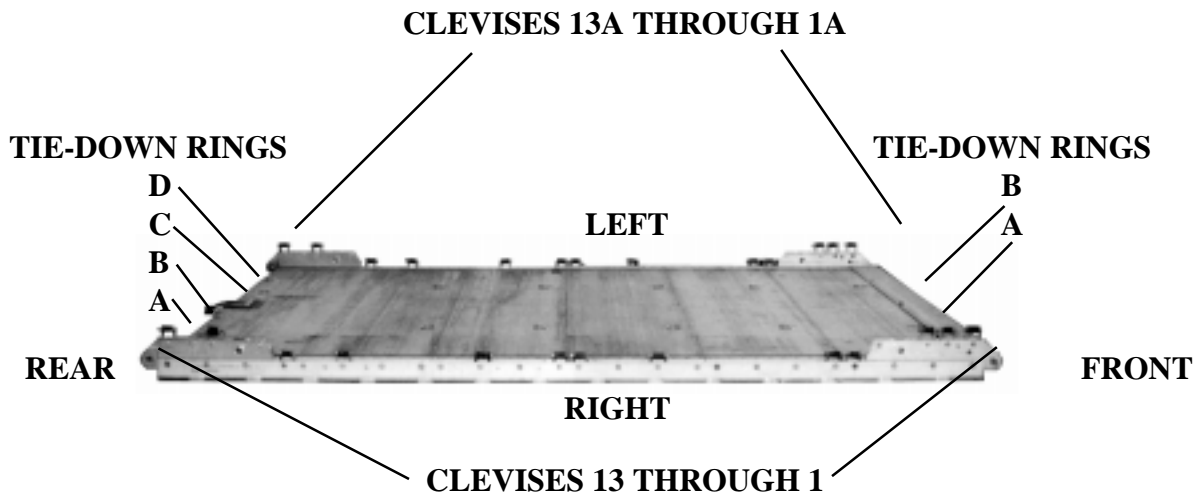

Step:

1. Inspect, or assemble and inspect, the platform as outlined in TM 10-1670-268-20&P/TO 13C7-52-22.
2. Install a tandem link on the front of each platform side rail using holes 1, 2, and 3. Install a tandem link on the rear of each platform side rail using holes 22, 23, and 24.
3. Bolt a clevis on bushings 1, 2 and 3 of each front tandem link, and on bushings 2 and 4 of each rear tandem link.
4. Starting at the front of the platform, install clevises on each platform side rail using the bushings bolted on holes 4, 5, 10, 12, 13, 15, 19 and 21.
5. Starting at the front of the platform, number the clevises bolted to the right side 1 through 13, and those bolted to the left side 1A through 13A.
6. Label the tiedown rings according to FM 1-500-2/TO 13C7-1-5.

Figure 4-21. Platform prepared

4-30. Preparing and Positioning Honeycomb Stacks

Prepare and position the honeycomb stacks as shown in Figure 4-12.

4-31. Installing Lifting Slings and Positioning Drums

Lift the drums and position them on the honeycomb as shown in Figure 4-13.

4-32. Lashing Drums

Use twenty-six 15-foot tiedown assemblies to lash the fuel drums to the platform as shown in Figure 4-22 and according to FM 10-500-2/TO 13C7-1-5.

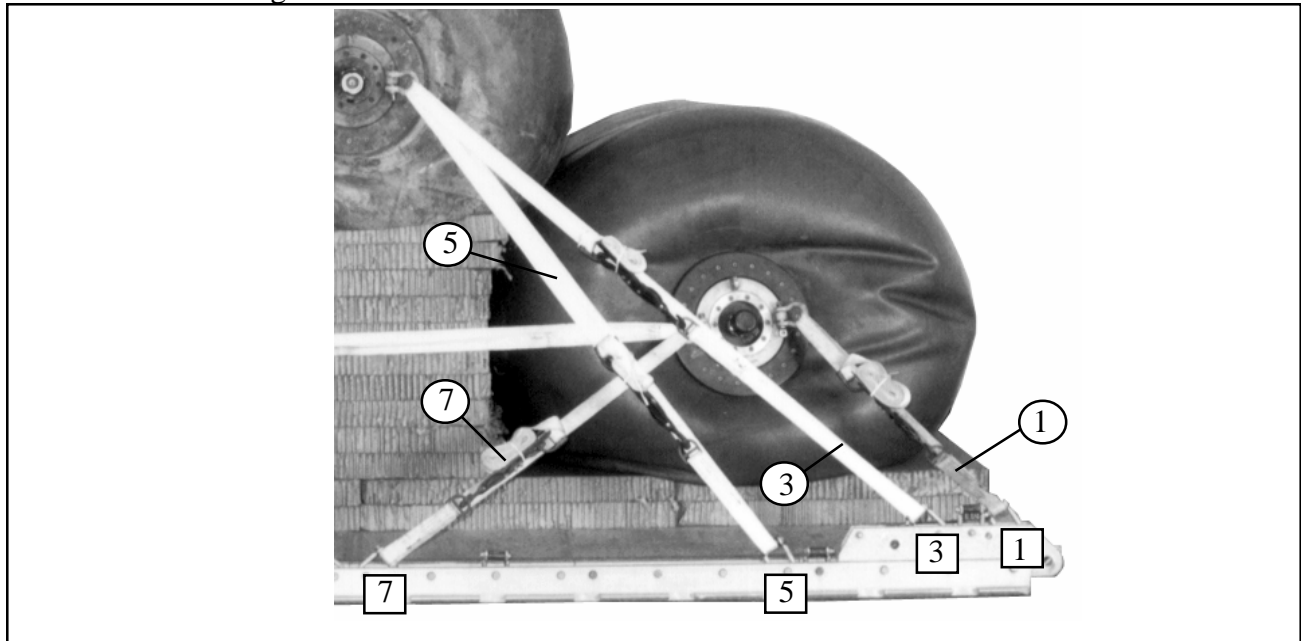

Lashing Number	Tie-down Clevis Number	Instructions
1	1	Pass lashing: Through right front shackle of front drum. Through left front shackle of front drum. Through right front shackle of center drum. Through left front shackle of center drum. Through right front shackle of center drum. Through left front shackle of center drum. Through right rear shackle of front drum. Through left rear shackle of front drum.
2	1A	
3	3	
4	3A	
5	5	
6	5A	
7	7	
8	7A	

Figure 4-22. Fuel drums lashed to platform

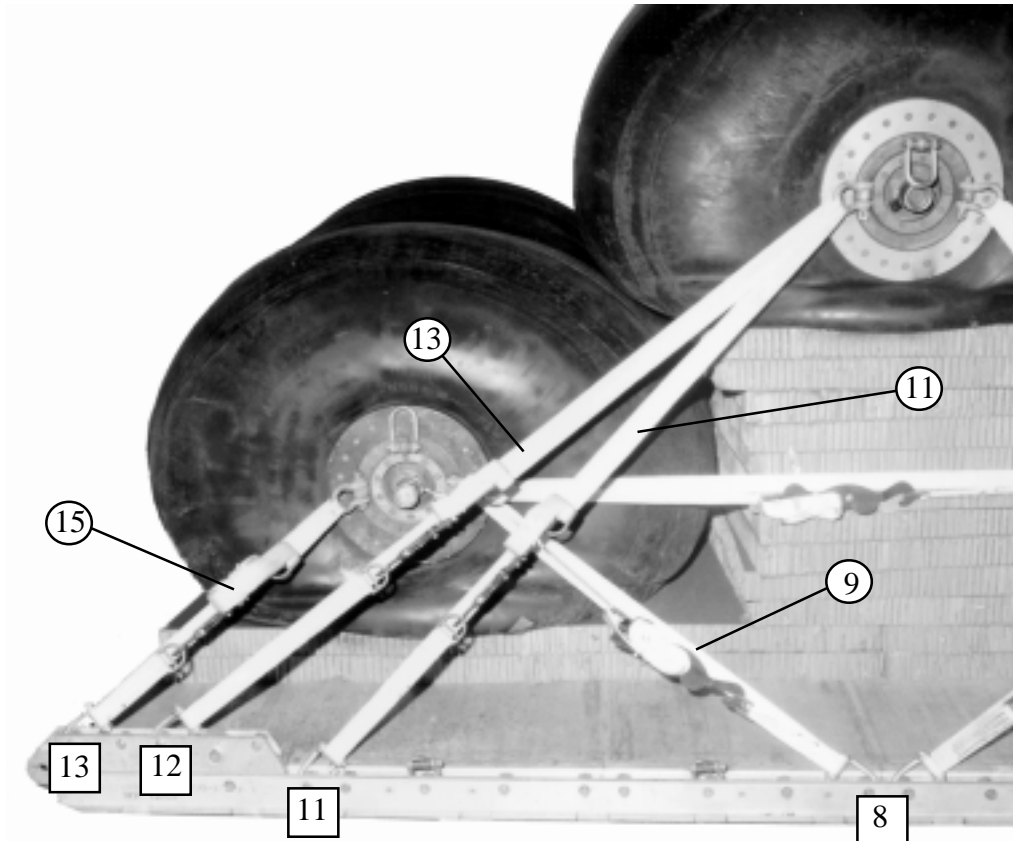

Lashing Number	Tie-down Clevis Number	Instructions
9	8	Pass lashing: Through right front shackle of rear drum.
10	8A	Through left front shackle of rear drum.
11	11	Through right rear shackle of center drum.
12	11A	Through left rear shackle of center drum.
13	12	Through right rear shackle of center drum.
14	12A	Through left rear shackle of center drum.
15	13	Through right rear shackle of rear drum.
16	13A	Through left rear shackle of rear drum.

Figure 4-22. Fuel drums lashed to platform (continued)

4-33. Preparing Pump Assembly

Build the box for the pump assembly as shown in Figure 4-23. Pack the pump, hoses, and equipment in the box as shown in Figure 4-24.

Notes: 1. These drawings are not to scale.
2. Use 8d nails.
3. All dimensions are in inches.

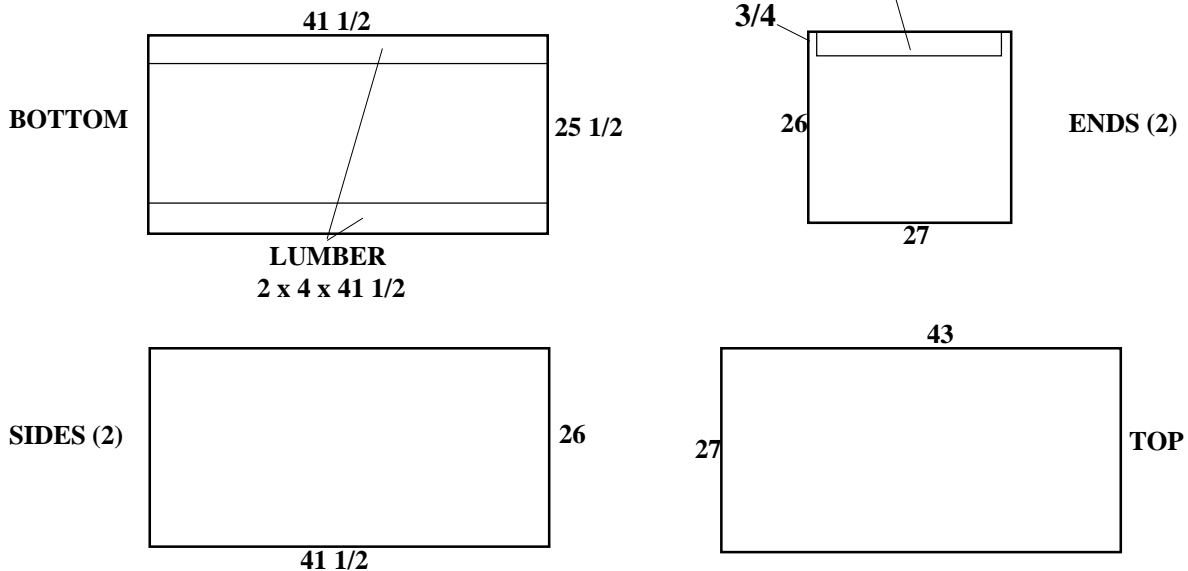

Step:

1. Cut the bottom of the box from 3/4-inch plywood 41 1/2 inches long and 25 1/2 inches wide. Nail a 41 1/2-inch length of 2- by 4-inch lumber flat side down and flush along each long edge of the bottom. The top of the box is 43- by 27 inches.
2. Cut the sides of the box from 3/4-inch plywood 41 1/2 inches long and 26 inches high. Place the sides flush with the bottom. Nail into the 2- by 4-inch pieces of lumber.
3. Cut the ends of the box from 3/4-inch plywood 27 inches wide and 26 inches high. Nail a piece of 2- by 4-inch lumber flat side down, centered, and flush with the top edge of each end piece. Nail the ends flush to the bottom and sides. Nail the sides to the 2- by 4-inch pieces of lumber on the ends.

Figure 4-23. Pump assembly box built

4-34. Lashing Pump Assembly to Platform

Place the pump assembly box on the load and lash it to the platform as shown in Figure 4-25.

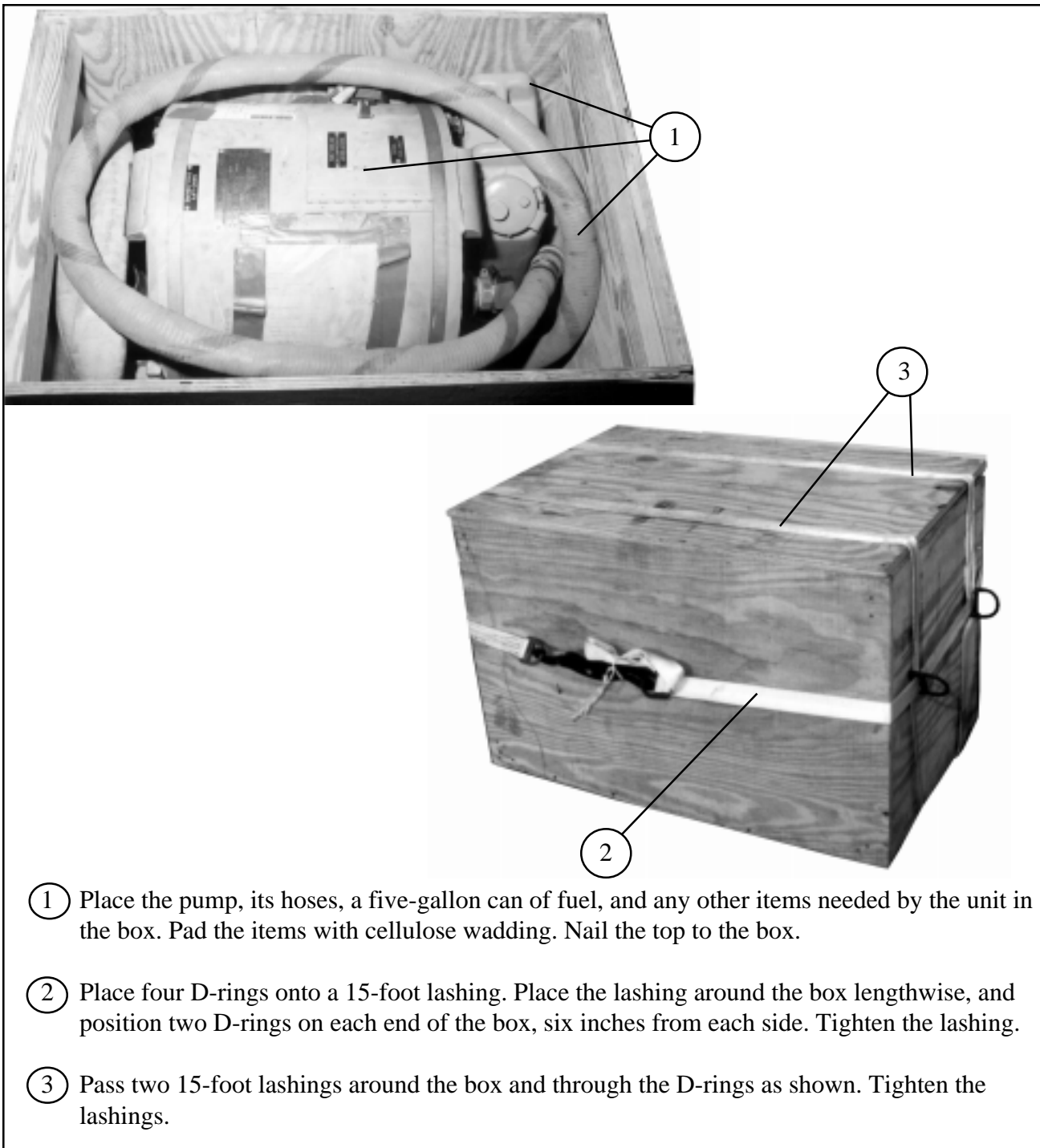
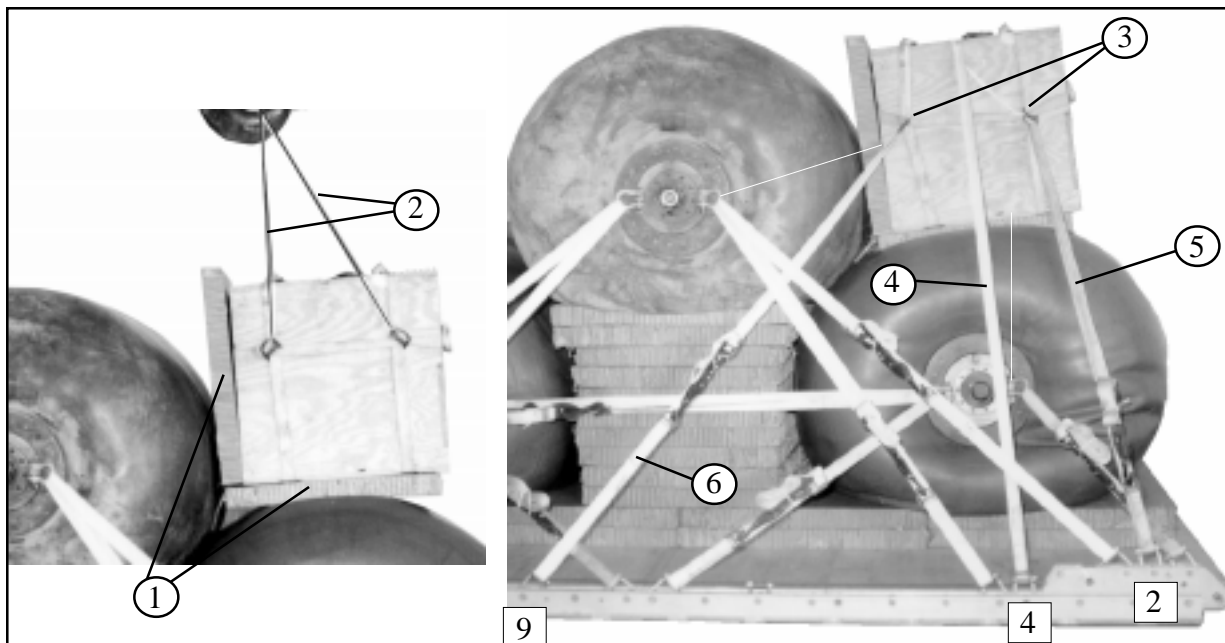

Figure 4-24. Pump assembly box packed



- ① Cut two pieces of honeycomb the dimensions of the bottom and side of the box.
- ② Lift the box onto the front drum using 1/2-inch tubular nylon webbing tied to the D-rings on the ends of the box. Place the honeycomb cut in step 1 between the box and the front and center drums. Secure the honeycomb in place with type III nylon cord.
- ③ Untie the 1/2-inch tubular nylon webbing placed in step 2 on one side. Retie the webbing tightly between the D-rings on opposite ends of the box to hold the D-rings in position when the box is lashed.
- ④ Pass a 15-foot lashing through clevis 4 and through its own D-ring. Pass a 15-foot lashing through clevis 4A and through its own D-ring. Secure the two lashings with two D-rings and a load binder on the left side of the load.
- ⑤ Pass a 15-foot lashing through clevis 2 and through the right front D-ring. Pass a 15-foot lashing through clevis 2A and through the left front D-ring. Tighten the lashings at the same time.
- ⑥ Pass a 15-foot lashing through clevis 9 and through the right rear D-ring. Pass a 15-foot lashing through clevis 9A and through the left rear D-ring. Tighten the lashings at the same time.

Figure 4-25. Pump assembly box lashed to platform

4-35. Installing and Safetying Suspension Slings

Install and safety four 12-foot (2-loop), type XXVI nylon webbing slings to the tandem links as shown in Figure 4-15.

4-36. Building and Lashing Parachute Stowage Platform

Build the parachute stowage platform and lash it to the load as shown in Figure 4-16.

4-37. Installing Cargo Parachutes

Install three G-11 cargo parachutes as shown in Figure 4-17 and according to FM 10-500-2/TO 13C7-1-5.

4-38. Installing Parachute Release

Prepare and install an M-1 cargo parachute release as shown in Figure 4-18 and according to FM 10-500-2/TO 13C7-1-5.

4-39. Installing Extraction System

Prepare and install the EFTC extraction system as shown in Figure 4-19 and according to FM 10-500-2/TO 13C7-1-5.

4-40. Installing Provisions for Emergency Restraints

Select and install provisions for emergency restraints according to the emergency aft restraint requirements table in FM 10-500-2/TO 13C7-1-5.

4-41. Placing Extraction Parachute

Select the extraction parachute and extraction line needed using the extraction line requirements table in FM 10-500-2/TO 13C7-1-5. Place the extraction parachute and extraction line on the load for installation in the aircraft.

4-42. Marking Rigged Load

Mark the rigged load according to FM 10-500-2/TO 13C7-1-5 and as shown in Figure 4-26.

CAUTION

The load weight may vary from the one shown, depending upon the fuel rigged. Be sure that the load is weighed, and the parachute requirements, CB, and tip-off curve recomputed.

4-43. Equipment Required

Use the equipment listed in Table 4-3 to rig this load.

CAUTION

Make the final rigger inspection required by FM 10-500-2/TO 13C7-1-5 before the load leaves the rigging site.

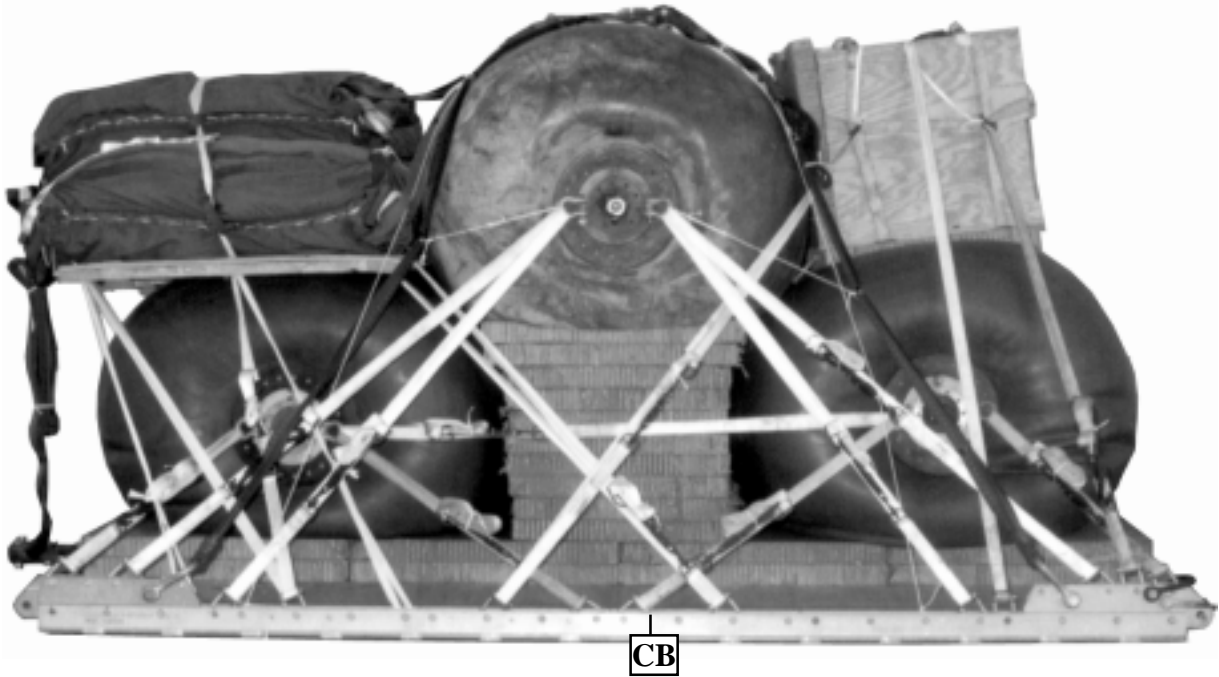
**Rigged Load Data**

Weight: Estimated, with gasoline	11,200 pounds
Maximum (as shown)	14,180 pounds
Height	86.5 inches
Width	108 inches
Length	144 inches
Overhang Front	5 inches
Rear	17 inches
CB (from front edge of platform)	74 inches
Extraction System (adds 18 inches to length of platform)	EFTC

Figure 4-26. Three drums with pumping assembly rigged on a 12-foot, type V airdrop platform for low-velocity airdrop.

Table 4-3. Equipment required for rigging three drums with pumping assembly on a 12-foot, type V airdrop platform for low-velocity airdrop

National Stock Number	Item	Quantity
8040-00-273-8713	Adhesive, paste, 1-gal	As required
4030-00-678-8562	Clevis, suspension, 3/4-in (medium)	4
4030-00-090-5354	Clevis, suspension, 1-in (large)	5
4020-00-240-2146	Cord, nylon, type III, 550-lb	As required
1670-00-434-5783	Coupling, airdrop, extraction force transfer with cable, 12-ft	1
	Cover:	
1670-00-360-0328	Clevis, large	1
1670-00-360-0329	Link, type IV	7
1670-01-183-2678	Leaf, extraction line (line bag)	2
	Line, drogue (for C-17)	
1670-01-062-6316	60-ft (3-loop), type XXVI	1
	Line, extraction:	
1670-01-062-6316	60-ft (3-loop), type XXVI (for C-130)(Use w/ 140-ft for C-5)	1
1670-01-107-7651	140-ft (3-loop), type XXVI (for C-141B,C-5, or C-17)	1
	Link assembly:	
1670-00-783-5988	Type IV	7
	Two-point:	
5306-00-435-8994	Bolt, 1-in diam, 4-in long	2
5310-00-232-5165	Nut, 1-in, hexagonal	2
1670-00-003-1953	Plate, side, 3 3/4-in	2
5365-00-007-3414	Spacer, large	2
	Lumber:	
5510-00-220-6146	2- by 4- by: 41 1/2-in	2
	25 1/2-in	2
5510-00-220-6148	2- by 6- by: 85-in	2
	48-in	2
5315-00-010-4659	Nail, steel wire, 8d	As required

Table 4-3. Equipment required for rigging three drums with pumping assembly on a 12-foot, type V airdrop platform for low-velocity airdrop (continued)

National Stock Number	Item	Quantity
1670-00-753-3928	Pad, energy-dissipating (honeycomb) 3- by 36- by 96-in	15 sheets
	Parachute:	
	Cargo:	
1670-01-016-7841	G-11B	3
	Cargo extraction:	
1670-01-063-3716	22-ft	1
	Drogue (for C-17)	
1670-01-063-3715	15-ft	1
	Platform, airdrop, type V, 12-ft	
1670-01-353-8425	Bracket assembly, coupling	(1)
1670-01-162-2372	Clevis assembly, type V	(26)
1670-01-162-2376	Extraction bracket assembly	(1)
1670-01-162-2381	Tandem link assembly (Multipurpose link)	(4)
5530-00-128-4981	Plywood, 3/4 -by 48- by 96-in	2 sheets
1670-01-097-8816	Release, cargo parachute, M-1	1
	Sling, cargo, airdrop	
	For suspension:	
1670-01-062-6303	12-ft (2-loop), type XXVI nylon webbing	
	For lifting:	
1670-01-062-6304	9-ft (2-loop), type XXVI nylon webbing	2
	For deployment:	
1670-01-062-6304	9-ft (2-loop), type XXVI nylon webbing	1
	For riser extension:	
1670-01-062-6302	20-ft (2-loop), type XXVI nylon webbing	6
5340-00-040-8219	Strap, parachute release, multi-cut, comes w/ 3 knives	2
7510-00-266-5016	Tape, adhesive, 2-in	As required
1670-00-937-0271	Tie-down assembly, 15-foot	29
	Webbing:	
8305-00-268-2411	Cotton, 1/4-in, type I	As required
8305-00-082-5752	Nylon, tubular, 1/2-in	As required
8305-00-263-3591	Type VIII	As required

Section IV

**RIGGING FOUR DRUMS WITHOUT PUMPING ASSEMBLY
ON A 20-FOOT PLATFORM**

4-44. Description of Load

Four drums are rigged on a 20-foot, type V platform. Filled with 432 gallons of gasoline, each drum weighs 2,842 pounds and is 62 inches long and 53 inches in diameter. An empty drum weighs 250 pounds.

Note: Fill drums with no more than 432 gallons of fuel. If the drums are filled with a fuel other than gasoline, the drum weight must be computed.

4-45. Preparing Platform

Prepare a 20-foot, type V airdrop platform using two tandem links, four suspension links and 20 clevises as shown in Figure 4-27.

Notes: 1. The nose bumper may or may not be installed.
2. Measurements given in this section are from the front edge of the platform, NOT from the front edge of the nose bumper.

WARNING

Do not add air to drums. Pressurization changes will cause leaking or bursting.

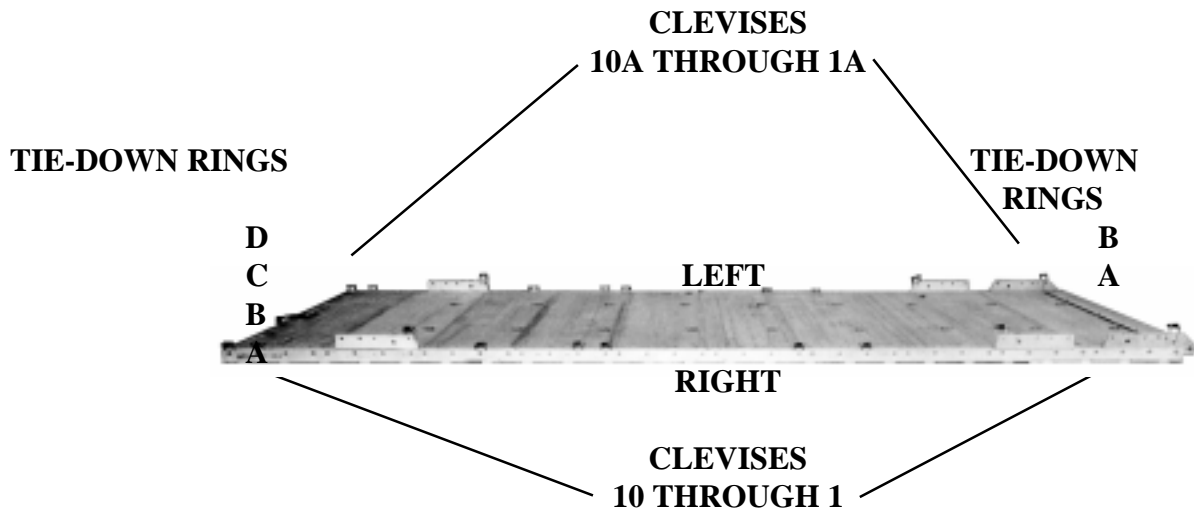

Step:

1. Inspect, or assemble and inspect, the platform as outlined in TM 10-1670-268-20&P/TO 13C7-52-22.
2. Install a suspension link on each platform side rail using holes 6, 7, and 8.
3. Install a tandem link on the front of each platform side rail using holes 1, 2, and 3.
4. Install a suspension link on each platform side rail using holes 33, 34, and 35.
5. Bolt a clevis on bushing 1 of each front tandem link, on bushing 4 of each first suspension link, and on bushing 1 of each rear suspension link.
6. Starting at the front of the platform, install clevises on each platform side rail using the bushings bolted on holes 14, 17, 25, 26, 30, 39, and 40.
7. Starting at the front of the platform, number the clevises bolted to the right side 1 through 10, and those bolted to the left side 1A through 10A.
8. Label the tiedown rings according to FM 10-500-2/TO 13C7-1-5.

Figure 4-27. Platform prepared

4-46. Preparing and Positioning Honeycomb Stack

Prepare and position the honeycomb stack as shown in Figure 4-28.

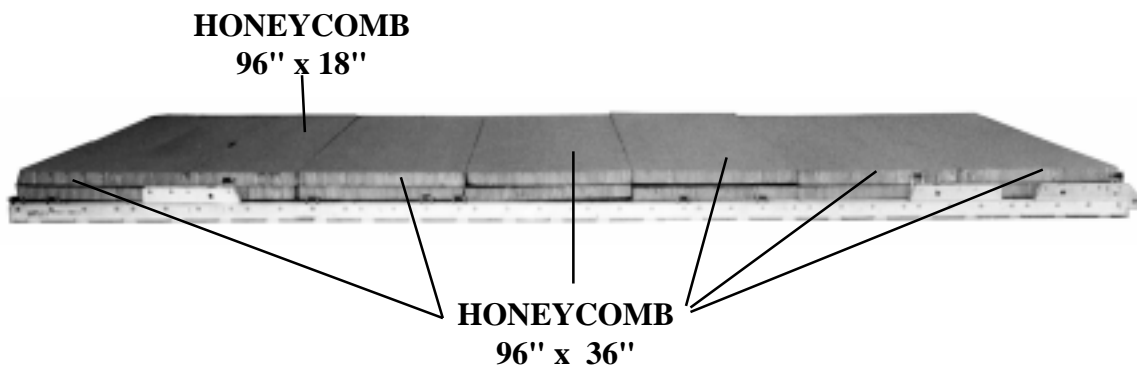

- ① Use 12 full sheets of honeycomb and two 18- by 96 inch pieces to form a two-layer stack 234 inches long and 96 inches wide. Center the stack on the platform 3 inches from the front edge.

Note: Place the 18-inch section inside the stack.

Figure 4-28. Honeycomb stack positioned

4-47. Installing Lifting Slings and Positioning Drums

Lift the drums and position them on the honeycomb as shown in Figure 4-29.

4-48. Lashing Drums

Use twenty 15-foot tie-down assemblies to lash the fuel drums as shown in Figure 4-30, and according to FM 10-500-2/TO 13C7-1-5.

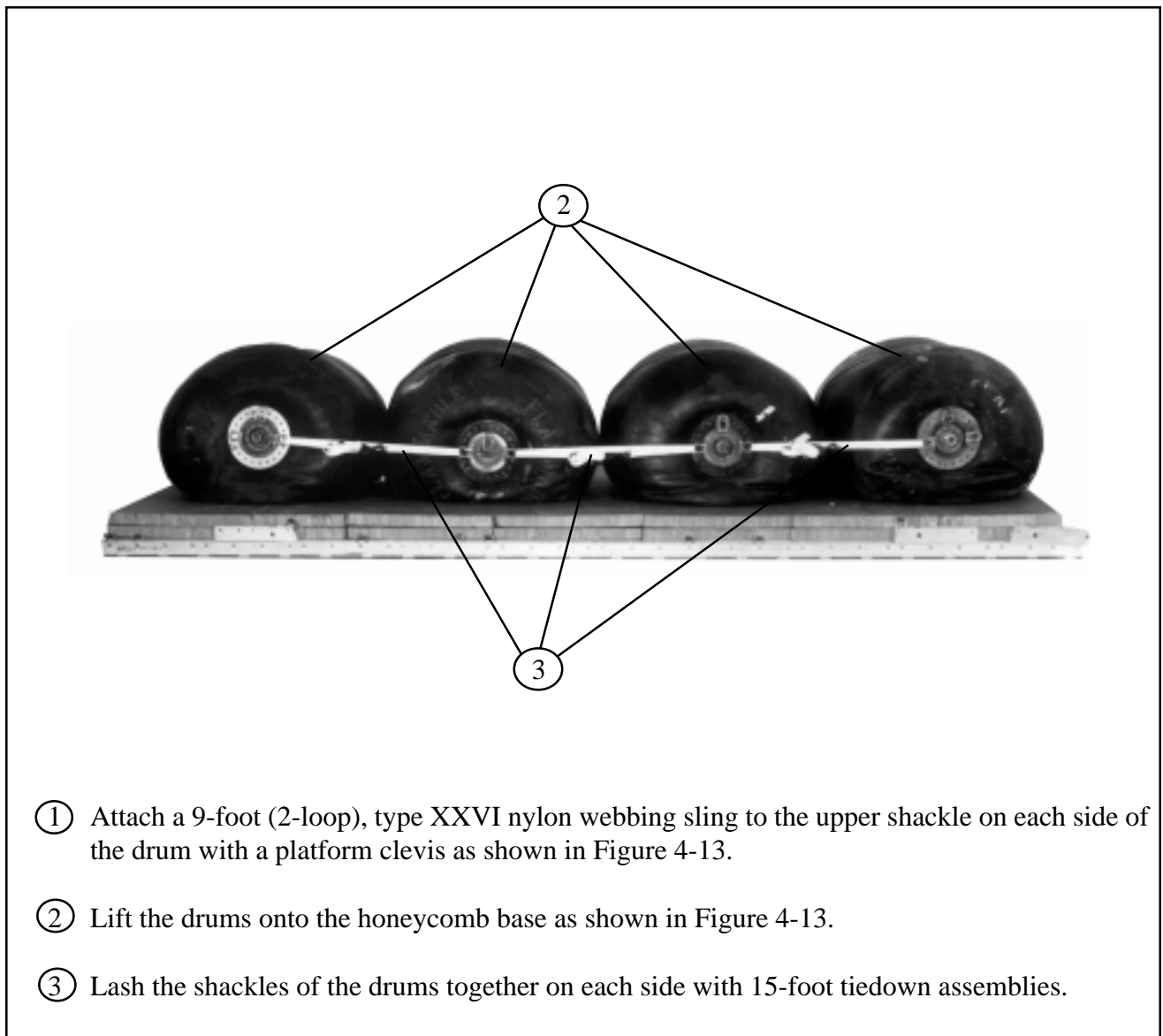

- ① Attach a 9-foot (2-loop), type XXVI nylon webbing sling to the upper shackle on each side of the drum with a platform clevis as shown in Figure 4-13.
- ② Lift the drums onto the honeycomb base as shown in Figure 4-13.
- ③ Lash the shackles of the drums together on each side with 15-foot tiedown assemblies.

Figure 4-29. Fuel drums positioned

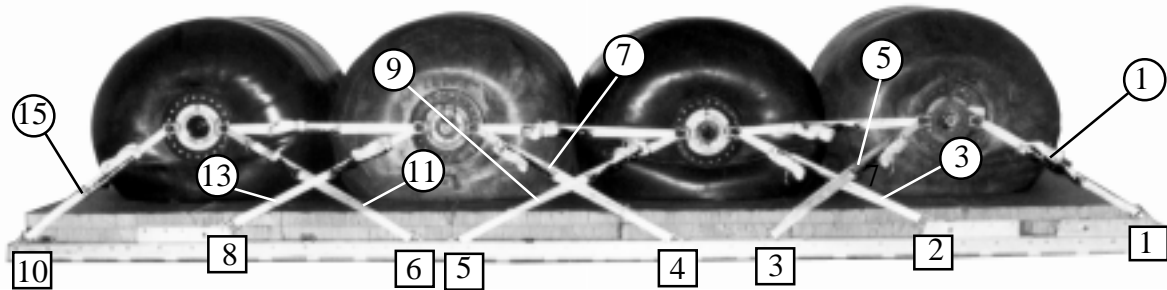

Lashing Number	Tie-down Clevis Number	Instructions
1	1	Pass lashing: Through right front shackle of first drum.
2	1A	Through left front shackle of first drum.
3	2	Through right front shackle of second drum.
4	2A	Through left front shackle of second drum.
5	3	Through right rear shackle of first drum.
6	3A	Through left rear shackle of first drum.
7	4	Through right front shackle of third drum.
8	4A	Through left front shackle of third drum.
9	5	Through right rear shackle of second drum.
10	5A	Through left rear shackle of second drum.
11	6	Through right front shackle of fourth drum.
12	6A	Through left front shackle of fourth drum.
13	8	Through right rear shackle of third drum.
14	8A	Through left rear shackle of third drum.
15	10	Through right rear shackle of fourth drum.
16	10A	Through left rear shackle of fourth drum.

Figure 4-30. Fuel drums lashed to platform

4-49. Installing and Safetying Suspension Slings

Install and safety four 16-foot (4-loop), type XXVI nylon webbing slings to the suspension links as shown in Figure 4-31.

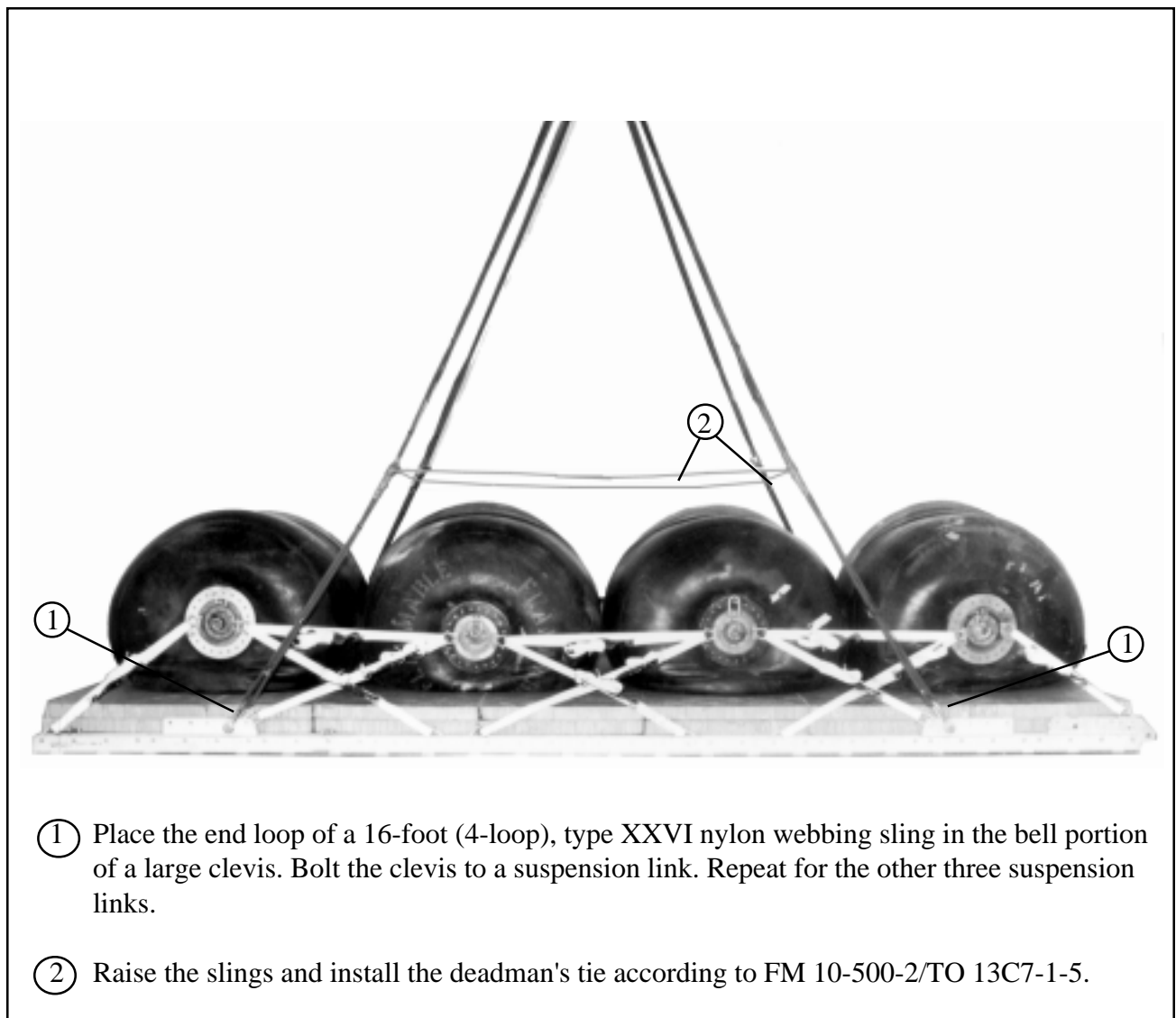
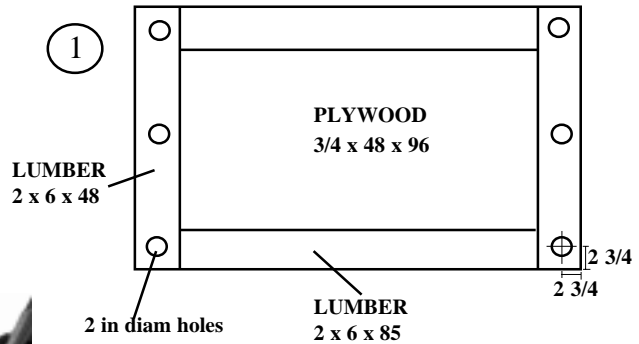
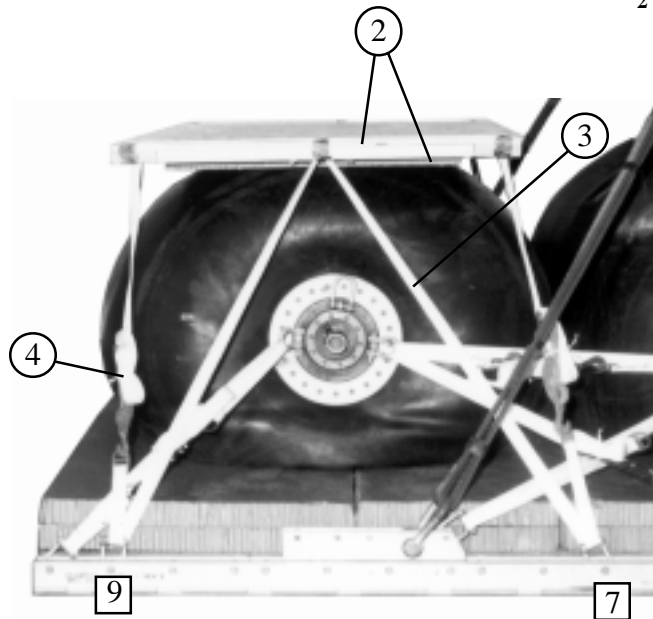

Figure 4-31. Suspension slings installed and safetyed

4-50. Building and Lashing Parachute Stowage Platform

Build the parachute stowage platform and lash it to the load with four 15-foot lashings as shown in Figure 4-32.

Notes: 1. This drawing is not to scale.
 2. All dimensions are given in inches.
 3. Use eightpenny nails.



- ① Build the parachute stowage platform as shown. Nail the 2- by 6-inch pieces of lumber to the edges of the plywood and drill 2-inch holes for the lashings.
- ② Center a 36- by 85-inch piece of honeycomb over the rear drum. Place the parachute stowage platform on the drum over the honeycomb.
- ③ Lash the two front holes in the parachute stowage platform to clevises 7 and 7A.
- ④ Lash the two rear holes in the parachute stowage platform to clevises 9 and 9A.

Figure 4-32. Parachute stowage platform built and lashed

4-51. Installing Cargo Parachutes

Install four G-11 cargo parachutes as shown in Figure 4-33 and according to FM 10-500-2/TO 13C7-1-5.

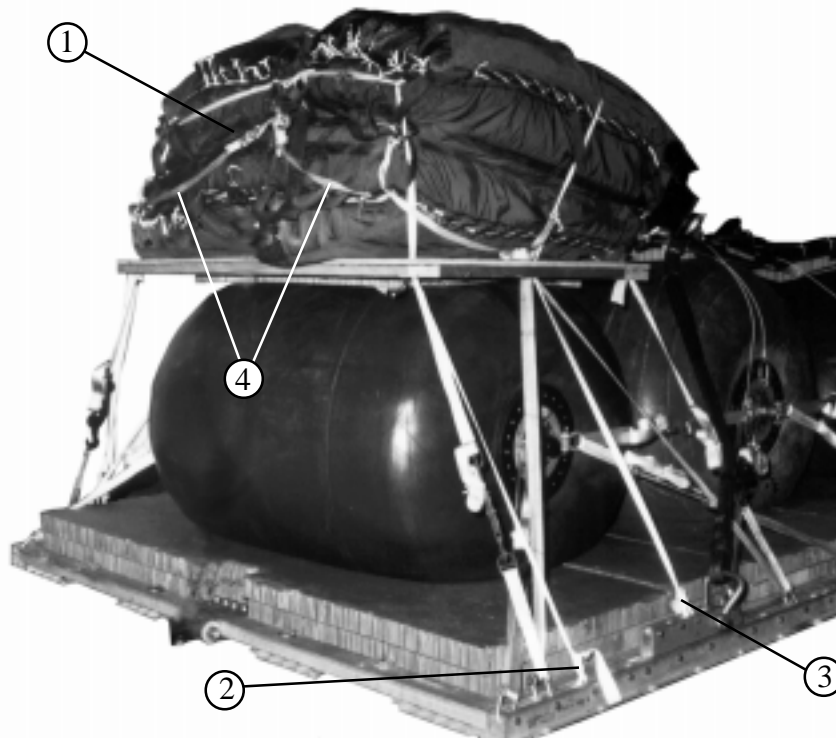

- ① Cluster four G-11 cargo parachutes on the parachute stowage platform.
- ② Pass the rear restraint strap through the rear holes in the parachute stowage platform, and tie the ends to the 38th bushing on each side rail.
- ③ Pass the front restraint strap through the center holes in the parachute stowage platform, and tie the ends to the second bushing on each rear suspension link.
- ④ Install the parachute release knives according to FM 10-500-2/TO 13C7-1-5.

Figure 4-33. G-11 cargo parachutes installed

4-52. Installing Parachute Release

Prepare and install an M-2 cargo parachute release as shown in Figure 4-34 and according to FM 10-55-2/TO 13C7-1-5.

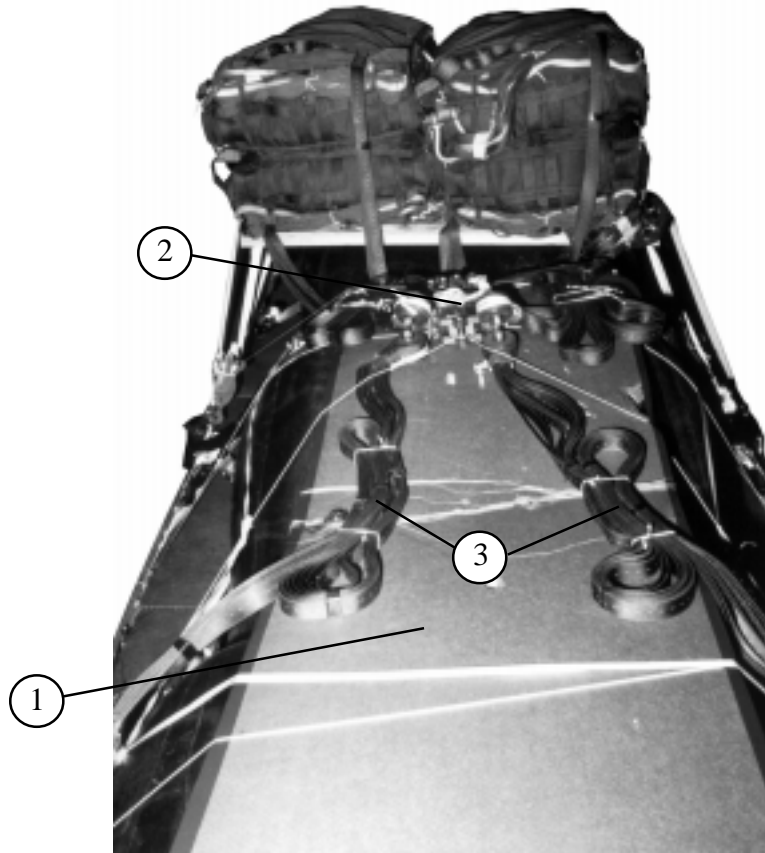

- ① Center a 36- by 96-inch piece of honeycomb over the second and third drums. Secure the honeycomb to the platform with type III nylon cord.
- ② Attach the suspension slings and the riser extensions to the M-2 release according to FM 10-500-2/TO 13C7-1-5. Secure the release to the platform with type III nylon cord.
- ③ S-fold the suspension slings and tie the folds with type I, 1/4-inch cotton webbing.

Figure 4-34. M-2 release installed

4-53. Installing Extraction System

Prepare and install the EFTC extraction system as shown in Figure 4-35 and as shown in FM 10-500-2/TO 13C7-1-5.

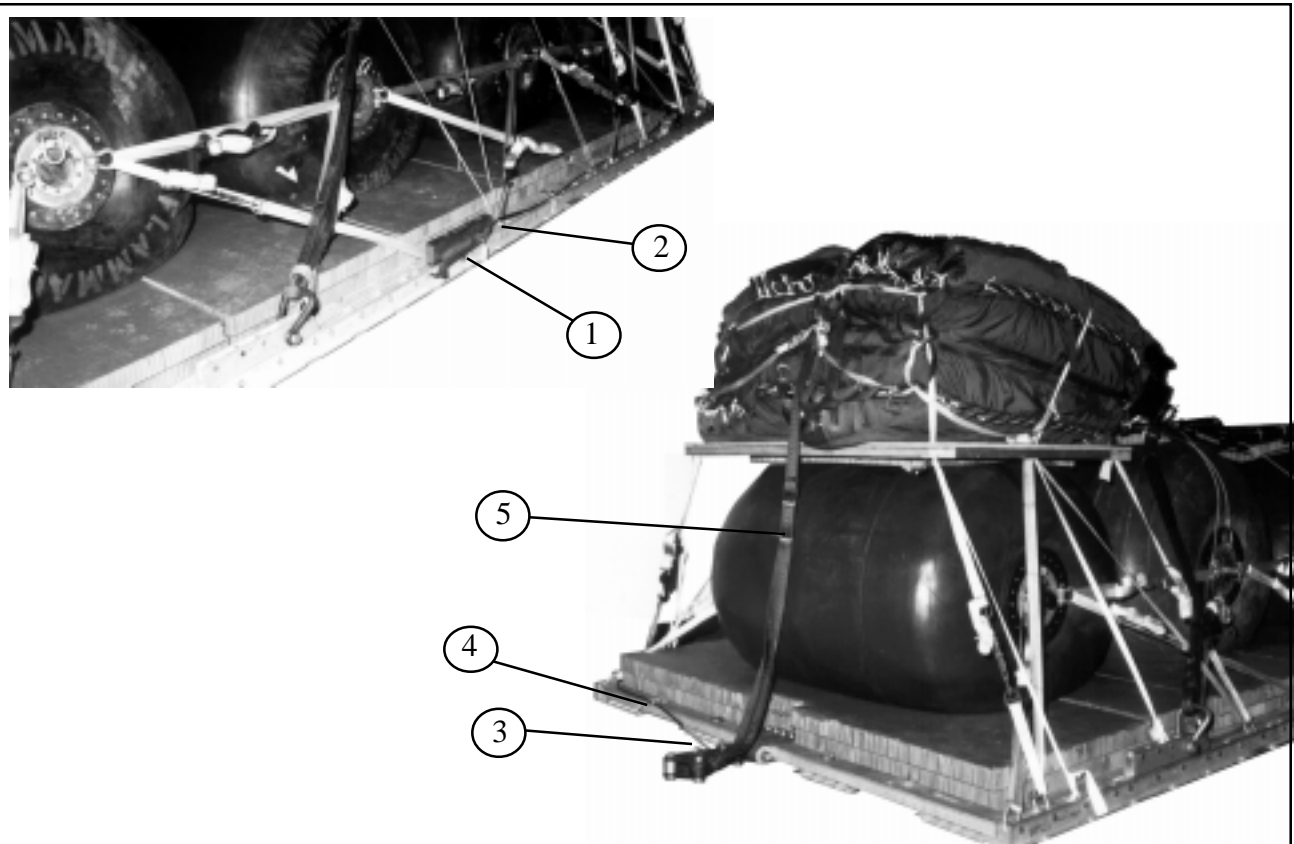

- ① Install the actuator mounting brackets to the front holes on the left platform rail.
- ② Install a 20-foot cable to the actuator. Install the actuator to the brackets.
- ③ Attach the latch assembly to the extraction bracket. Attach the cable to the latch assembly.
- ④ Safety the cable to tiedown ring D10 with type I, 1/4inch cotton webbing.
- ⑤ Install a 9-foot (2-loop), type XXVI nylon webbing sling as the deployment line. S-fold and tie the excess in two places with type I, 1/4-inch cotton webbing.

Figure 4-35. EFTC installed

4-54. Installing Provisions for Emergency Restraints

Select and install provisions for emergency restraint according to the emergency aft restraint requirements table in FM 10-500-2/TO 13C7-1-5.

4-55. Placing Extraction Parachute

Select the extraction parachute and extraction line needed using the extraction line requirements table in FM 10-500-2/TO 13C7-1-5. Place the extraction parachute and extraction line on the load for installation in the aircraft.

4-56. Marking Rigged Load

Mark the rigged load according to FM 10-500-2/TO 13C7-1-5 and as shown in Figure 4-36.

CAUTION

The load weight may vary from the one shown, depending upon the fuel rigged. Be sure that the load is weighed, and the parachute requirements, CB, and tip-off curve recomputed.

4-57. Equipment Required

Use the equipment listed in Table 4-4 to rig this load.

CAUTION
 Make the final rigger inspection required by FM 10-500-2/TO 13C7-1-5
 before the load leaves the rigging site.

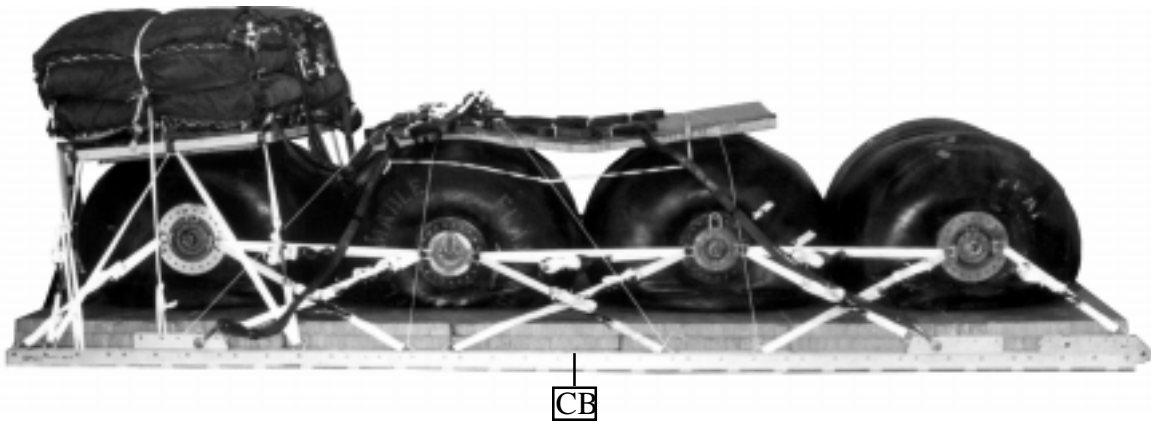

Rigged Load Data

Weight: Estimated, with gasoline	14,426 pounds
Maximum (as shown)	18,400 pounds
Height	90.5 inches
Width	108 inches
Length	240 inches
Overhang Front	5 inches
Rear	17 inches
CB (from front edge of platform)	125 inches
Extraction System (adds 18 inches to length of platform)	EFTC

Figure 4-36. Four drums rigged on a 20-foot, type V airdrop platform for low-velocity airdrop

Table 4-4. Equipment required for rigging four drums without pumping assembly on a 20-foot, type V airdrop platform for low-velocity airdrop

National Stock Number	Item	Quantity
8040-00-273-8713	Adhesive, paste, 1-gal	As required
4030-00-678-8562	Clevis, suspension, 3/4-in (medium)	6
4030-00-090-5354	Clevis, suspension, 1-in (large)	5
4020-00-240-2146	Cord, nylon, type III, 550-lb	As required
1670-00-434-5787	Coupling, airdrop, extraction force transfer with cable, 20-ft	1
	Cover:	
1670-00-360-0328	Clevis, large	1
1670-00-360-0329	Link, type IV	9
1670-01-183-2678	Leaf, extraction line (line bag)	2
	Line, drogue (for C-17)	
1670-01-062-6316	60-ft (3-loop), type XXVI	1
	Line, extraction:	
1670-01-062-6316	60-ft (3-loop), type XXVI (for C-130)(Use w/ 140-ft for C-5)	1
1670-01-107-7651	140-ft (3-loop), type XXVI (for C-141B,C-5, or C-17)	1
	Link assembly:	
1670-00-783-5988	Type IV	9
	Two-point:	
5306-00-435-8994	Bolt, 1-in diam, 4-in long	2
5310-00-232-5165	Nut, 1-in, hexagonal	2
1670-00-003-1954	Plate, side, 5 1/2-in	2
5365-00-007-3414	Spacer, large	2
	Lumber:	
	2- by 6- by:	
	85-in	2
	48-in	2
5315-00-010-4659	Nail, steel wire, 8d	As required

Table 4-4. Equipment required for rigging four drums without pumping assembly on a 20-foot, type V airdrop platform for low-velocity airdrop (continued)

National Stock Number	Item	Quantity
1670-00-753-3928	Pad, energy-dissipating (honeycomb) 3- by 36- by 96-in	15 sheets
1670-01-016-7841	Parachute: Cargo: G-11B	4
1670-01-063-3716	Cargo extraction: 22-ft (option for C-141 and C-5)	1
1670-00-040-8135	28-ft (for C-130 and C-17, option for C-141 and C-5)	1
1670-01-063-3715	Drogue (for C-17) 15-ft	1
1670-01-353-8425	Platform, airdrop, type V, 20-ft Bracket assembly, coupling	(1)
1670-01-162-2372	Clevis assembly, type V	(20)
1670-01-162-2376	Extraction bracket assembly	(1)
1670-01-162-2381	Tandem link assembly (Multipurpose link)	(2)
1670-01-247-2389	Suspension link	(4)
5530-00-128-4981	Plywood, 3/4 -by 48- by 96-in	1 sheet
1670-01-097-8817	Release, cargo parachute, M-2	1
1670-01-062-6308	Sling, cargo, airdrop For suspension: 16-ft (4-loop), type XXVI nylon webbing	4
1670-01-062-6304	For lifting: 9-ft (2-loop), type XXVI nylon webbing	2
1670-01-062-6304	For deployment: 9-ft (2-loop), type XXVI nylon webbing	1
1670-01-062-6302	For riser extension: 20-ft (2-loop), type XXVI nylon webbing	8
5340-00-040-8219	Strap, parachute release, multi-cut, comes w/ 3 knives	2
7510-00-266-5016	Tape, adhesive, 2-in	As required
1670-00-937-0271	Tie-down assembly, 15-foot	26
8305-00-268-2411	Webbing: Cotton, 1/4-in, type I	As required
8305-00-082-5752	Nylon, tubular, 1/2-in	As required
8305-00-263-3591	Type VIII	As required

Section V

**RIGGING FIVE DRUMS WITHOUT PUMPING ASSEMBLY
ON A 20-FOOT PLATFORM**

4-58. Description of Load

Five drums are rigged on a 20-foot, type V platform. Filled with 432 gallons of gasoline, each drum weighs 2,842 pounds and is 62 inches long and 53 inches in diameter. An empty drum weighs 250 pounds.

Note: Fill drums with no more than 432 gallons of fuel. If the drums are filled with a fuel other than gasoline, the drum weight must be computed.

4-59. Preparing Platform

Prepare a 20-foot, type V airdrop platform using two tandem links, eight suspension links and 42 clevises as shown in Figure 4-37.

**Notes: 1. The nose bumper may or may not be installed.
2. Measurements given in this section are from the front edge of the platform, NOT from the front edge of the nose bumper.**

WARNING

Do not add air to drums. Pressurization changes will cause leaking or bursting.

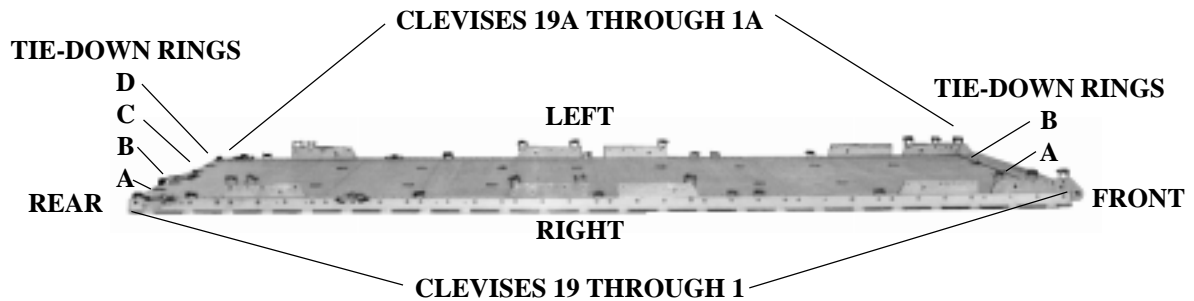

Step:

1. Inspect, or assemble and inspect, the platform as outlined in TM 10-1670-268-20&P/ TO 13C7-52-22.
2. Install suspension links on each platform side rail using holes 17, 18, and 19, and holes 5, 6, and 7.
3. Install a tandem link on the front of each platform side rail using holes 1, 2, and 3.
4. Install suspension links on each platform side rail using holes 22, 23, and 24, and holes 34, 35, and 36.
5. Bolt clevises on bushings 1, 2, and 3 of each front tandem link, on bushing 1 of each second suspension link, on bushings 1 and 4 of each third suspension link, and on bushings 3 and 4 of each rear suspension link.
6. Install clevises on bushings 31 and 39 in an inverted position on each platform side rail. Bolt two additional clevises to each inverted clevis.
7. Starting at the front of the platform, install clevises on each platform side rail using the bushings bolted on holes 9, 14, 15, 21, 28, 38, and 40.
8. Starting at the front of the platform, number the clevises bolted to the right side 1 through 19, and those bolted to the left side 1A through 19A.
9. Label the tiedown rings according to FM 10-500-2/TO 13C7-1-5.

Figure 4-37. Platform prepared

4-60. Preparing and Positioning Honeycomb Stack

Prepare and position the honeycomb stack as shown in Figure 4-38.

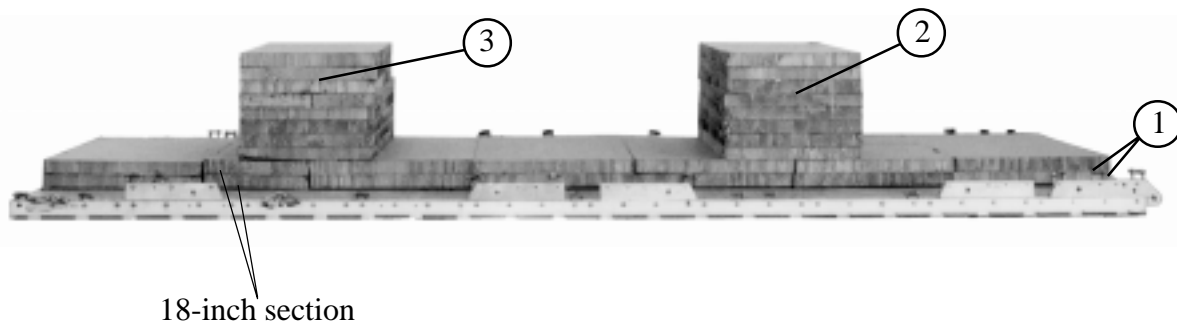

- ① Use 12 sheets of honeycomb 36- by 60 inches and two pieces 18- by 96 inches to form a two-layer stack 234 inches long and 60 inches wide. Center the stack on the platform 3 inches from the front edge.

Note: Place the 18-inch section inside the stack.

- ② Make two 8-layer stacks of honeycomb 60- by 30 inches. Center one stack on the base layer 62 1/2 inches from the front edge of the base.
- ③ Center the other stack on the base layers 55 1/2 inches to the rear of the stack placed in step 2 above.

Figure 4-38. Honeycomb stack positioned

4-61. Installing Lifting Slings and Positioning Drums

Lift the drums and position them on the honeycomb as shown in Figure 4-39.

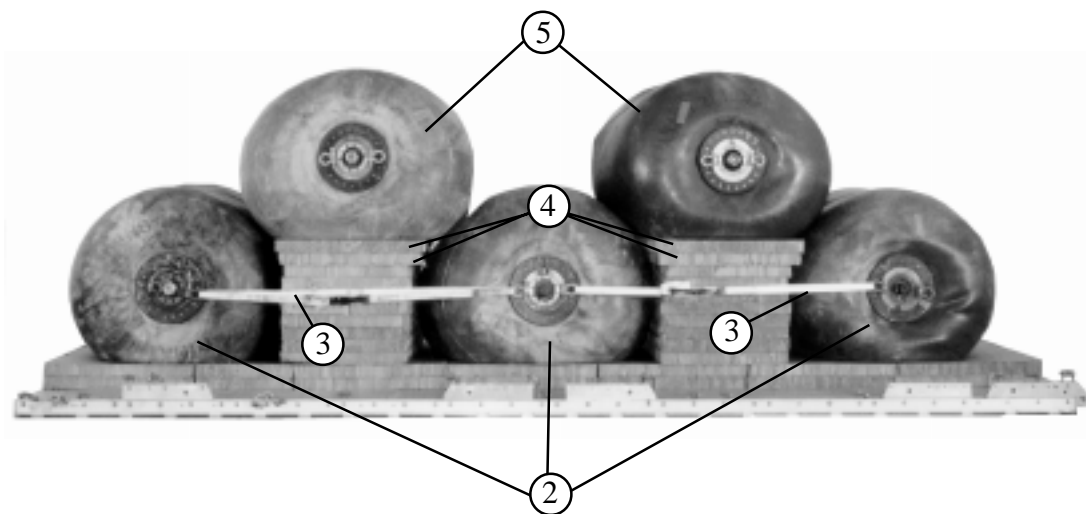

- ① Attach a 9-foot (2-loop), type XXVI nylon webbing sling to the upper shackle on each side of the drum with a platform clevis as shown in Figure 4-13.
- ② Lift three drums onto the honeycomb base as shown in Figure 4-13.
- ③ Lash the shackles of the drums together on each side with 15-foot tiedown assemblies.
- ④ Glue a 60- by 34-inch piece of honeycomb centered on each stack. Glue a 60- by 36-inch piece of honeycomb centered over the pieces placed previously.
- ⑤ Lift and position a drum onto each stack.

Figure 4-39. Fuel drums positioned

4-62. Lashing Drums

Use thirty 15-foot tie-down assemblies to lash the fuel drums as shown in Figure 4-40, and according to FM 10-500-2/TO 13C7-1-5.

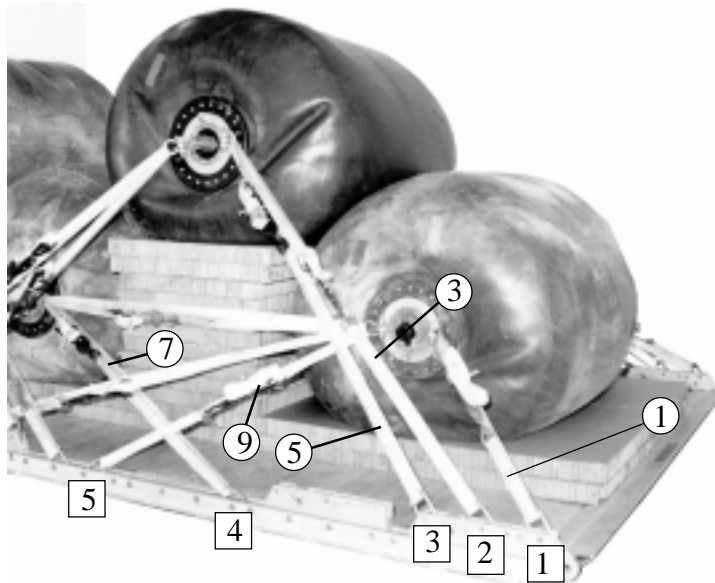

Lashing Number	Tie-down Clevis Number	Instructions
1	1	Pass lashing:
2	1A	Through right front shackle of first drum.
3	2	Through left front shackle of first drum.
4	2A	Through right front shackle of second drum.
5	3	Through left front shackle of second drum.
6	3A	Through right front shackle of second drum.
7	4	Through left front shackle of second drum.
8	4A	Through right front shackle of third drum.
9	5	Through left front shackle of third drum.
10	5A	Through right rear shackle of first drum.
		Through left rear shackle of first drum.

Figure 4-40. Fuel drums lashed to platform

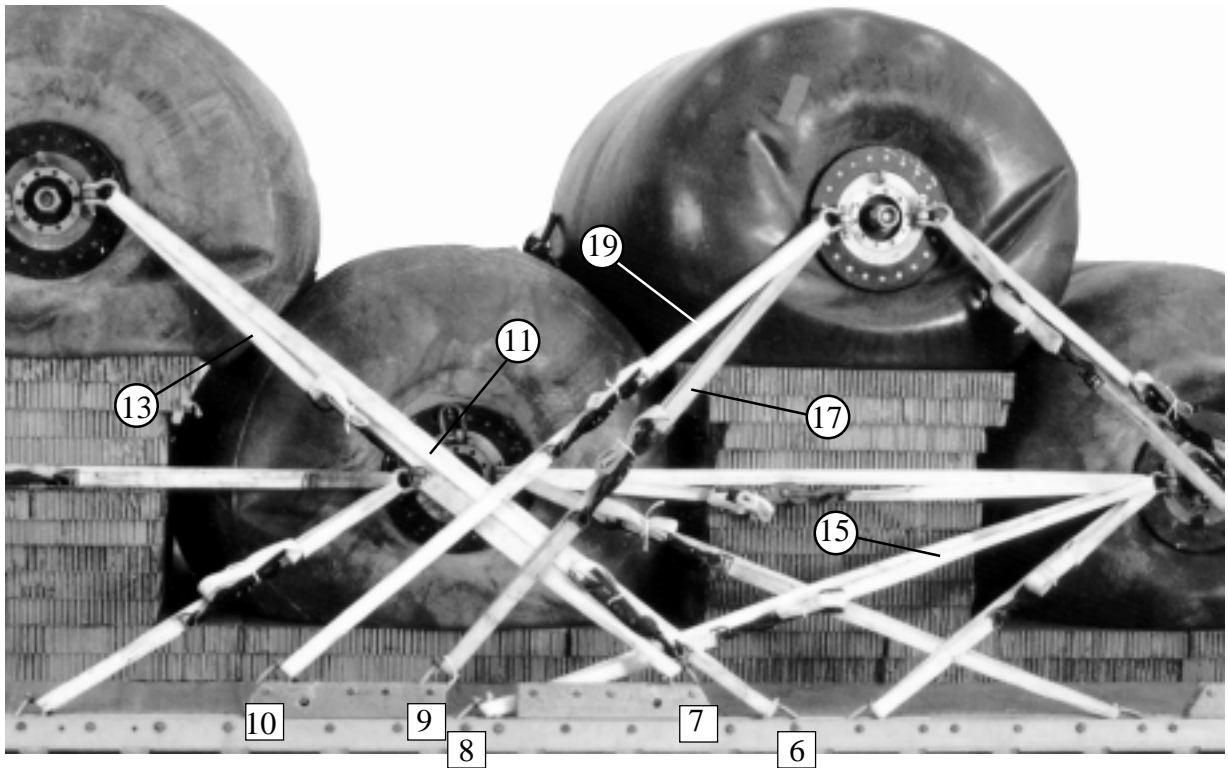

Lashing Number	Tie-down Clevis Number	Instructions
11	6	Pass lashing: Through right front shackle of fourth drum.
12	6A	Through left front shackle of fourth drum.
13	7	Through right front shackle of fourth drum.
14	7A	Through left front shackle of fourth drum.
15	8	Through right rear shackle of first drum.
16	8A	Through left rear shackle of first drum.
17	9	Through right rear shackle of second drum.
18	9A	Through left rear shackle of second drum.
19	10	Through right rear shackle of second drum.
20	10A	Through left rear shackle of second drum.

Figure 4-40. Fuel drums lashed to platform (continued)

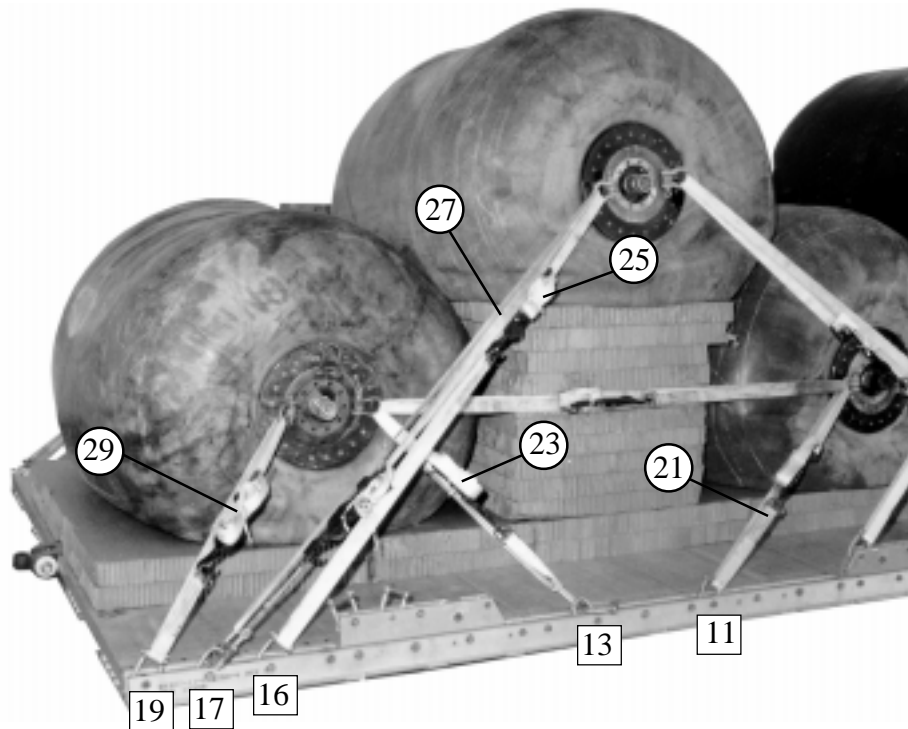

Lashing Number	Tie-down Clevis Number	Instructions
21	11	Pass lashing: Through right rear shackle of third drum.
22	11A	Through left rear shackle of third drum.
23	13	Through right front shackle of fifth drum.
24	13A	Through left front shackle of fifth drum.
25	16	Through right rear shackle of fourth drum.
26	16A	Through left rear shackle of fourth drum.
27	17	Through right rear shackle of fourth drum.
28	17A	Through left rear shackle of fourth drum.
29	19	Through right rear shackle of fifth drum.
30	19A	Through left rear shackle of fifth drum.

Figure 4-40. Fuel drums lashed to platform (continued)

4-63. Installing and Safetying Suspension Slings

Install the components of the centerline suspension system according to FM 10-500-2/TO 13C7-1-5, and as shown in Figure 4-41. Safety the suspension slings as shown in Figure 4-42.

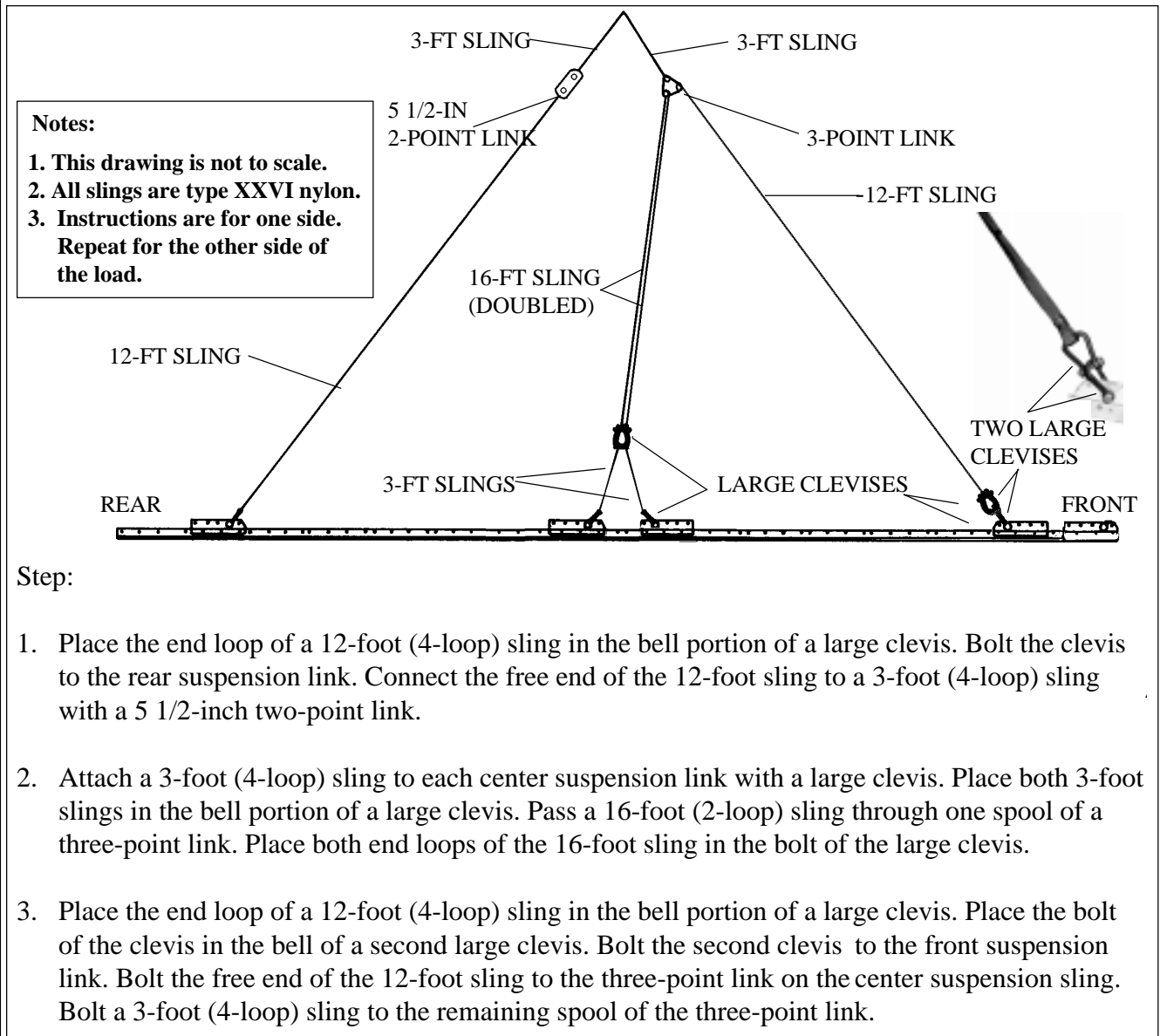
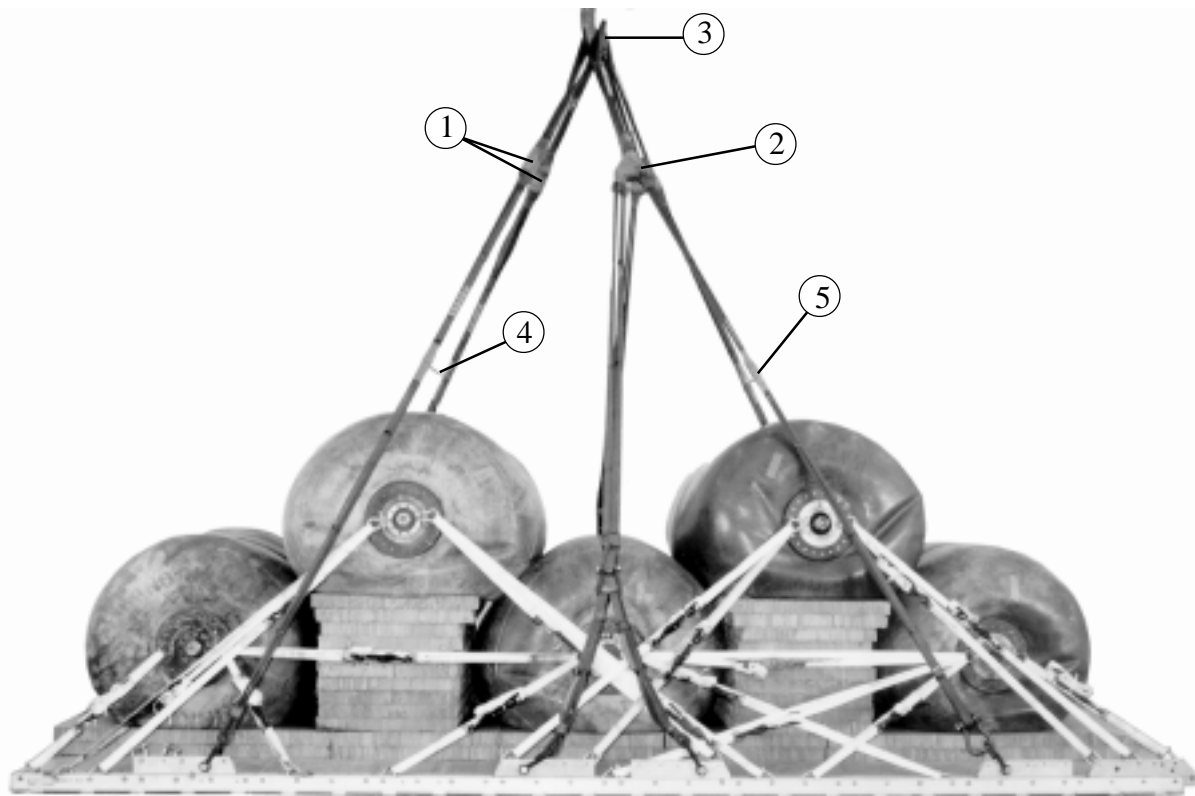

Figure 4-41. Suspension slings installed



- ① Pad the two-point links with felt taped in place.
- ② Pad the three-point links with felt taped in place.
- ③ Attach the 3-foot slings from the two- and three-point links to the crane hook. Raise the suspension slings.
- ④ Tie the rear suspension slings to each other 12 inches above the load with a double length of 1/2-inch tubular nylon webbing.
- ⑤ Tie the front suspension slings to each other in the same way.

Figure 4-42. Suspension slings safetied

4-64. Building and Lashing Parachute Stowage Platform

Build the parachute stowage platform and its supports as shown in Figure 4-43. Lash the parachute stowage platform to the load with four 15-foot lashings as shown in Figure 4-44.

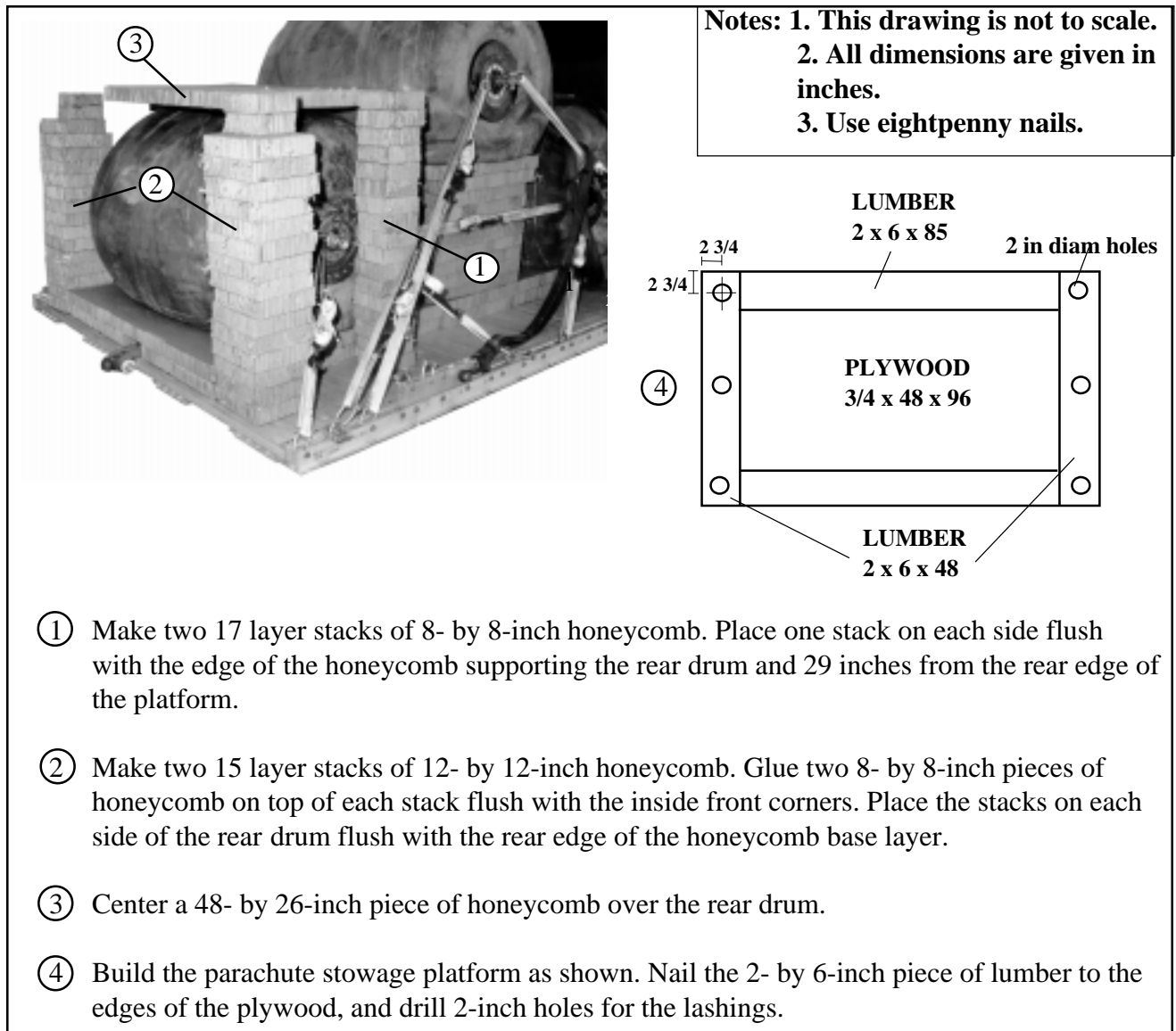
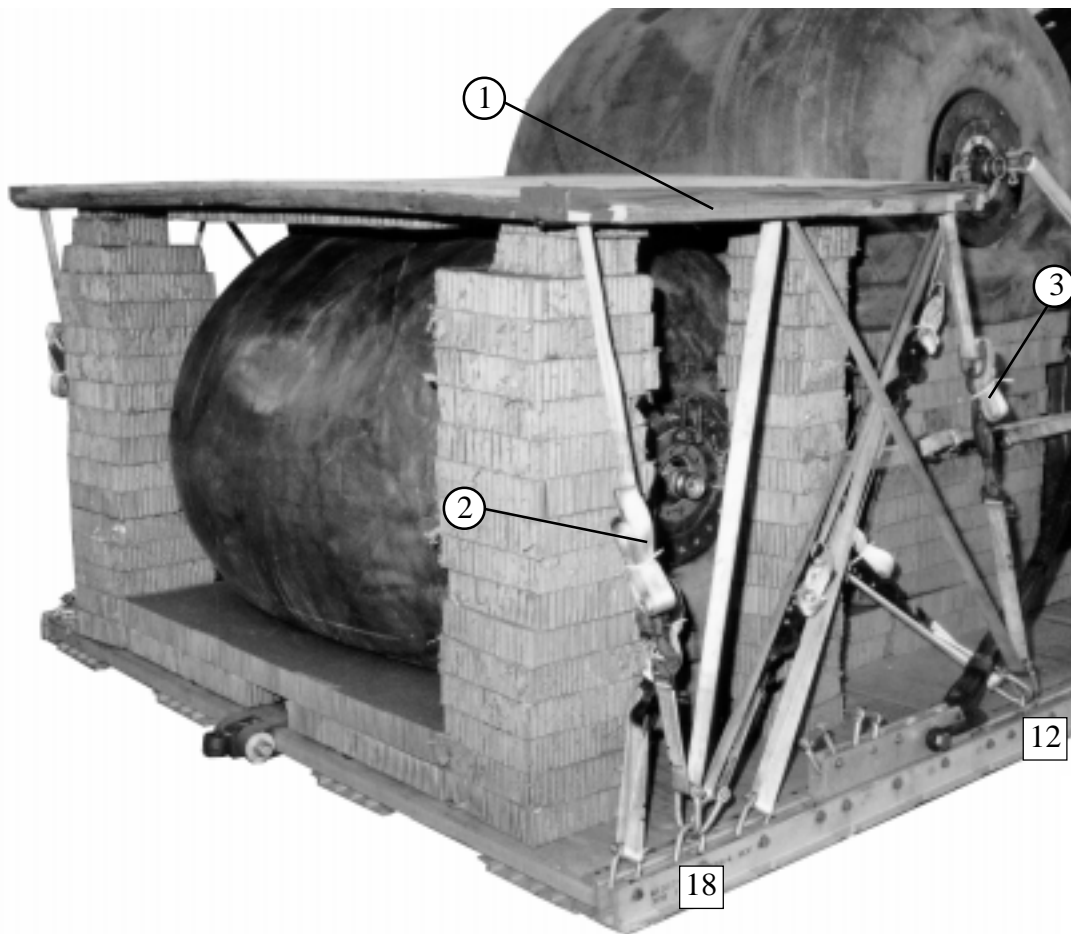

Figure 4-43. Supports placed and parachute stowage platform constructed



- ① Center the parachute stowage platform on the honeycomb placed in Figure 4-42.
- ② Lash the two rear holes in the parachute stowage platform to clevises 18 and 18A.
- ③ Lash the two front holes in the parachute stowage platform to clevises 12 and 12A.

Figure 4-44. Parachute stowage platform lashed to platform rails

4-65. Installing Cargo Parachutes

Install five G-11 cargo parachutes as shown in Figure 4-45, and according to FM 10-500-2/TO 13C7-1-5.

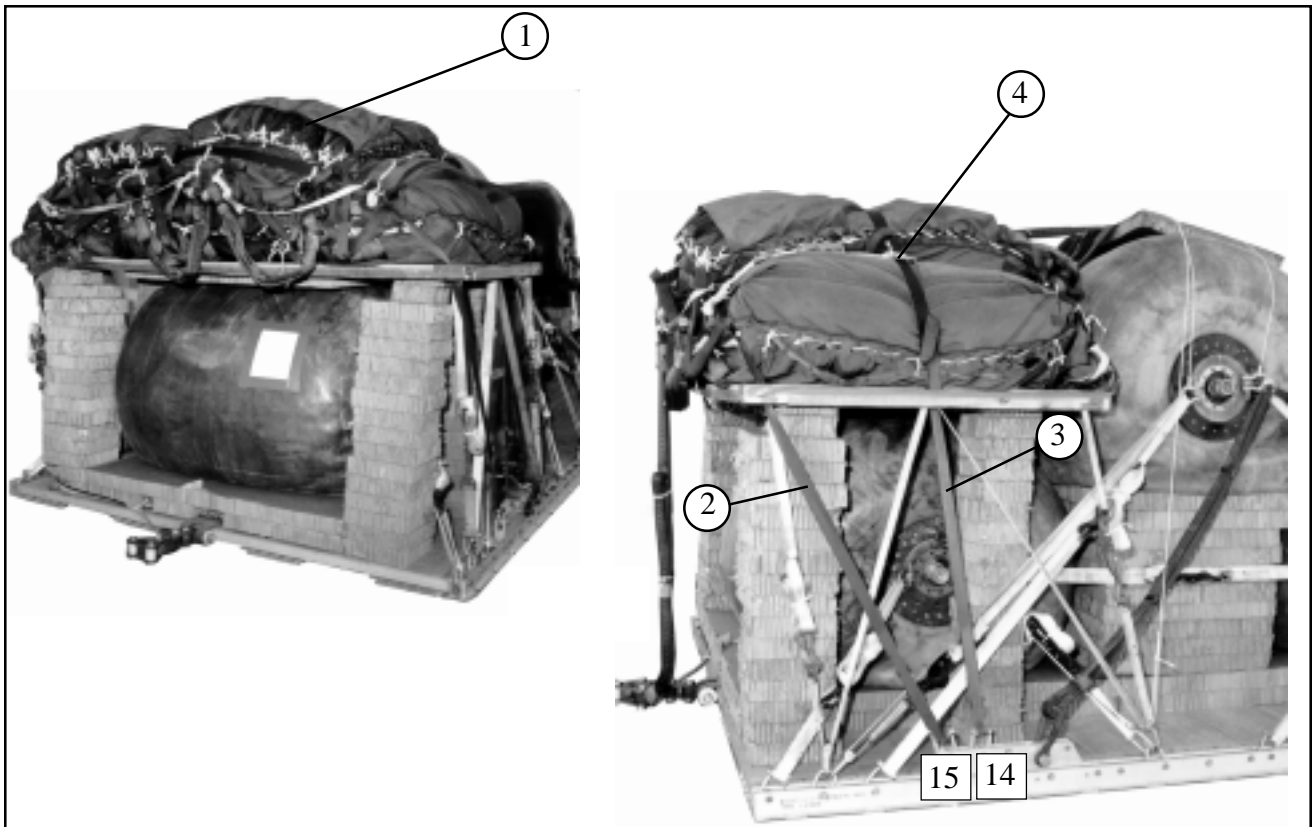

- ① Cluster five G-11 cargo parachutes on the parachute stowage platform.
- ② Pass the rear restraint strap through the rear holes in the parachute stowage platform, and tie the ends to clevises 15 and 15A.
- ③ Pass the front restraint strap through the center holes in the parachute stowage platform, and tie the ends to clevises 14 and 14A.
- ④ Install the parachute release knives according to FM 10-500-2/TO 13C7-1-5.

Figure 4-45. G-11 cargo parachutes installed

4-66. Installing Parachute Release

Prepare and install an M-2 cargo parachute release as shown in Figure 4-46 and according to FM 10-500-2/TO 13C7-1-5.

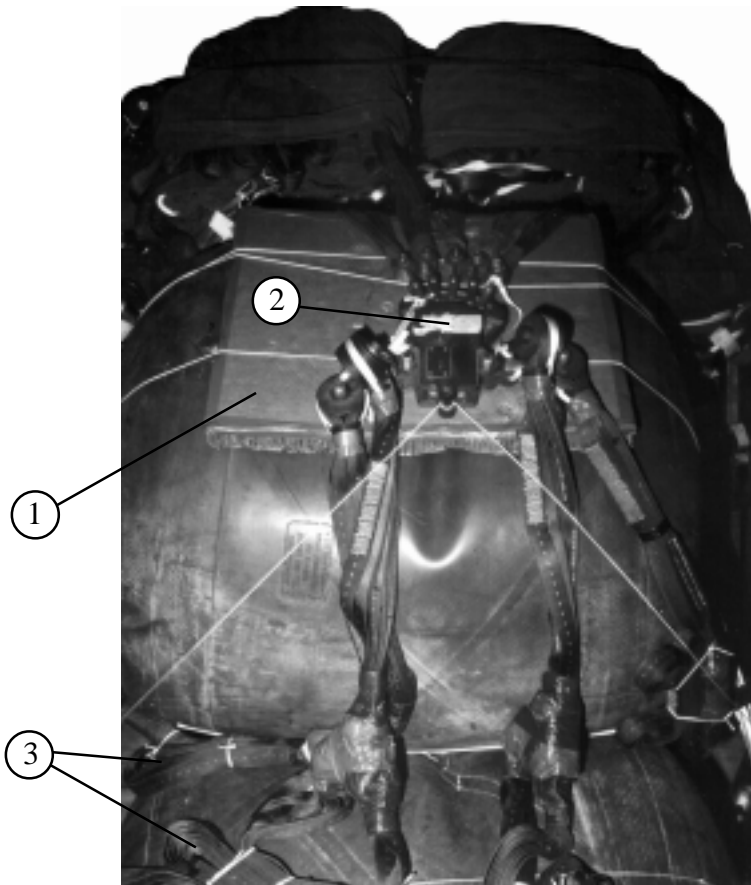

- ① Center a 36- by 36-inch piece of honeycomb over the fourth drum. Secure the honeycomb to the drum shackles with type III nylon cord.
- ② Attach the suspension slings and the riser extensions to the M-2 release according to FM 10-500-2/TO 13C7-1-5. Secure the release to the platform with type III nylon cord.
- ③ S-fold the suspension slings and tie the folds with type I, 1/4-inch cotton webbing.

Figure 4-46. M-2 release installed

4-67. Installing Extraction System

Prepare and install the EFTC extraction system as shown in Figure 4-47 and as shown in FM 10-500-2/TO 13C7-1-5.

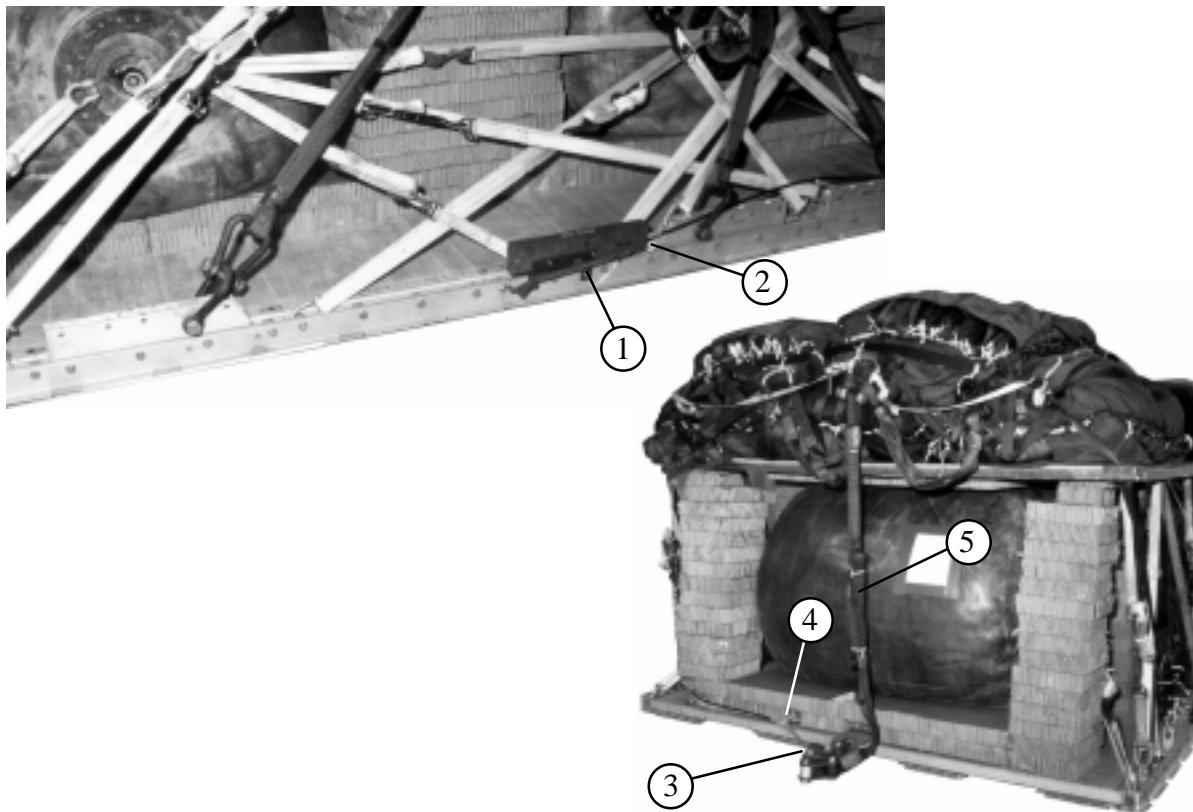

- ① Install the actuator mounting brackets to the rear holes on the left platform rail.
- ② Install a 20-foot cable to the actuator. Install the actuator to the brackets.
- ③ Attach the latch assembly to the extraction bracket. Attach the cable to the latch assembly.
- ④ Safety the cable to tiedown ring C10 with type I, 1/4-inch cotton webbing.
- ⑤ Install a 9-foot (2-loop), type XXVI nylon webbing sling as the deployment line. S-fold and tie the excess in two places with type I, 1/4-inch cotton webbing.

Figure 4-47. EFTC installed

4-68. Installing Provisions for Emergency Restraints

Select and install provisions for emergency restraints according to the emergency aft restraint requirements table in FM 10-500-2/TO 13C7-1-5.

4-69. Placing Extraction Parachute

Select the extraction parachute and extraction line needed using the extraction line requirements table in FM 10-500-2/TO 13C7-1-5. Place the extraction parachute and extraction line on the load for installation in the aircraft.

4-70. Marking Rigged Load

Mark the rigged load according to FM 10-500-2/TO 13C7-1-5 and as shown in Figure 4-48.

CAUTION

The load weight may vary from the one shown, depending upon the fuel rigged. Be sure that the load is weighed, and the parachute requirements, CB and tip-off curve recomputed.

4-71. Equipment Required

Use the equipment listed in Table 4-5 to rig this load.

CAUTION

Make the final rigger inspection required by FM 10-500-2/
TO 13C7-1-5 before the load leaves the rigging site.

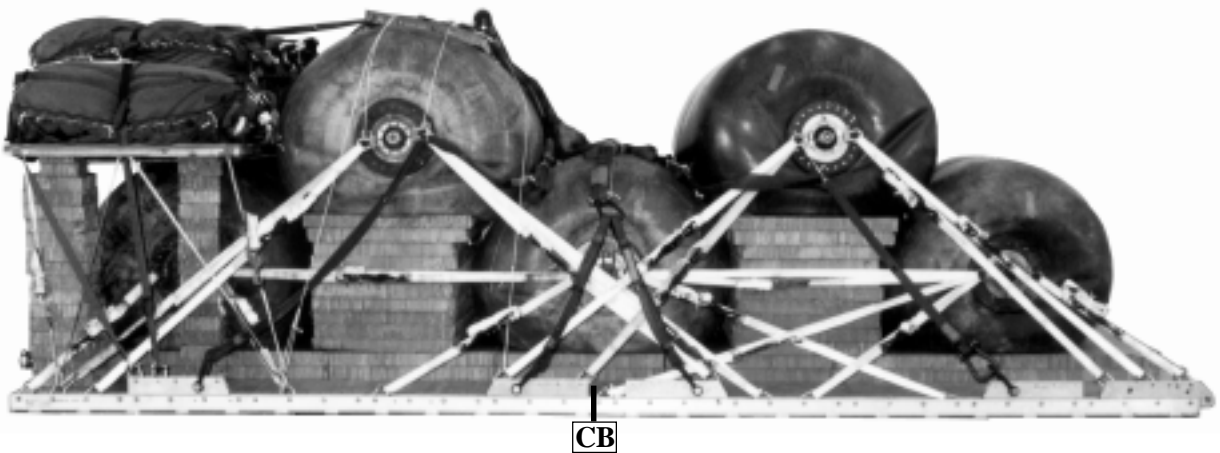
**Rigged Load Data**

Weight: Estimated, with gasoline	18,492 pounds
Maximum (as shown)	23,460 pounds
Height	84 3/4 inches
Width	108 inches
Length	240 inches
Overhang Front	5 inches
Rear	17 inches
CB (from front edge of platform)	126 inches
Extraction System (adds 18 inches to length of platform)	EFTC

Figure 4-48. Five drums rigged on a 20-foot, type V airdrop platform for low-velocity airdrop

Table 4-5. Equipment required for rigging five drums without pumping assembly on a 20-foot, type V airdrop platform for low-velocity airdrop.

National Stock Number	Item	Quantity
8040-00-273-8713	Adhesive, paste, 1-gal	As required
4030-00-678-8562	Clevis, suspension, 3/4-in (medium)	6
4030-00-090-5354	Clevis, suspension, 1-in (large)	16
4020-00-240-2146	Cord, nylon, type III, 550-lb	As required
1670-00-434-5787	Coupling, airdrop, extraction force transfer with cable, 20-ft	1
	Cover:	
1670-00-360-0328	Clevis, large	1
1670-00-360-0329	Link, type IV	6
8305-00-958-3685	Felt, 1/2-in thick	As required
1670-01-183-2678	Leaf, extraction line (line bag)	2
	Line, drogue (for C-17)	
1670-01-062-6316	60-ft (3-loop), type XXVI	1
	Line, extraction:	
1670-01-062-6316	60-ft (3-loop), type XXVI (for C-130)(Use w/ 140-ft for C-5)	1
1670-01-107-7651	140-ft (3-loop), type XXVI (for C-141B,C-5, or C-17)	1
	Link assembly:	
1670-00-783-5988	Type IV	6
1670-01-307-0155	Three-point	2
	Two-point:	
5306-00-435-8994	Bolt, 1-in diam, 4-in long	6
5310-00-232-5165	Nut, 1-in, hexagonal	6
1670-00-003-1954	Plate, side, 5 1/2-in	6
5365-00-007-3414	Spacer, large	6
5510-00-220-6148	Lumber, 2- by 6- by:	
	85-in	2
	48-in	2

Table 4-5. Equipment required for rigging five drums without pumping assembly on a 20-foot, type V airdrop platform for low-velocity airdrop (continued)

National Stock Number	Item	Quantity
5315-00-010-4659	Nail, steel wire, 8d	As required
1670-00-753-3928	Pad, energy-dissipating (honeycomb) 3- by 36- by 96-in	24 sheets
	Parachute:	
	Cargo:	
1670-01-016-7841	G-11C	5
	Cargo extraction:	
1670-00-040-8135	28-ft	1
	Drogue (for C-17)	
1670-01-063-3715	15-ft	1
	Platform, airdrop, type V, 20-ft	
1670-01-353-8425	Bracket assembly, coupling	(1)
1670-01-162-2372	Clevis assembly, type V	(42)
1670-01-162-2376	Extraction bracket assembly	(1)
1670-01-162-2381	Tandem link assembly (Multipurpose link)	(2)
1670-01-247-2389	Suspension link	(8)
5530-00-128-4981	Plywood, 3/4 -by 48- by 96-in	1 sheet
1670-01-097-8817	Release, cargo parachute, M-2	1
	Sling, cargo, airdrop	
	For suspension:	
1670-01-062-6306	3-ft (4-loop), type XXVI nylon webbing	8
1670-01-062-6307	12-ft (4-loop), type XXVI nylon webbing	4
1670-01-063-7761	16-ft (2-loop), type XXVI nylon webbing	2
	For lifting:	
1670-01-062-6304	9-ft (2-loop), type XXVI nylon webbing	2
	For deployment:	
1670-01-062-6304	9-ft (2-loop), type XXVI nylon webbing	1
	For riser extension:	
1670-01-062-6302	20-ft (2-loop), type XXVI nylon webbing	5
1670-01-062-6313	60-ft (3-loop), type XXVI nylon webbing	5

Table 4-5. Equipment required for rigging five drums without pumping assembly on a 20-foot, type V airdrop platform for low-velocity airdrop (continued)

National Stock Number	Item	Quantity
5340-00-040-8219	Strap, parachute release, multi-cut, comes w/ 3 knives	2
7510-00-266-5016	Tape, adhesive, 2-in	As required
1670-00-937-0271	Tie-down assembly, 15-foot	38
	Webbing:	
8305-00-268-2411	Cotton, 1/4-in, type I	As required
8305-00-082-5752	Nylon, tubular, 1/2-in	As required
8305-00-263-3591	Type VIII	As required

Section VI**RIGGING SIX DRUMS WITHOUT PUMPING ASSEMBLY
ON A 24-FOOT PLATFORM****4-72. Description of Load**

Six drums are rigged on a 24-foot, type V platform. Filled with 432 gallons of gasoline, each drum weighs 2,842 pounds and is 62 inches long and 53 inches in diameter. An empty drum weighs 250 pounds.

Note: Fill drums with no more than 432 gallons of fuel. If the drums are filled with a fuel other than gasoline, the drum weight must be computed.

4-73. Preparing Platform

Prepare a 24-foot, type V airdrop platform using two tandem links, eight suspension links and 46 clevises as shown in Figure 4-49.

Notes: 1. The nose bumper may or may not be installed.
2. Measurements given in this section are from the front edge of the platform, NOT from the front edge of the nose bumper.

WARNING

Do not add air to drums. Pressurization changes will cause leaking or bursting.

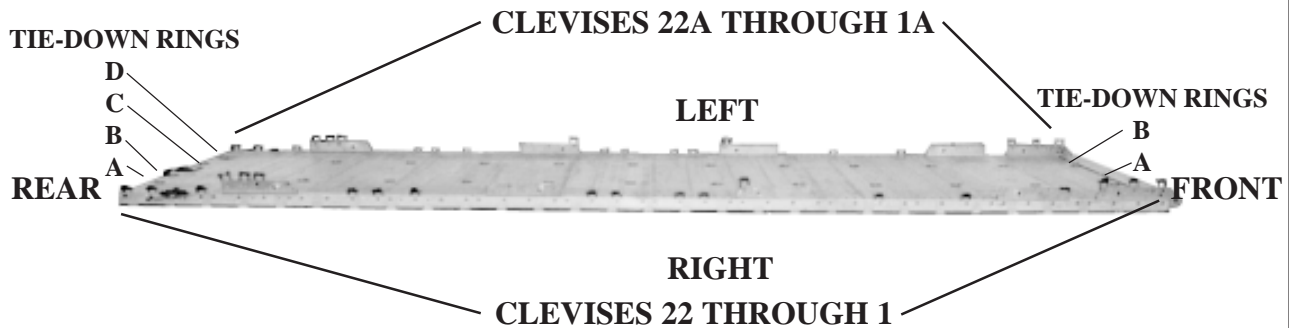

Step:

1. Inspect, or assemble and inspect, the platform as outlined in TM 10-1670-268-20&P/ TO 13C7-52-22.
2. Install suspension links on each platform side rail using holes 18, 19, and 20, and holes 6, 7, and 8.
3. Install a tandem link on the front of each platform side rail using holes 1, 2, and 3.
4. Install suspension links on each platform side rail using holes 29, 30, and 31, and holes 41, 42, and 43.
5. Bolt clevises on bushings 1, 3, and 4 of each front tandem link, on bushing 4 of each second suspension link, on bushing 1 of each third suspension link, and on bushings 2, 3 and 4 of each rear suspension link.
6. Install a clevis on bushing 46 in an inverted position on each platform side rail. Bolt two additional clevises to each inverted clevis.
7. Starting at the front of the platform, install clevises on each platform side rail using the bushings bolted on holes 10, 14, 22, 23, 26, 27, 35, 37, 38, 45, 47 and 48.
8. Starting at the front of the platform, number the clevises bolted to the right side 1 through 22, and those bolted to the left side 1A through 22A.
9. Label the tiedown rings according to FM 10-500-2/TO 13C7-1-5.

Figure 4-49. Platform prepared

4-74. Preparing and Positioning Honeycomb Stack

Prepare and position the honeycomb stack as shown in Figure 4-50.

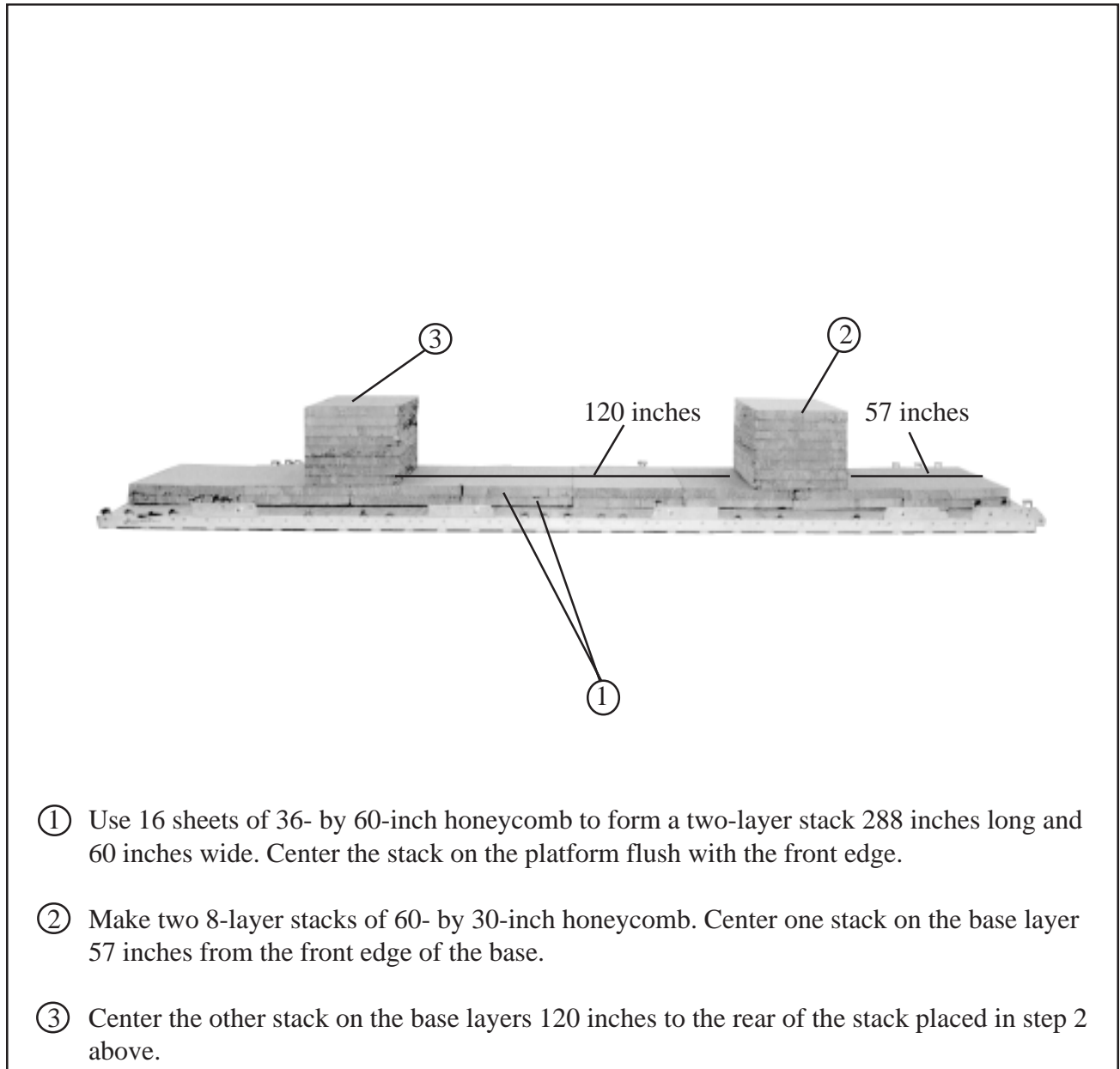
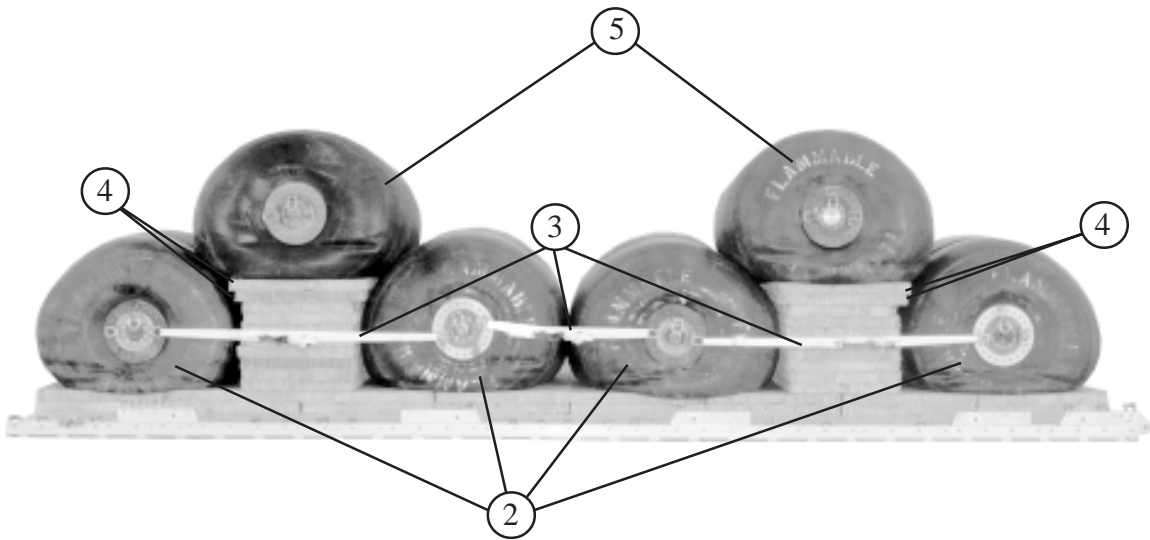

Figure 4-50. Honeycomb stack positioned

4-75. Installing Lifting Slings and Positioning Drums

Lift the drums and position them on the honeycomb as shown in Figure 4-51.



- ① Attach a 9-foot (2-loop), type XXVI nylon webbing sling to the upper shackle on each side of the drum with a platform clevis as shown in Figure 4-13.
- ② Lift four drums onto the honeycomb base as shown in Figure 4-13.
- ③ Lash the shackles of the drums together on each side with 15-foot tiedown assemblies.
- ④ Glue a 60- by 34-inch piece of honeycomb centered on each stack. Glue a 60- by 36-inch piece of honeycomb centered over the pieces placed previously.
- ⑤ Lift and position a drum onto each stack.

Figure 4-51. Fuel drums positioned

4-76. Lashing Drums

Use thirty-four 15-foot tiedown assemblies to lash the fuel drums as shown in Figure 4-52, and according to FM 10-500-2/TO 13C7-1-5.

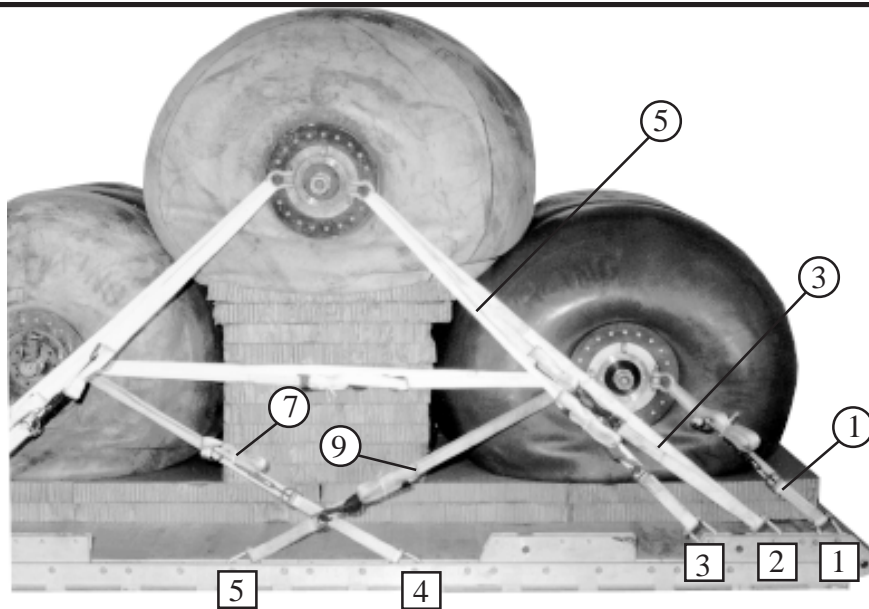

Lashing Number	Tie-down Clevis Number	Instructions
1	1	Pass lashing: Through right front shackle of first drum.
2	1A	Through left front shackle of first drum.
3	2	Through right front shackle of second drum.
4	2A	Through left front shackle of second drum.
5	3	Through right front shackle of second drum.
6	3A	Through left front shackle of second drum.
7	4	Through right front shackle of third drum.
8	4A	Through left front shackle of third drum.
9	5	Through right rear shackle of first drum.
10	5A	Through left rear shackle of first drum.

Figure 4-52. Fuel drums lashed to platform

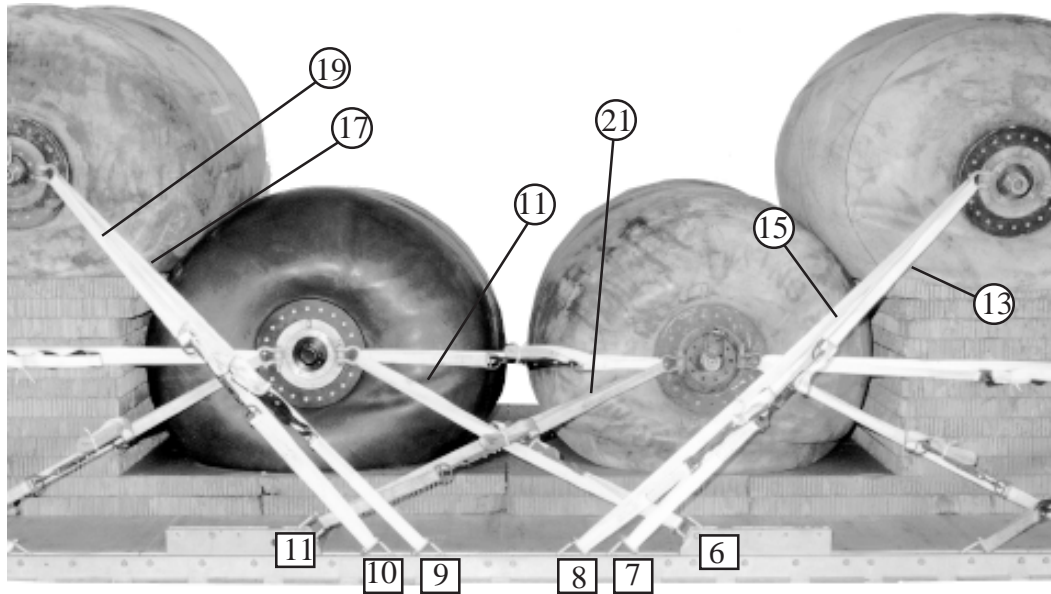

Lashing Number	Tie-down Clevis Number	Instructions
11	6	Pass lashing: Through right front shackle of fourth drum.
12	6A	Through left front shackle of fourth drum.
13	7	Through right rear shackle of second drum.
14	7A	Through left rear shackle of second drum.
15	8	Through right rear shackle of second drum.
16	8A	Through left rear shackle of second drum.
17	9	Through right front shackle of fifth drum.
18	9A	Through left front shackle of fifth drum.
19	10	Through right front shackle of fifth drum.
20	10A	Through left front shackle of fifth drum.
21	11	Through right rear shackle of third drum.
22	11A	Through left rear shackle of third drum.

Figure 4-52. Fuel drums lashed to platform (continued)

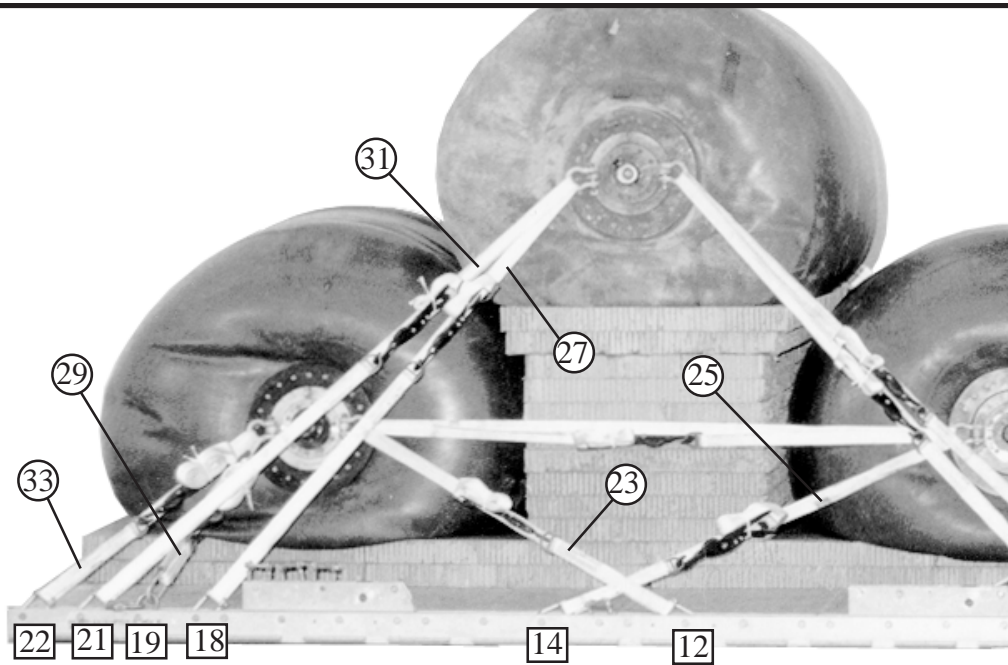

Lashing Number	Tie-down Clevis Number	Instructions
23	12	Pass lashing:
24	12A	Through right front shackle of sixth drum.
25	14	Through left front shackle of sixth drum.
26	14A	Through right rear shackle of fourth drum.
27	14A	Through left rear shackle of fourth drum.
28	18	Through right rear shackle of fifth drum.
29	18A	Through left rear shackle of fifth drum.
30	19	Through right rear shackle of sixth drum.
31	19A	Through left rear shackle of sixth drum.
32	21	Through right rear shackle of fifth drum.
33	21A	Through left rear shackle of fifth drum.
34	22	Through right rear shackle of sixth drum.
	22A	Through left rear shackle of sixth drum.

Figure 4-52. Fuel drums lashed to platform (continued)

4-77. Installing and Safetying Suspension Slings

Install the components of the centerline suspension system according to FM 10-500-2/TO 13C7-1-5, and as shown in Figure 4-53. Safety the suspension slings as shown in Figure 4-54.

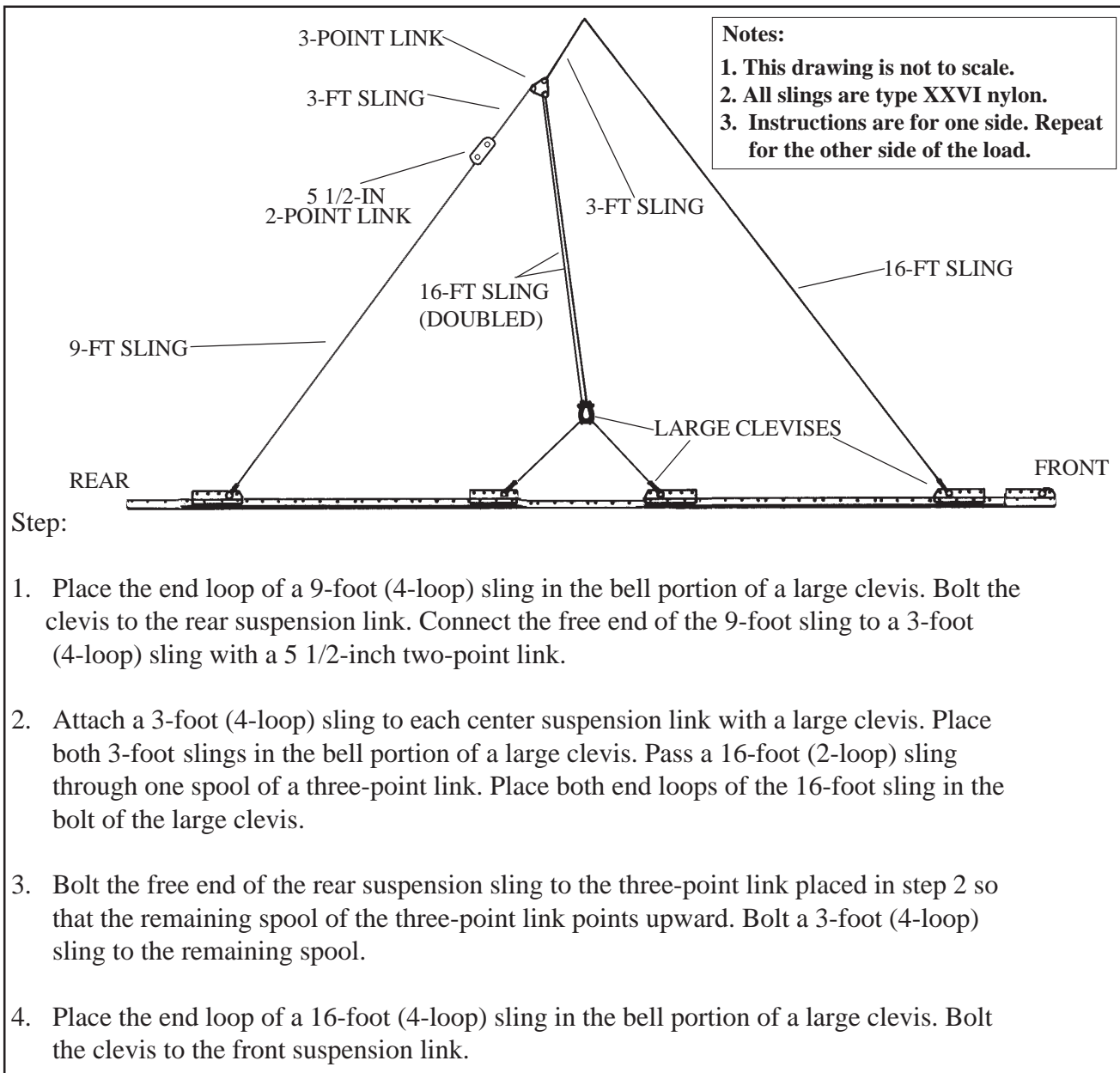
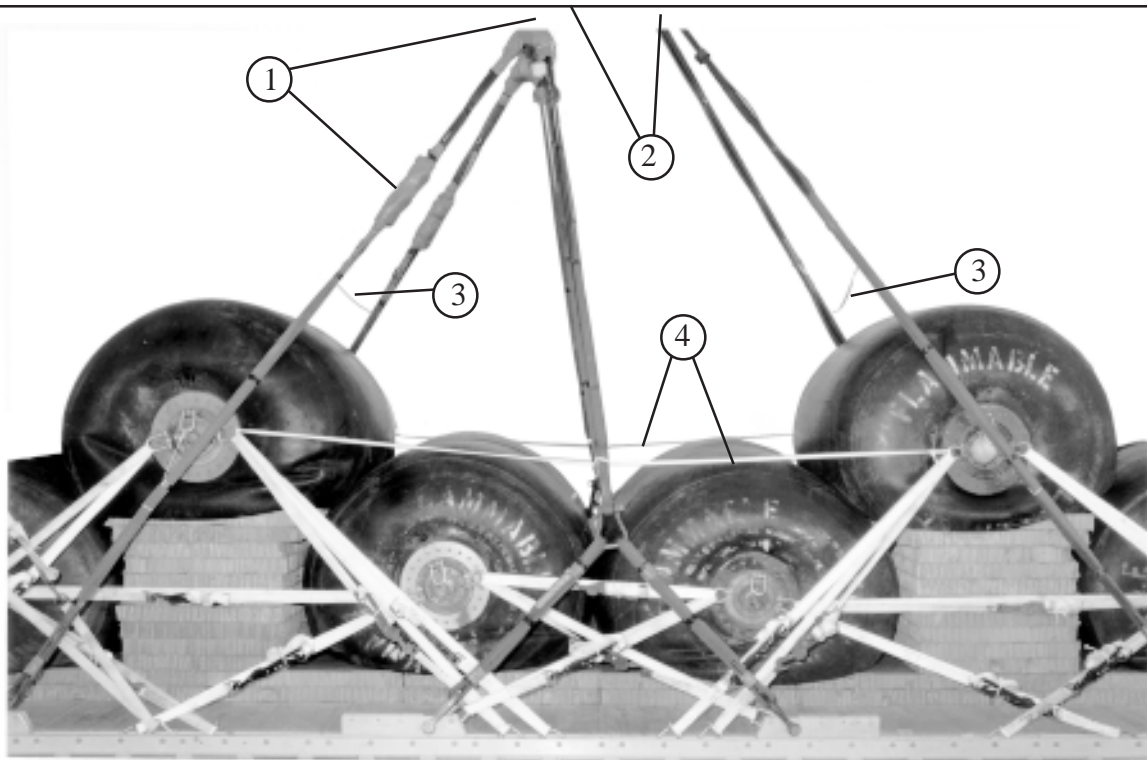
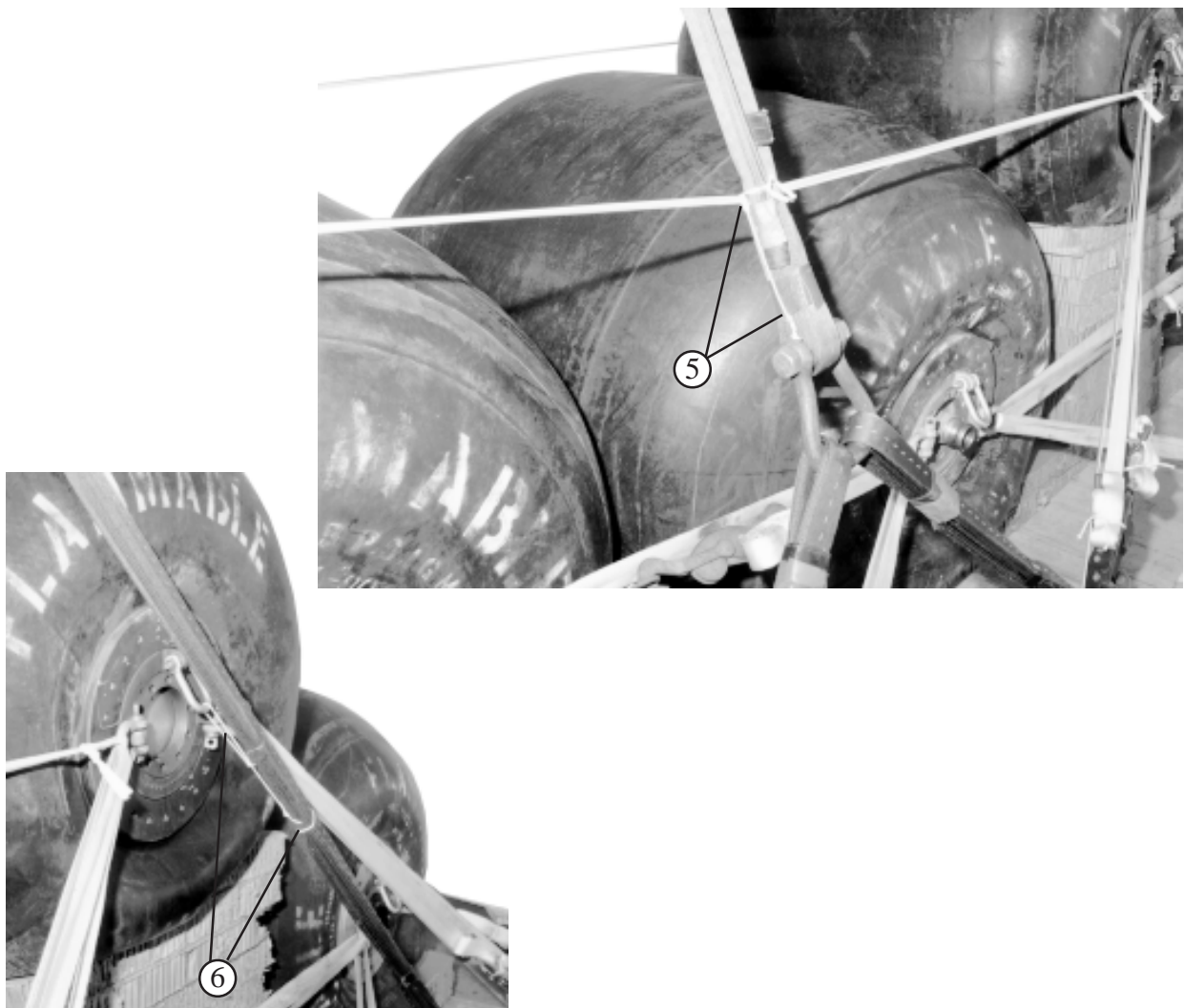

Figure 4-53. Suspension slings installed



- ① Pad the two-point links and the three-point links with felt taped in place.
- ② Attach the front suspension slings and the 3-foot slings from the three-point links to the crane hook. Raise the suspension slings.
- ③ Tie the rear suspension slings to each other 12 inches above the load with a double length of 1/2-inch tubular nylon webbing. Tie the front suspension slings to each other in the same way.
- ④ Tie a length of 1/2-inch tubular nylon webbing between the shackles of the second and fifth drums and under the center suspension slings. Make this tie as taut as possible.

Figure 4-54. Suspension slings safetied



- ⑤ Pass a length of 1/4-inch, type I cotton webbing through the plies of the center suspension slings at the clevis bolt. Pass the ends up and over the 1/2-inch tubular nylon webbing placed in step 4 so that the nylon webbing is kept in a horizontal position. Tie the cotton webbing to the outside of the slings.
- ⑥ Tie the front suspension slings to the upper shackle on the second drum with a length of type III nylon cord. Tie the rear suspension slings to the fifth drum in the same way.

Figure 4-54. Suspension slings safetied (continued)

4-78. Building and Lashing Parachute Stowage Platform

Build the parachute stowage platform and its supports as shown in Figure 4-55. Lash the parachute stowage platform to the load as shown in Figure 4-56.

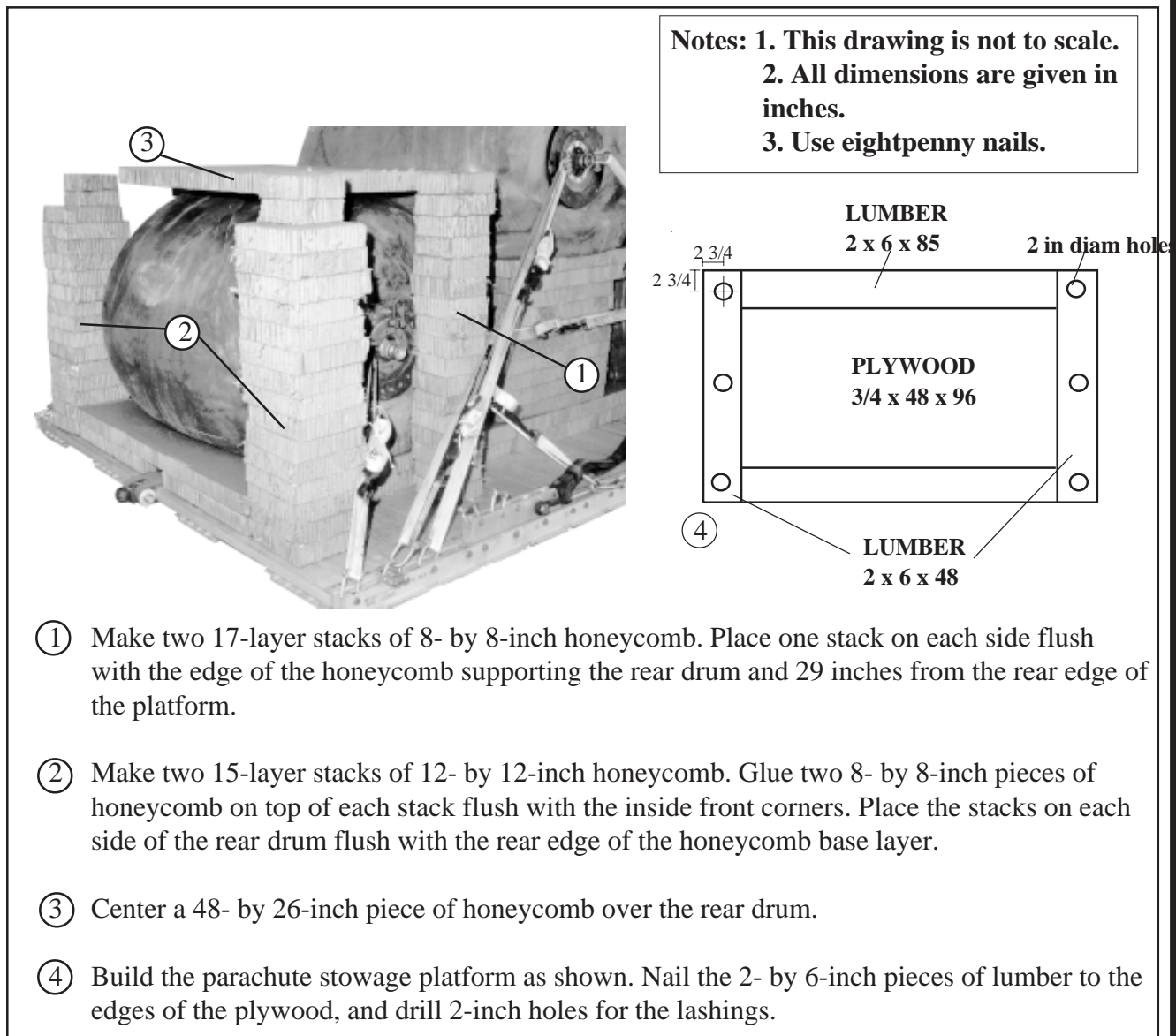
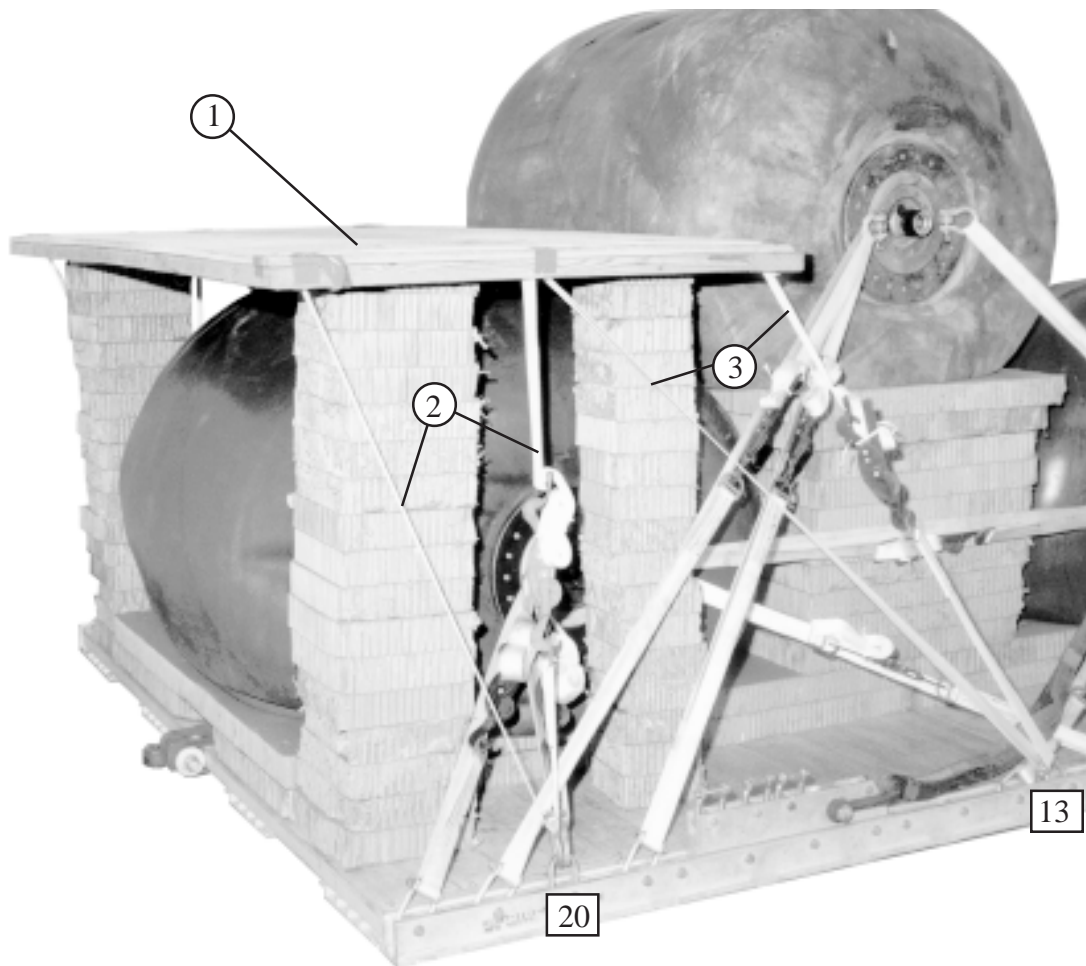

Figure 4-55. Supports placed and parachute stowage platform constructed



- ① Center the parachute stowage platform on the honeycomb placed in Figure 2-54.
- ② Lash the two rear holes in the parachute stowage platform to clevises 20 and 20A.
- ③ Lash the two front holes in the parachute stowage platform to clevises 13 and 13A.

Figure 4-56. Parachute stowage platform lashed to platform rails.

4-79. Installing Cargo Parachutes

Install six G-11 cargo parachutes as shown in Figure 4-57, and restrain them with type X nylon webbing according to FM 10-500-2/TO 13C7-1-5.

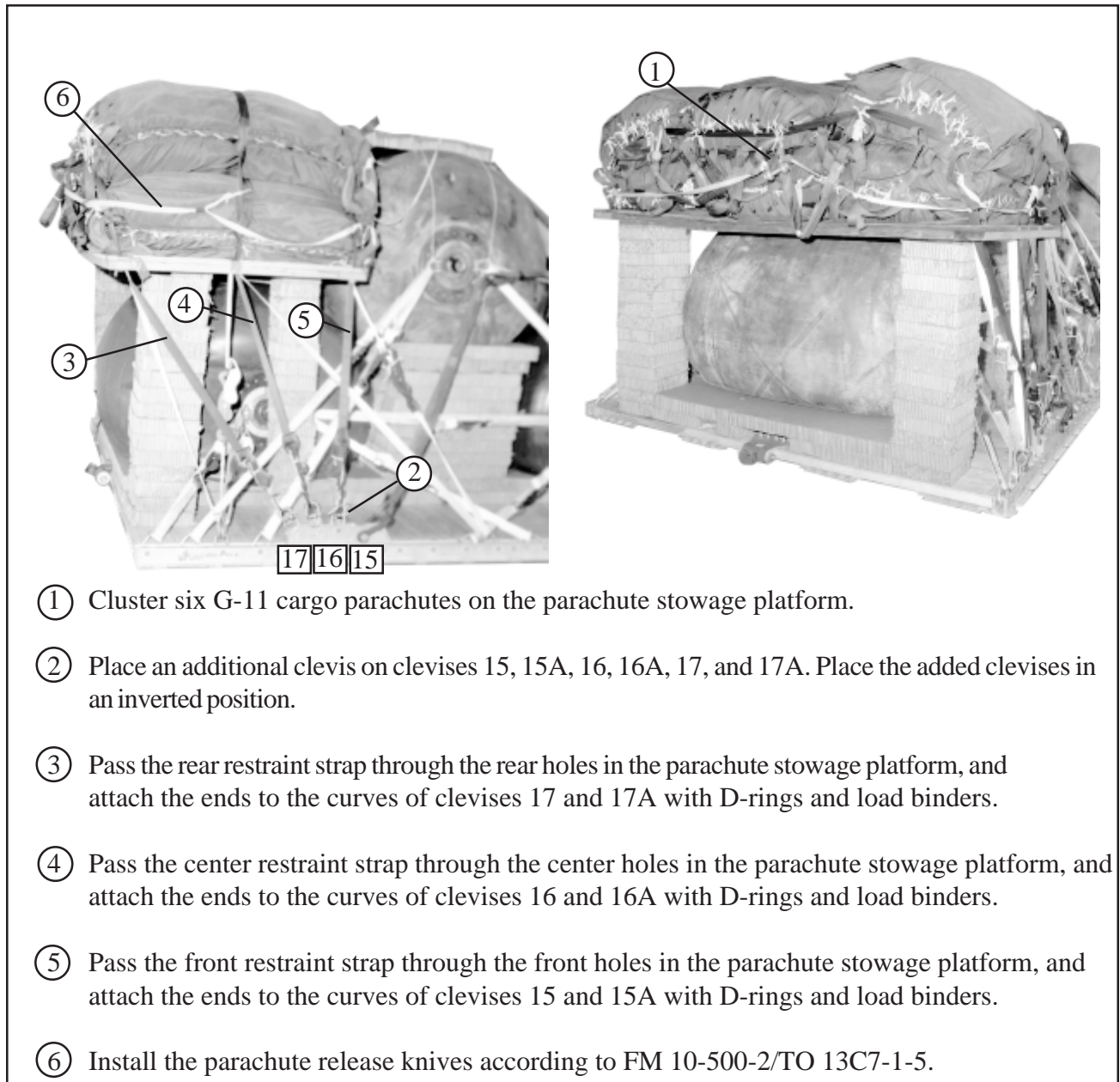

- ① Cluster six G-11 cargo parachutes on the parachute stowage platform.
- ② Place an additional clevis on clevises 15, 15A, 16, 16A, 17, and 17A. Place the added clevises in an inverted position.
- ③ Pass the rear restraint strap through the rear holes in the parachute stowage platform, and attach the ends to the curves of clevises 17 and 17A with D-rings and load binders.
- ④ Pass the center restraint strap through the center holes in the parachute stowage platform, and attach the ends to the curves of clevises 16 and 16A with D-rings and load binders.
- ⑤ Pass the front restraint strap through the front holes in the parachute stowage platform, and attach the ends to the curves of clevises 15 and 15A with D-rings and load binders.
- ⑥ Install the parachute release knives according to FM 10-500-2/TO 13C7-1-5.

Figure 4-57. G-11 cargo parachutes installed

4-80. Installing Parachute Release

Prepare and install an M-2 cargo parachute release as shown in Figure 4-58 and according to FM 10-500-2/TO 13C7-1-5.



- ① Center a 36- by 36-inch piece of honeycomb over the fifth drum. Secure the honeycomb to the drum shackles with type III nylon cord.
- ② Attach the suspension slings and the riser extensions to the M-2 release according to FM 10-500-2/TO 13C7-1-5. Secure the release to the platform with type III nylon cord.
- ③ S-fold the suspension slings and tie the folds with type I, 1/4-inch cotton webbing.

Figure 4-58. M-2 release installed

4-81. Installing Extraction System

Prepare and install the EFTC extraction system as shown in Figure 4-59 and as shown in FM 10-500-2/TO 13C7-1-5.

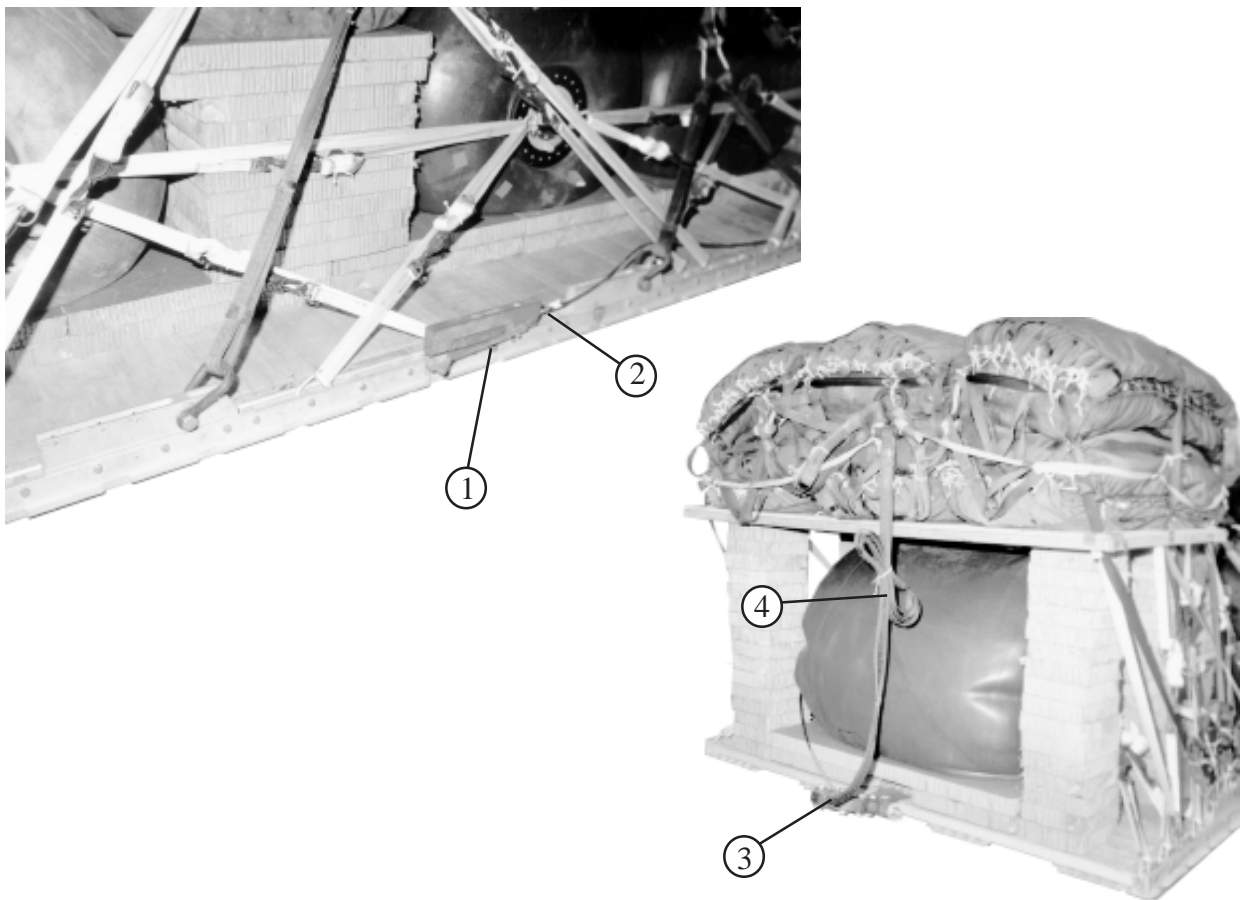

- ① Install the actuator mounting brackets to the rear holes on the left platform rail.
- ② Install a 24-foot cable to the actuator. Install the actuator to the brackets.
- ③ Attach the latch assembly to the extraction bracket. Attach the cable to the latch assembly.
- ④ Install a 9-foot (2-loop), type XXVI nylon webbing sling as the deployment line. S-fold and tie the excess in two places with type I, 1/4-inch cotton webbing.

Figure 4-59. EFTC installed

4-82. Installing Provisions for Emergency Restraints

Select and install provisions for emergency restraints according to the emergency aft restraint requirements table in FM 10-500-2/TO 13C7-1-5.

4-83. Placing Extraction Parachute

Select the extraction parachute and extraction line needed using the extraction line requirements table in FM 10-500-2/TO 13C7-1-5. Place the extraction parachute and extraction line on the load for installation in the aircraft.

4-84. Marking Rigged Load

Mark the rigged load according to FM 10-500-2/TO 13C7-1-5 and as shown in Figure 4-60.

CAUTION

The load weight may vary from the one shown, depending upon the fuel rigged. Be sure that the load is weighed, and the parachute requirements, CB, and tip-off curve recomputed.

4-85. Equipment Required

Use the equipment listed in Table 4-6 to rig this load.

CAUTION

Make the final rigger inspection required by FM 10-500-2/TO 13C7-1-5 before the load leaves the rigging site.

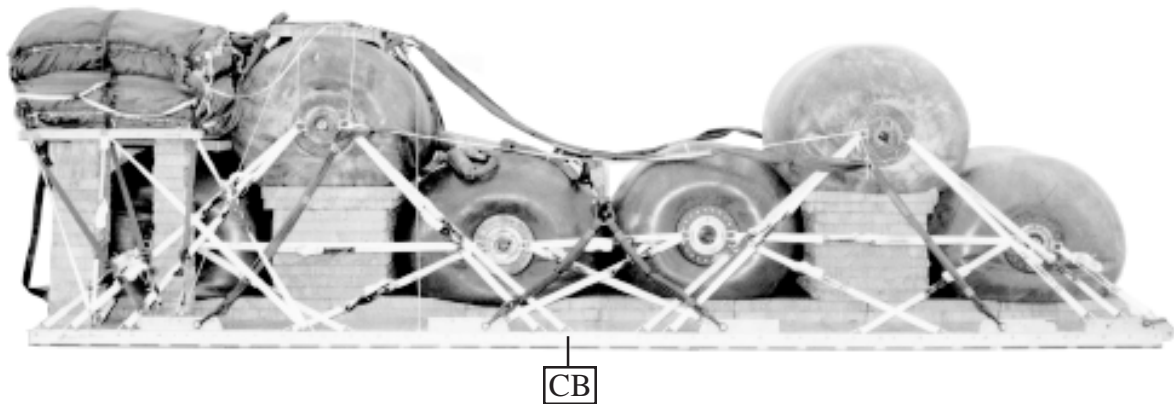
**Rigged Load Data**

Weight: Estimated, with gasoline	22,158 pounds
Maximum (as shown)	28,120 pounds
Height	85 inches
Width	108 inches
Length	288 inches
Overhang Front	5 inches
Rear	17 inches
CB (from front edge of platform)	153 inches
Extraction System (adds 18 inches to length of platform)	EFTC

Figure 4-60. Six drums rigged on a 24-foot, type V air drop platform for low-velocity airdrop

Table 4-6. Equipment required for rigging six drums without pumping assembly on a 24-foot, type V airdrop platform for low-velocity airdrop

National Stock Number	Item	Quantity
8040-00-273-8713	Adhesive, paste, 1-gal	As required
4030-00-678-8562	Clevis, suspension, 3/4-in (medium)	6
4030-00-090-5354	Clevis, suspension, 1-in (large)	14
4020-00-240-2146	Cord, nylon, type III, 550-lb	As required
1670-00-434-5782	Coupling, airdrop, extraction force transfer with cable, 24-ft	1
	Cover:	
1670-00-360-0328	Clevis, large	1
1670-00-360-0329	Link, type IV	7
8305-00-958-3685	Felt, 1/2-in thick	As required
1670-01-183-2678	Leaf, extraction line (line bag)	2
	Line, drogue (for C-17)	
1670-01-062-6316	60-ft (3-loop), type XXVI	1
	Line, extraction:	
1670-01-062-6316	60-ft (3-loop), type XXVI (for C-130)(Use w/ 140-ft for C-5)	1
1670-01-107-7651	140-ft (3-loop), type XXVI (for C-141B,C-5, or C-17)	1
	Link assembly:	
1670-01-307-0155	Three-point	2
1670-00-783-5988	Type IV	7
	Two-point:	
5306-00-435-8994	Bolt, 1-in diam, 4-in long	6
5310-00-232-5165	Nut, 1-in, hexagonal	6
1670-00-003-1954	Plate, side, 5 1/2-in	6
5365-00-007-3414	Spacer, large	6
5510-00-220-6148	Lumber: 2- by 6- by:	
	85-in	2
	48-in	2

Table 4-6. Equipment required for rigging six drums without pumping assembly on a 24-foot, type V airdrop platform for low-velocity airdrop (continued)

National Stock Number	Item	Quantity
5315-00-010-4659	Nail, steel wire, 8d	As required
1670-00-753-3928	Pad, energy-dissipating (honeycomb) 3- by 36- by 96-in	26 sheets
	Parachute:	
	Cargo:	
1670-01-016-7841	G-11C	6
	Cargo extraction:	
1670-00-040-8135	28-ft	1
	Drogue (for C-17)	
1670-01-063-3715	15-ft	1
	Platform, airdrop, type V, 24-ft	
1670-01-353-8425	Bracket assembly, coupling	(1)
1670-01-162-2372	Clevis assembly, type V	(48)
1670-01-162-2376	Extraction bracket assembly	(1)
1670-01-162-2381	Tandem link assembly (Multipurpose link)	(2)
1670-01-247-2389	Suspension link	(8)
5530-00-128-4981	Plywood, 3/4 -by 48- by 96-in	1 sheet
1670-01-097-8817	Release, cargo parachute, M-2	1
	Sling, cargo, airdrop	
	For suspension:	
1670-01-062-6306	3-ft (4-loop), type XXVI nylon webbing	8
1670-01-062-6305	9-ft (4-loop), type XXVI nylon webbing	2
1670-01-063-7761	16-ft (2-loop), type XXVI nylon webbing	4
	For lifting:	
1670-01-062-6304	9-ft (2-loop), type XXVI nylon webbing	2
	For deployment:	
1670-01-062-6304	9-ft (2-loop), type XXVI nylon webbing	1
	For riser extension:	
1670-01-062-6311	120-ft (2-loop), type XXVI nylon webbing	6

Table 4-6. Equipment required for rigging six drums without pumping assembly on a 24-foot, type V airdrop platform for low-velocity airdrop (continued)

National Stock Number	Item	Quantity
5340-00-040-8219	Strap, parachute release, multi-cut, comes w/ 3 knives	2
7510-00-266-5016	Tape, adhesive, 2-in	As required
1670-00-937-0271	Tie-down assembly, 15-foot	40
	Webbing:	
8305-00-268-2411	Cotton, 1/4-in, type I	As required
8305-00-082-5752	Nylon, tubular, 1/2-in	As required
8305-00-261-8584	Type X	As required

Section VII**RIGGING SIX DRUMS WITH PUMPING ASSEMBLY
ON A 24-FOOT PLATFORM****4-86. Description of Load**

Six drums are rigged with a pumping assembly on a 24-foot, type V platform. Filled with 432 gallons of gasoline, each drum weighs 2,842 pounds and is 62 inches long and 53 inches in diameter. An empty drum weighs 250 pounds.

Note: Fill drums with no more than 432 gallons of fuel. If the drums are filled with a fuel other than gasoline, the drum weight must be computed.

4-87. Preparing Platform

Prepare a 24-foot, type V airdrop platform using two tandem links, eight suspension links and 52 clevises as shown in Figure 4-61.

Notes: 1. The nose bumper may or may not be installed.
2. Measurements given in this section are from the front edge of the platform, NOT from the front edge of the nose bumper.

WARNING

Do not add air to drums. Pressurization changes will cause leaking or bursting.

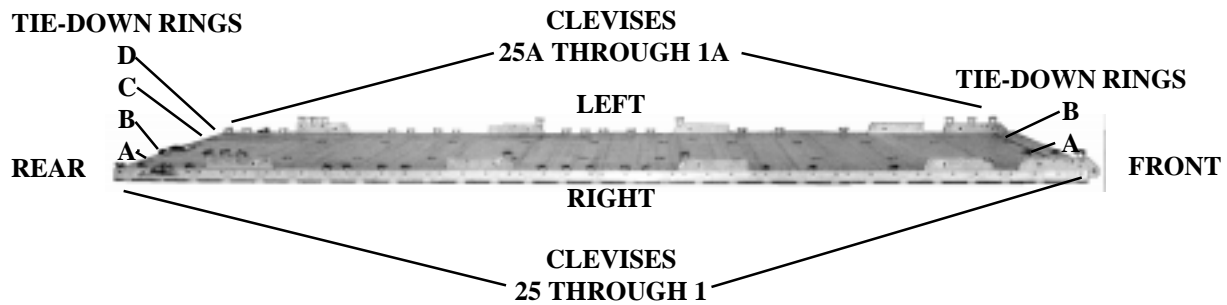

Step:

1. Inspect, or assemble and inspect, the platform as outlined in TM 10-1670-268-20&P/ TO 13C7-52-22.
2. Install suspension links on each platform side rail using holes 18, 19, and 20, and holes 6, 7, and 8.
3. Install a tandem link on the front of each platform side rail using holes 1, 2, and 3.
4. Install suspension links on each platform side rail using holes 29, 30, and 31, and holes 41, 42, and 43.
5. Bolt clevises on bushings 1, 3, and 4 of each front tandem link, on bushing 4 of each second suspension link, on bushing 1 of each third suspension link, and on bushings 2, 3 and 4 of each rear suspension link.
6. Install a clevis on bushing 46 in an inverted position on each platform side rail. Bolt two additional clevises to each inverted clevis.
7. Starting at the front of the platform, install clevises on each platform side rail using the bushings bolted on holes 10, 14, 16, 22, 23, 25, 26, 27, 34, 35, 37, 38, 45, 47 and 48.
8. Starting at the front of the platform, number the clevises bolted to the right side 1 through 25, and those bolted to the left side 1A through 25A.
9. Label the tie-down rings according to FM 10-500-2/TO 13C7-1-5.

Figure 4-61. Platform prepared

4-88. Preparing and Positioning Honeycomb Stacks

Prepare and position the honeycomb stack as shown in Figure 4-50 found in Section VI.

4-89. Installing Lifting Slings and Positioning Drums

Lift the drums and position them on the honeycomb as shown in Figure 4-51 found in Section VI.

4-90. Lashing Drums

Use fifty 15-foot tiedown assemblies to lash the fuel drums as shown in Figure 4-62, and according to FM 10-500-2/TO 13C7-1-5.

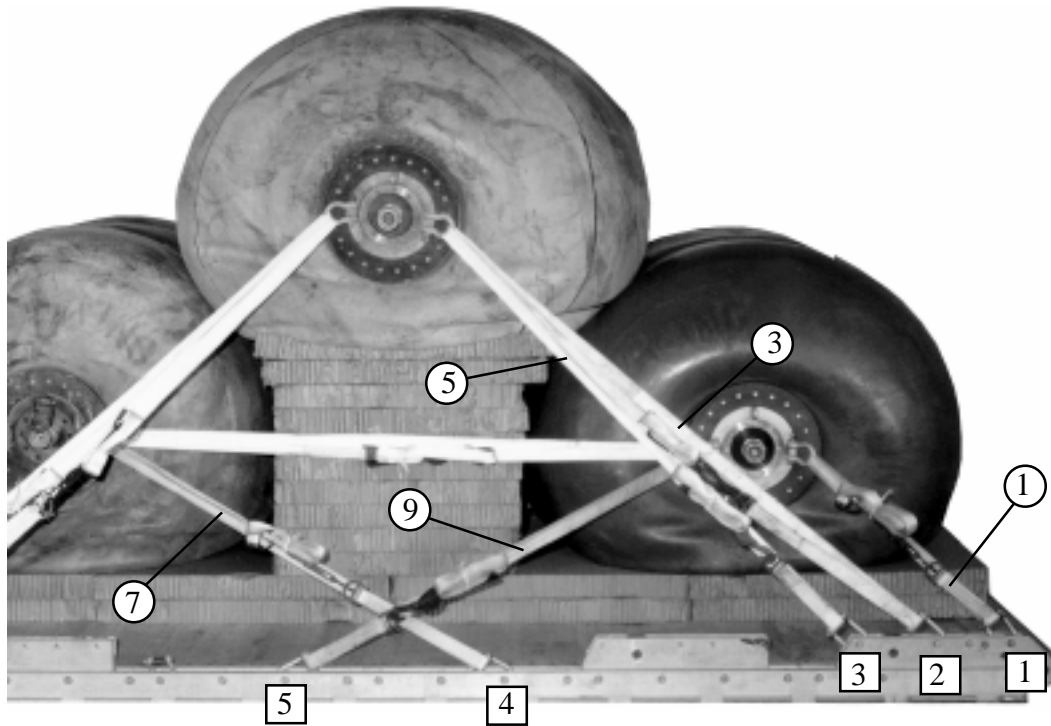

Lashing Number	Tie-down Clevis Number	Instructions
1	1	Pass lashing:
2	1A	Through right front shackle of first drum.
3	2	Through left front shackle of first drum.
4	2A	Through right front shackle of second drum.
5	3	Through left front shackle of second drum.
6	3A	Through right front shackle of second drum.
7	4	Through left front shackle of second drum.
8	4A	Through right front shackle of third drum.
9	5	Through left front shackle of third drum.
10	5A	Through right rear shackle of first drum.
		Through left rear shackle of first drum.

Figure 4-62. Fuel drums lashed to platform

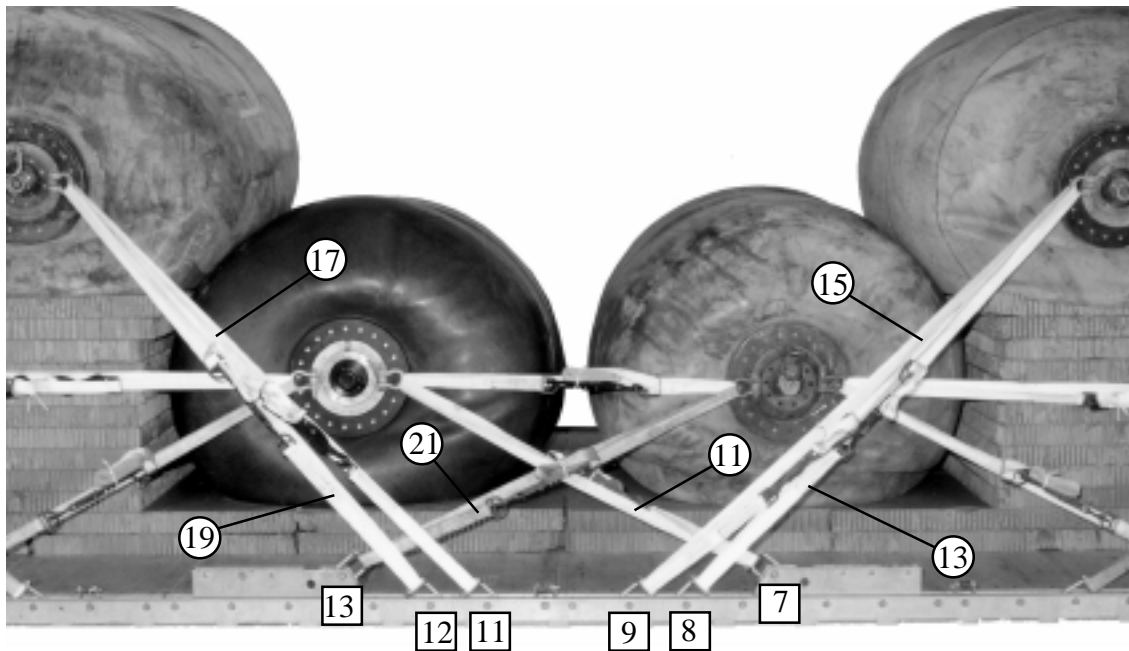

Lashing Number	Tie-down Clevis Number	Instructions
11	7	Pass lashing: Through right front shackle of fourth drum.
12	7A	Through left front shackle of fourth drum.
13	8	Through right rear shackle of second drum.
14	8A	Through left rear shackle of second drum.
15	9	Through right rear shackle of second drum.
16	9A	Through left rear shackle of second drum.
17	11	Through right front shackle of fifth drum.
18	11A	Through left front shackle of fifth drum.
19	12	Through right front shackle of fifth drum.
20	12A	Through left front shackle of fifth drum.
21	13	Through right rear shackle of third drum.
22	13A	Through left rear shackle of third drum.

Figure 4-62. Fuel drums lashed to platform (continued)

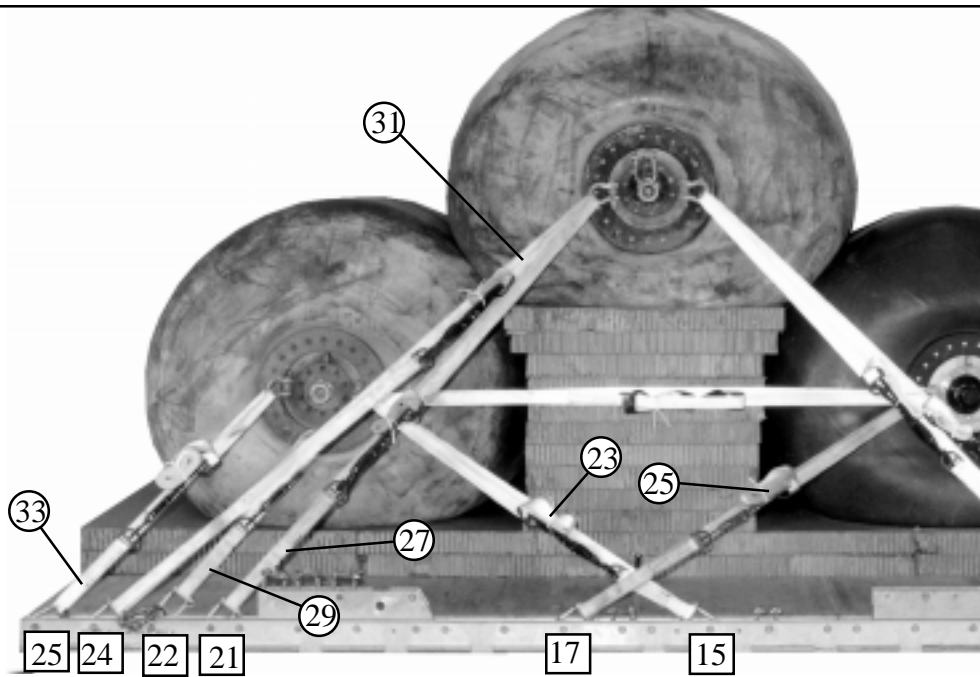

Lashing Number	Tie-down Clevis Number	Instructions
23	15	Pass lashing:
24	15A	Through right front shackle of sixth drum.
25	17	Through left front shackle of sixth drum.
26	17A	Through right rear shackle of fourth drum.
27	21	Through left rear shackle of fourth drum.
28	21A	Through right rear shackle of fifth drum.
29	22	Through left rear shackle of fifth drum.
30	22A	Through right front shackle of sixth drum.
31	24	Through left front shackle of sixth drum.
32	24A	Through right rear shackle of fifth drum.
33	25	Through left rear shackle of fifth drum.
34	25A	Through right rear shackle of sixth drum.
		Through left rear shackle of sixth drum.

Figure 4-62. Fuel drums lashed to platform (continued)

4-91. Preparing Pump Assembly

Build the box for the pump assembly as shown in Figure 4-63. Pack the pump assembly and hoses in the box as shown in Figure 4-64.

4-92. Lashing Pump Assembly to Platform

Place the pump assembly box on the load and lash it to the platform as shown in Figure 4-65.

Notes: 1. These drawings are not to scale.
2. Use 8d nails.
3. All dimensions are in inches.

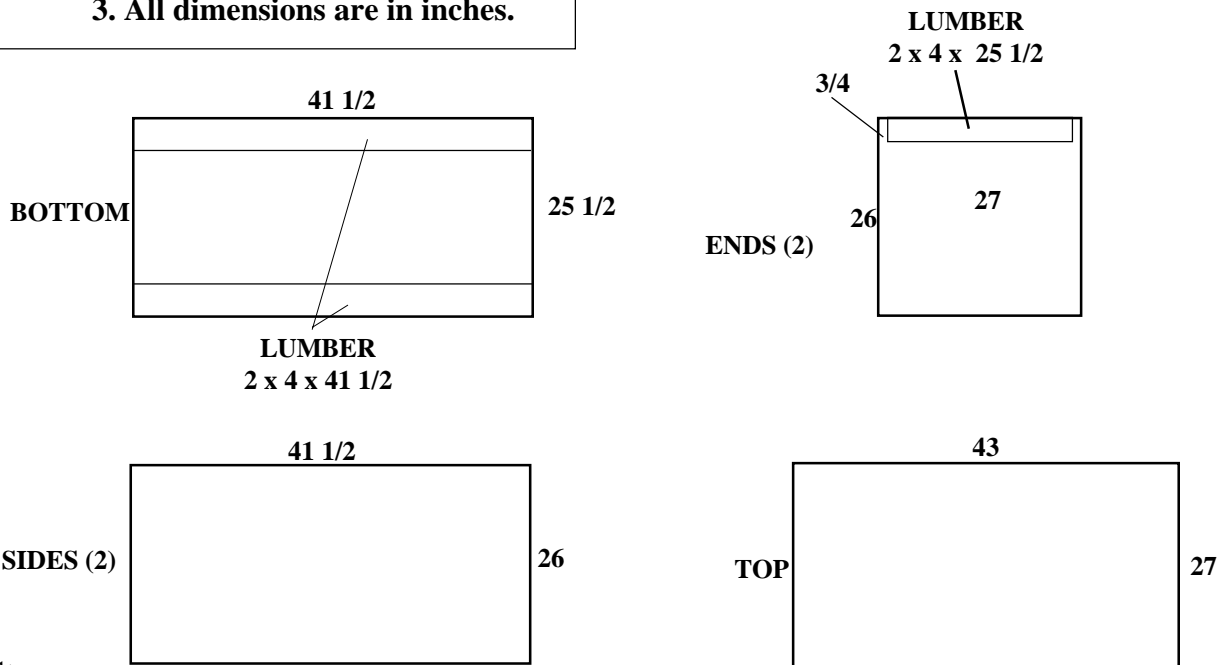

Step:

1. Cut the bottom of the box from 3/4-inch plywood 41 1/2 inches long and 25 1/2 inches wide. Nail a 41 1/2-inch length of 2- by 4-inch lumber flat side down and flush along each long edge of the bottom. The top of the box is 43- by 27 inches.
2. Cut the sides of the box from 3/4-inch plywood 41 1/2 inches long and 26 inches high. Place the sides flush with the bottom. Nail into the 2- by 4-inch pieces of lumber.
3. Cut the ends of the box from 3/4-inch plywood 27 inches wide and 26 inches high. Nail a piece of 2- by 4-inch lumber flat side down, centered, and flush with the top edge of each end piece. Nail the ends flush to the bottom and sides. Nail the sides to the 2- by 4-inch pieces of lumber on the ends.

Figure 4-63. Pump assembly box built

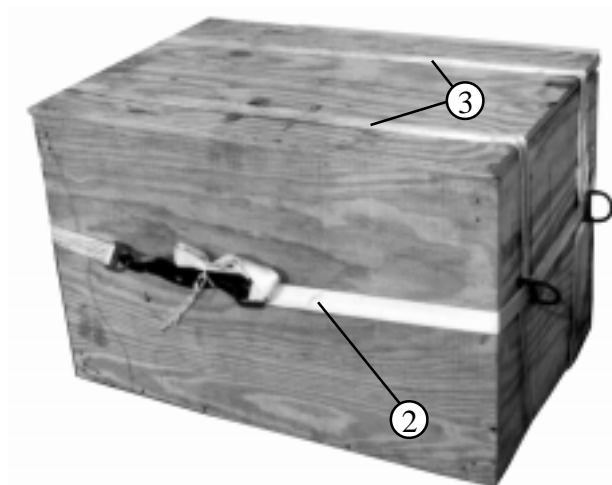
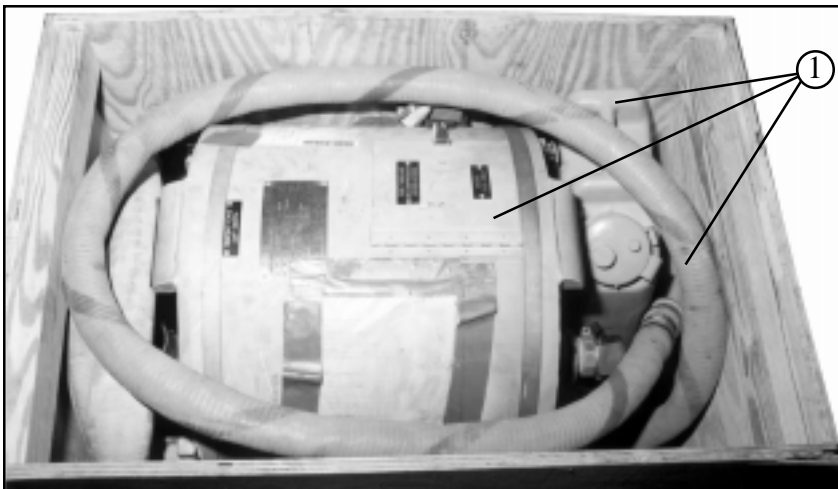

- ① Place the pump, its hoses, a five-gallon can of fuel, and any other items needed by the unit in the box. Pad the items with cellulose wadding. Nail the top to the box.
- ② Place four D-rings onto a 15-foot lashing. Place the lashing around the box lengthwise, and position two D-rings on each end of the box, six inches from each side. Tighten the lashing.
- ③ Pass two 15-foot lashings around the box and through the D-rings as shown. Tighten the lashings.

Figure 4-64. Pump assembly box packed

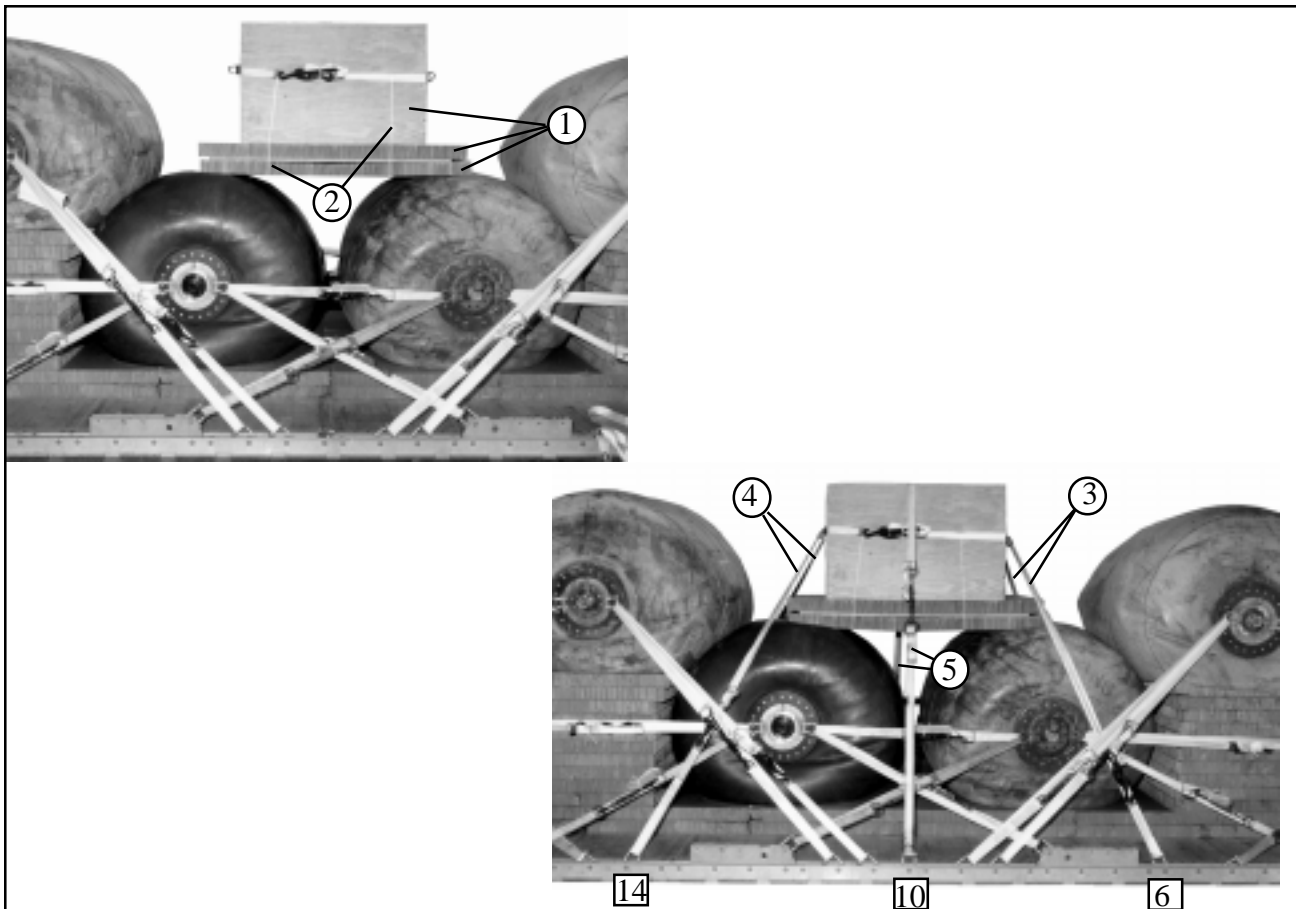

- ① Center and glue a 56- by 36-inch piece of 3/4-inch plywood between two 60 -by 36-inch pieces of honeycomb. Place the honeycomb and plywood centered over the third and fourth drums. Place the box centered on the honeycomb and plywood.
- ② Secure the box lashings to the honeycomb with type III nylon cord.
- ③ Lash the right front D-ring on the box to clevis 6. Lash the left front D-ring to clevis 6A.
- ④ Lash the right rear D-ring on the box to clevis 14. Lash the left rear D-ring to clevis 14A.
- ⑤ Pass lashings through clevises 10 and 10A and through their own D-rings. Secure the lashings together on one side of the load with two D-rings and a load binder.

Figure 4-65. Pump assembly box lashed to platform

4-93. Installing and Safetying Suspension Slings

Install the components of the centerline suspension sling system according to FM 10-500-2/TO 13C7-1-5, and as shown in Figure 4-43 found in Section VI. Safety the suspension slings as shown in Figure 4-54 found in Section VI.

4-94. Building and Lashing Parachute Stowage Platform

Build the parachute stowage platform and its supports as shown in Figure 4-55. Lash the parachute stowage platform to the load as shown in Figure 4-66.

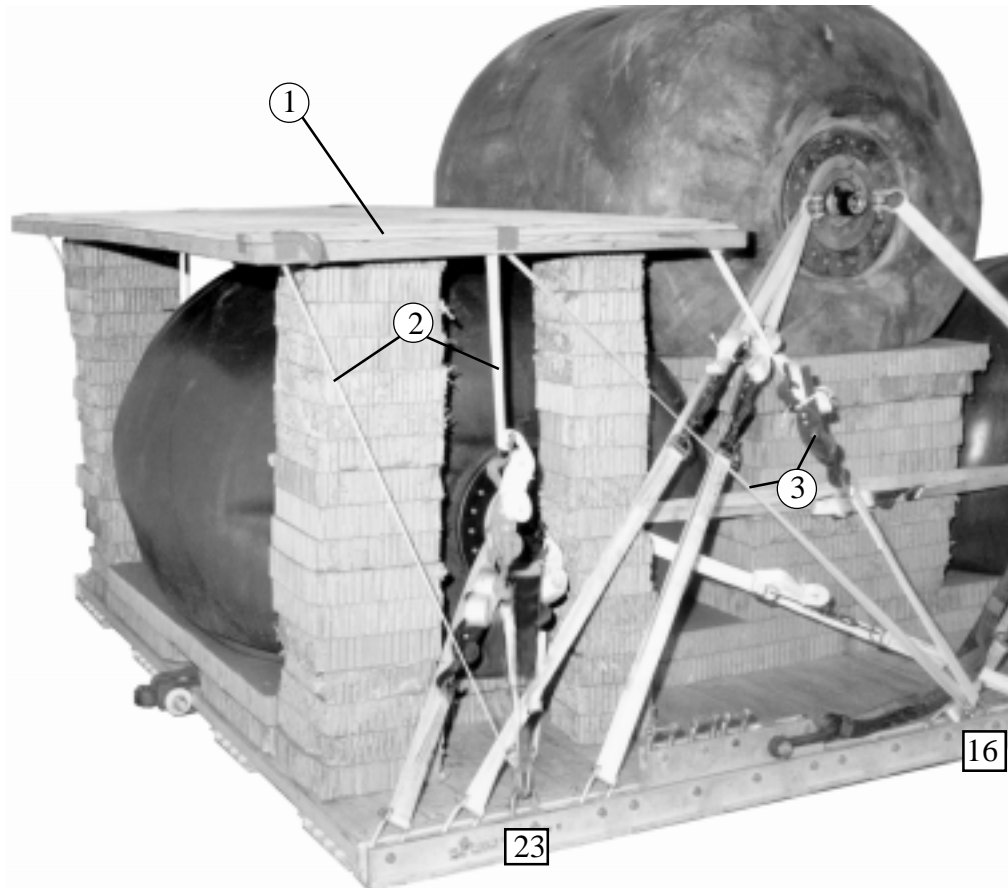

- ① Center the parachute stowage platform on the honeycomb placed in Figure 4-55. Rest the front edge of the platform against the fifth drum.
- ② Lash the two rear holes in the platform to clevises 23 and 23A.
- ③ Lash the two front holes in the platform to clevises 16 and 16A.

Figure 4-66. Parachute stowage platform lashed to platform rails

4-95. Installing Cargo Parachutes

Install six G-11 cargo parachutes as shown in Figure 4-67, and according to FM 10-500-2/TO 13C7-1-5.

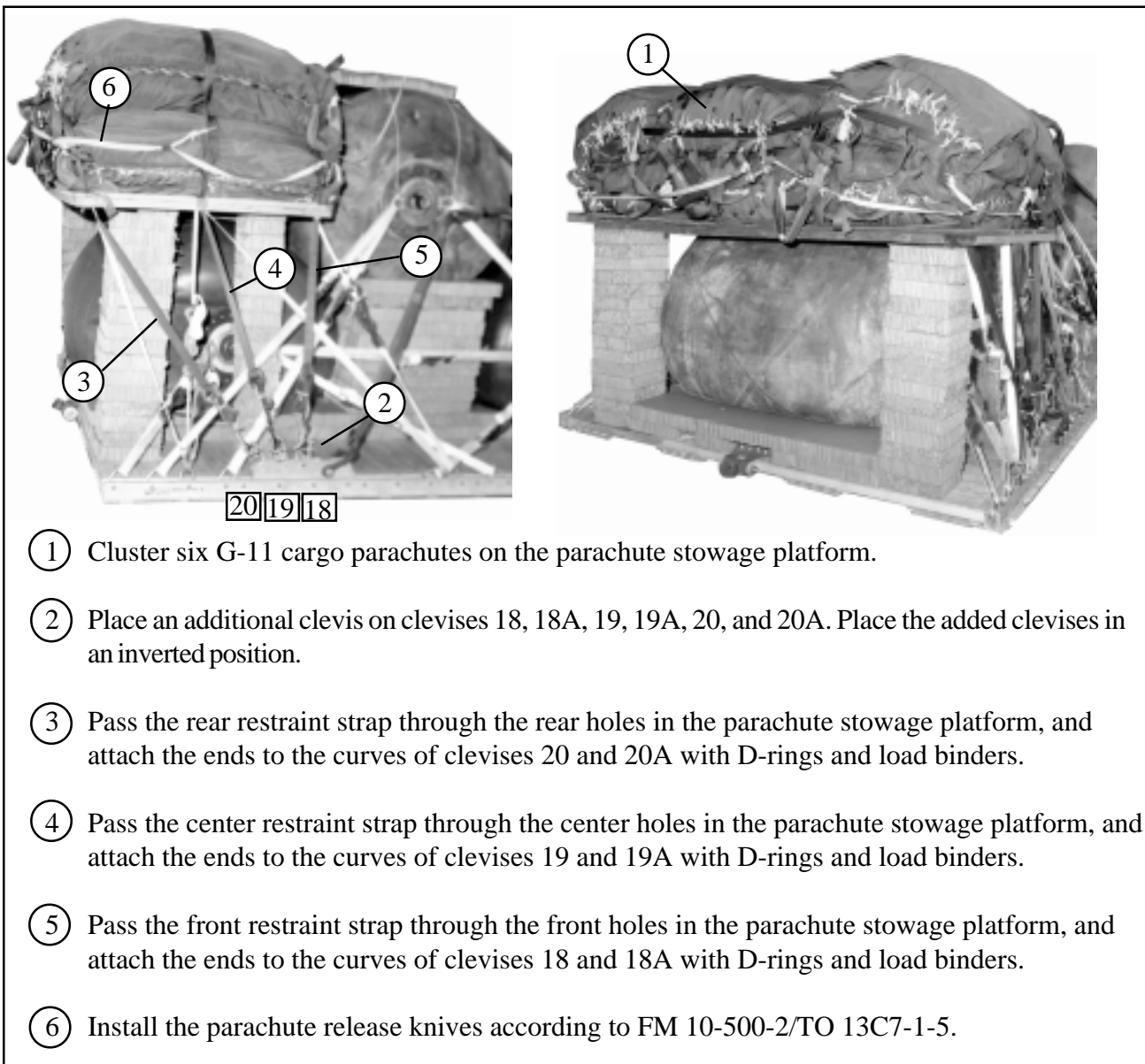
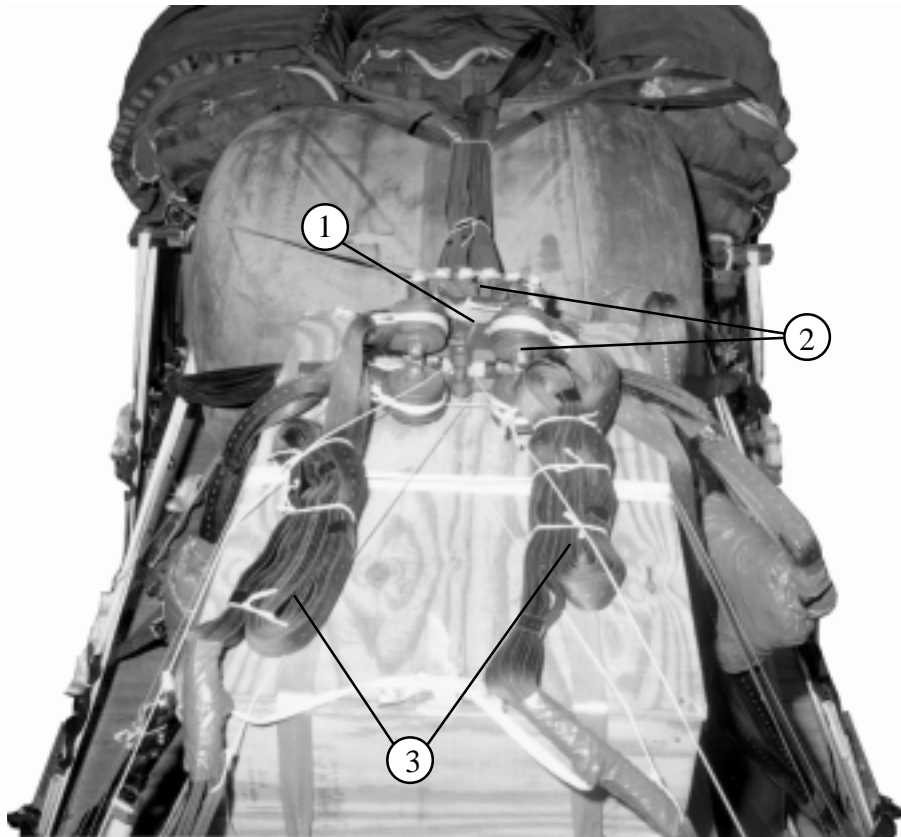

Figure 4-67. G-11 cargo parachutes installed

4-96. Installing Parachute Release

Prepare and install an M-2 cargo parachute release as shown in Figure 4-48, and according to FM 10-500-2/TO 13C7-1-5.



- ① Center the M-2 release assembly over the rear half of the pump box. Secure the release to the load with type III nylon cord.
- ② Attach the suspension slings and the riser extensions to the M-2 release according to FM 10-500-2/TO 13C7-1-5.
- ③ S-fold the suspension slings and tie the folds with type I, 1/4-inch cotton webbing.

Figure 4-68. M-2 release installed

4-97. Installing Extraction System

Prepare and install the EFTC extraction system as shown in Figure 4-59 found in Section VI, and according to FM 10-500-2/TO 13C7-1-5.

4-98. Installing Provisions for Emergency Restraints

Select and install provisions for emergency restraints according to the emergency aft restraint requirements table in FM 10-500-2/TO 13C7-1-5.

4-99. Placing Extraction Parachute

Select the extraction parachute and extraction line needed using the extraction line requirements table in FM 10-500-2/TO 13C7-1-5. Place the extraction parachute and extraction line on the load for installation in the aircraft.

4-100. Marking Rigged Load

Mark the rigged load according to FM 10-500-2/TO 13C7-1-5 and as shown in Figure 4-69.

CAUTION

The load weight may vary from the one shown, depending upon the fuel rigged. Be sure that the load is weighed, and the parachute requirements, CB, and tip-off curve recomputed.

4-101. Equipment Required

Use the equipment listed in Table 4-7 to rig this load.

CAUTION

**Make the final rigger inspection required by FM 10-500-2/TO 13C7-1-5
before the load leaves the rigging site.**

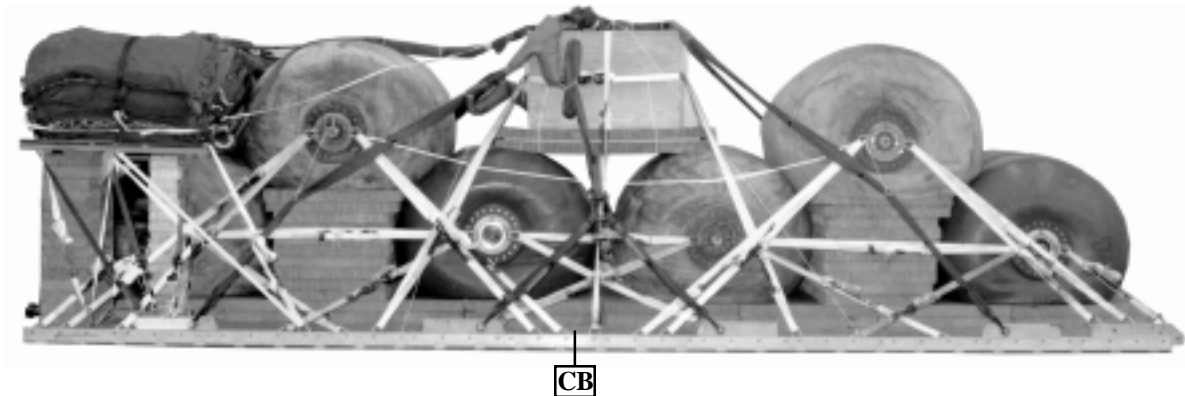
**Rigged Load Data**

Weight: Estimated, with gasoline	22,548 pounds
Maximum (as shown)	28,420 pounds
Height	92 inches
Width	108 inches
Length	288 inches
Overhang Front	5 inches
Rear	17 inches
CB (from front edge of platform)	150 inches
Extraction System (adds 18 inches to length of platform)	EFTC

Figure 4-69. Six drums with pumping assembly rigged on a 24-foot, type V airdrop platform for low-velocity airdrop

Table 4-7. Equipment required for rigging six drums with pumping assembly on a 24-foot, type V airdrop platform for low-velocity airdrop

National Stock Number	Item	Quantity
8040-00-273-8713	Adhesive, paste, 1-gal	As required
4030-00-678-8562	Clevis, suspension, 3/4-in (medium)	6
4030-00-090-5354	Clevis, suspension, 1-in (large)	14
4020-00-240-2146	Cord, nylon, type III, 550-lb	As required
1670-00-434-5782	Coupling, airdrop, extraction force transfer with cable, 24-ft	1
	Cover:	
1670-00-360-0328	Clevis, large	1
1670-00-360-0329	Link, type IV	7
8305-00-958-3685	Felt, 1/2-in thick	As required
1670-01-183-2678	Leaf, extraction line (line bag)	2
	Line, drogue (for C-17)	
1670-01-062-6316	60-ft (3-loop), type XXVI	1
	Line, extraction:	
1670-01-062-6316	60-ft (3-loop), type XXVI (for C-130)(Use w/ 140-ft for C-5)	1
1670-01-107-7651	140-ft (3-loop), type XXVI (for C-141B,C-5, or C-17)	1
	Link assembly:	
1670-01-307-0155	Three-point	2
1670-00-783-5988	Type IV	7
	Two-point:	
5306-00-435-8994	Bolt, 1-in diam, 4-in long	6
5310-00-232-5165	Nut, 1-in, hexagonal	6
1670-00-003-1954	Plate, side, 5 1/2-in	6
5365-00-007-3414	Spacer, large	6
	Lumber:	
5510-00-220-6146	2- by 4- by:	
	25 1/2	2
	41 1/2	2
5510-00-220-6148	2- by 6- by:	
	85-in	2
	48-in	2

Table 4-7. Equipment required for rigging six drums with pumping assembly on a 24-foot, type V airdrop platform for low-velocity airdrop (continued)

National Stock Number	Item	Quantity
5315-00-010-4659	Nail, steel wire, 8d	As required
1670-00-753-3928	Pad, energy-dissipating (honeycomb) 3- by 36- by 96-in	28 sheets
1670-01-016-7841	Parachute: Cargo: G-11C	6
1670-00-040-8135	Cargo extraction: 28-ft	1
1670-01-063-3715	Drogue (for C-17) 15-ft	1
1670-01-353-8425	Platform, airdrop, type V, 24-ft Bracket assembly, coupling	(1)
1670-01-162-2372	Clevis assembly, type V	(52)
1670-01-162-2376	Extraction bracket assembly	(1)
1670-01-162-2381	Tandem link assembly (Multipurpose link)	(2)
1670-01-247-2389	Suspension link	(8)
5530-00-128-4981	Plywood, 3/4 -by 48- by 96-in	2 sheets
1670-01-097-8817	Release, cargo parachute, M-2	1
1670-01-062-6306	Sling, cargo, airdrop For suspension: 3-ft (4-loop), type XXVI nylon webbing	8
1670-01-062-6305	9-ft (4-loop), type XXVI nylon webbing	2
1670-01-062-6308	16-ft (2-loop), type XXVI nylon webbing	4
1670-01-062-6304	For lifting: 9-ft (2-loop), type XXVI nylon webbing	2
1670-01-062-6304	For deployment: 9-ft (2-loop), type XXVI nylon webbing	1
1670-01-062-6311	For riser extension: 120-ft (2-loop), type XXVI nylon webbing	6

Table 4-7. Equipment required for rigging six drums with pumping assembly on a 24-foot, type V airdrop platform for low-velocity airdrop (continued)

National Stock Number	Item	Quantity
5340-00-040-8219	Strap, parachute release, multi-cut, comes w/ 3 knives	2
7510-00-266-5016	Tape, adhesive, 2-in	As required
1670-00-937-0271	Tie-down assembly, 15-foot	59
	Webbing:	
8305-00-268-2411	Cotton, 1/4-in, type I	As required
8305-00-082-5752	Nylon, tubular, 1/2-in	As required
8305-00-261-8584	Type X	As required

Section VIII**RIGGING SEVEN DRUMS WITHOUT PUMPING ASSEMBLY
ON A 28-FOOT PLATFORM****4-102. Description of Load**

Seven drums are rigged on a 28-foot, type V platform. Filled with 432 gallons of gasoline, each drum weighs 2,842 pounds and is 62 inches long and 53 inches in diameter. An empty drum weighs 250 pounds.

Note: Fill drums with no more than 432 gallons of fuel. If the drums are filled with a fuel other than gasoline, the drum weight must be computed.

4-103. Preparing Platform

Prepare a 28-foot, type V airdrop platform using two tandem links, eight suspension links and 50 clevises as shown in Figure 4-70.

Notes: 1. The nose bumper may or may not be installed.
2. Measurements given in this section are from the front edge of the platform, NOT from the front edge of the nose bumper.

WARNING

Do not add air to drums. Pressurization changes will cause leaking or bursting.

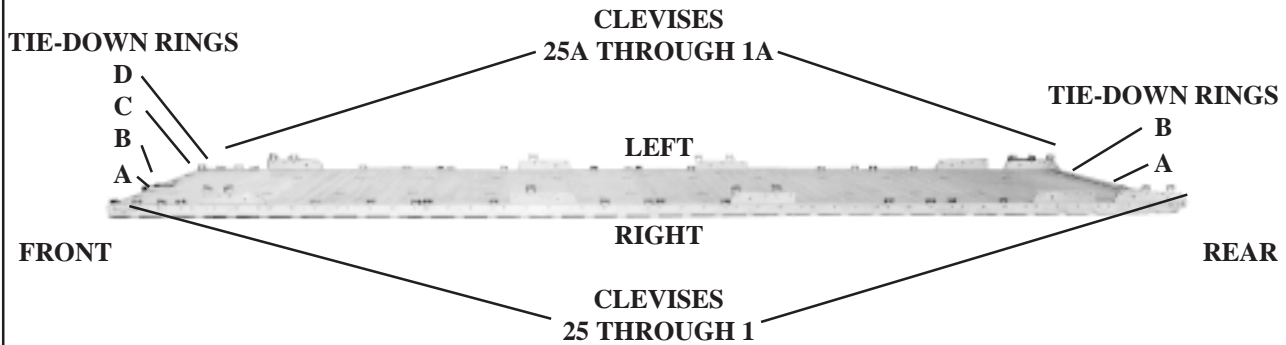

Step:

1. Inspect, or assemble and inspect, the platform as outlined in TM 10-1670-268-20&P/ TO 13C7-52-22.
2. Install suspension links on each platform side rail using holes 22, 23, and 24, and holes 6, 7, and 8.
3. Install a tandem link on the front of each platform side rail using holes 1, 2, and 3.
4. Install suspension links on each platform side rail using holes 33, 34, and 35, and holes 49, 50, and 51.
5. Bolt clevises on bushings 1, 3, and 4 of each front tandem link, on bushings 2 and 4 of each second suspension link, on bushing 3 of each third suspension link, and on bushings 2 and 4 of each rear suspension link.
6. Starting at the front of the platform, install clevises on each platform side rail using the bushings bolted on holes 10, 13, 14, 16, 25, 28, 29, 31, 37, 40, 41, 43, 46, 53, 54, 55 and 56.
7. Starting at the front of the platform, number the clevises bolted to the right side 1 through 25, and those bolted to the left side 1A through 25A.
8. Label the tiedown rings according to FM 10-500-2/TO 13C7-1-5.

Figure 4-70. Platform prepared

4-104. Preparing and Positioning Honeycomb Stacks

Prepare and position the honeycomb stack as shown in Figure 4-71.

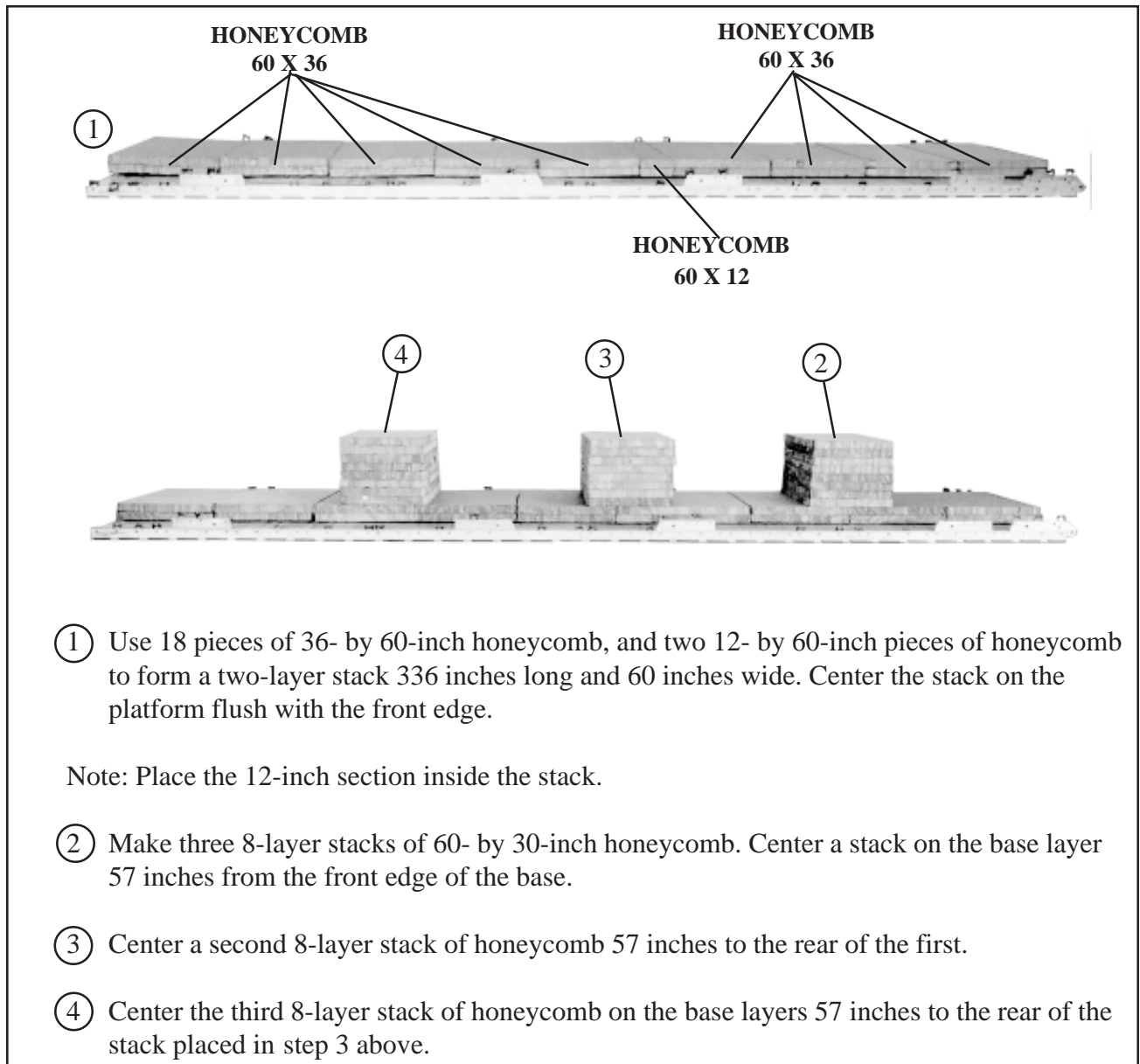

- ① Use 18 pieces of 36- by 60-inch honeycomb, and two 12- by 60-inch pieces of honeycomb to form a two-layer stack 336 inches long and 60 inches wide. Center the stack on the platform flush with the front edge.

Note: Place the 12-inch section inside the stack.

- ② Make three 8-layer stacks of 60- by 30-inch honeycomb. Center a stack on the base layer 57 inches from the front edge of the base.
- ③ Center a second 8-layer stack of honeycomb 57 inches to the rear of the first.
- ④ Center the third 8-layer stack of honeycomb on the base layers 57 inches to the rear of the stack placed in step 3 above.

Figure 4-71. Honeycomb stack positioned

4-105. Installing Lifting Slings and Positioning Drums

Lift the drums and position them on the honeycomb as shown in Figure 4-72.

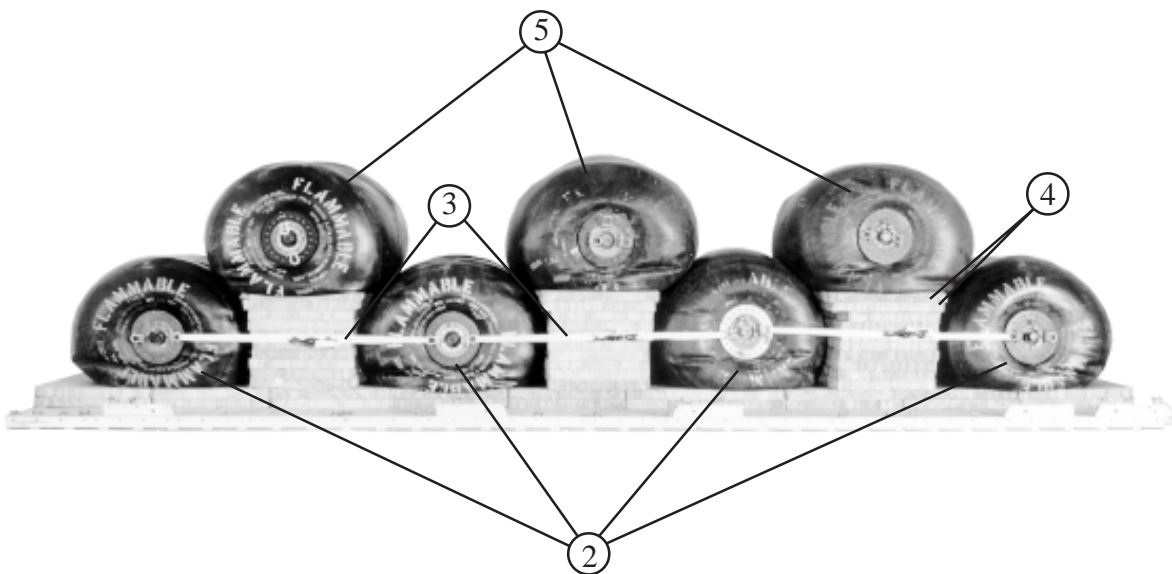

- ① Attach a 9-foot (2-loop), type XXVI nylon webbing sling to the upper shackle on each side of the drum with a platform clevis as shown in Figure 4-13.
- ② Lift four drums onto the honeycomb base as shown.
- ③ Lash the shackles of the drums together on each side with 15-foot tiedown assemblies.
- ④ Glue a 60- by 34-inch piece of honeycomb centered on each stack. Glue a 60- by 36-inch piece of honeycomb centered over the pieces placed previously.
- ⑤ Lift and position a drum onto each stack.

Figure 4-72. Fuel drums positioned

4-106. Lashing Drums

Use fifty 15-foot tie-down assemblies to lash the fuel drums as shown in Figure 4-73, and according to FM 10-500-2/TO 13C7-1-5.

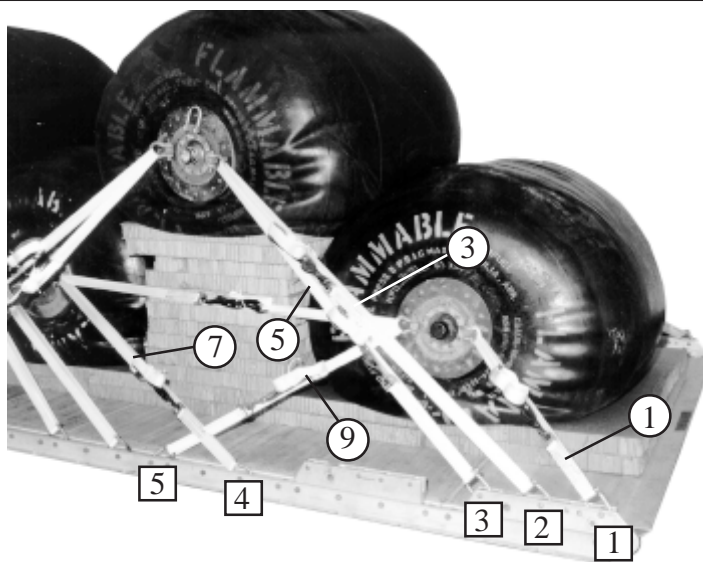

Lashing Number	Tie-down Clevis Number	Instructions
1	1	Pass lashing: Through right front shackle of first drum.
2	1A	Through left front shackle of first drum.
3	2	Through right front shackle of second drum.
4	2A	Through left front shackle of second drum.
5	3	Through right front shackle of second drum.
6	3A	Through left front shackle of second drum.
7	4	Through right front shackle of third drum.
8	4A	Through left front shackle of third drum.
9	5	Through right rear shackle of first drum.
10	5A	Through left rear shackle of first drum.

Figure 4-73. Fuel drums lashed to platform

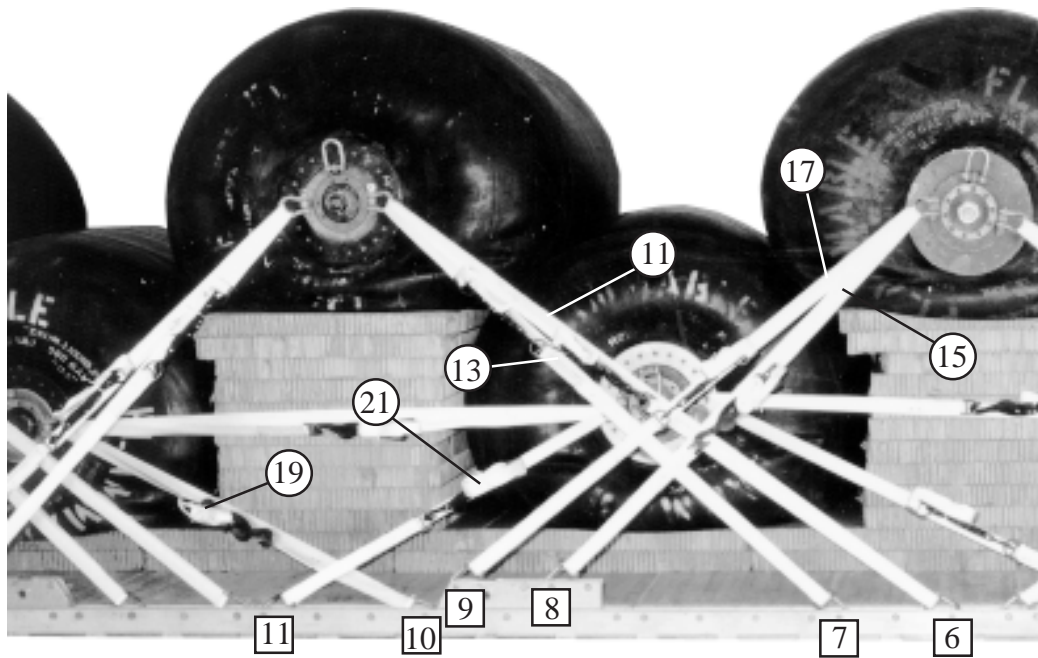

Lashing Number	Tie-down Clevis Number	Instructions
11	6	Pass lashing: Through right front shackle of fourth drum.
12	6A	Through left front shackle of fourth drum.
13	7	Through right front shackle of fourth drum.
14	7A	Through left front shackle of fourth drum.
15	8	Through right rear shackle of second drum.
16	8A	Through left rear shackle of second drum.
17	9	Through right rear shackle of second drum.
18	9A	Through left rear shackle of second drum.
19	10	Through right front shackle of fifth drum.
20	10A	Through left front shackle of fifth drum.
21	11	Through right rear shackle of third drum.
22	11A	Through left rear shackle of third drum.

Figure 4-73. Fuel drums lashed to platform (continued)

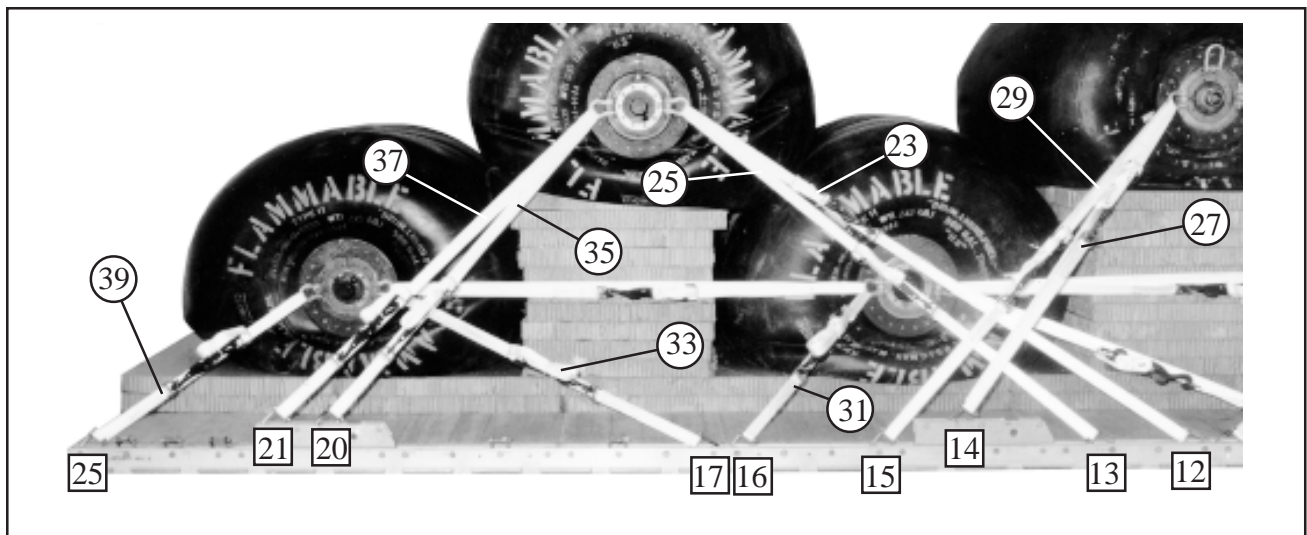

Lashing Number	Tie-down Clevis Number	Instructions
23	12	Pass lashing:
24	12A	Through right front shackle of sixth drum.
25	13	Through left front shackle of sixth drum.
26	13	Through right front shackle of sixth drum.
27	13A	Through left front shackle of sixth drum.
28	14	Through right rear shackle of fourth drum.
29	14A	Through left rear shackle of fourth drum.
30	15	Through right rear shackle of fourth drum.
31	15A	Through left rear shackle of fourth drum.
32	16	Through right rear shackle of fifth drum.
33	16A	Through left rear shackle of fifth drum.
34	17	Through right front shackle of seventh drum.
35	17A	Through left front shackle of seventh drum.
36	20	Through right rear shackle of sixth drum.
37	20A	Through left rear shackle of sixth drum.
38	21	Through right rear shackle of sixth drum.
39	21A	Through left rear shackle of sixth drum.
40	25	Through right rear shackle of seventh drum.
	25A	Through left rear shackle of seventh drum.

Figure 4-73. Fuel drums lashed to platform (continued)

4-107. Installing and Safeying Suspension Slings

Install the components of the centerline suspension system according to FM 10-500-2/TO 13C7-1-5, and as shown in Figure 4-74. Safety the suspension slings as shown in Figure 4-75.

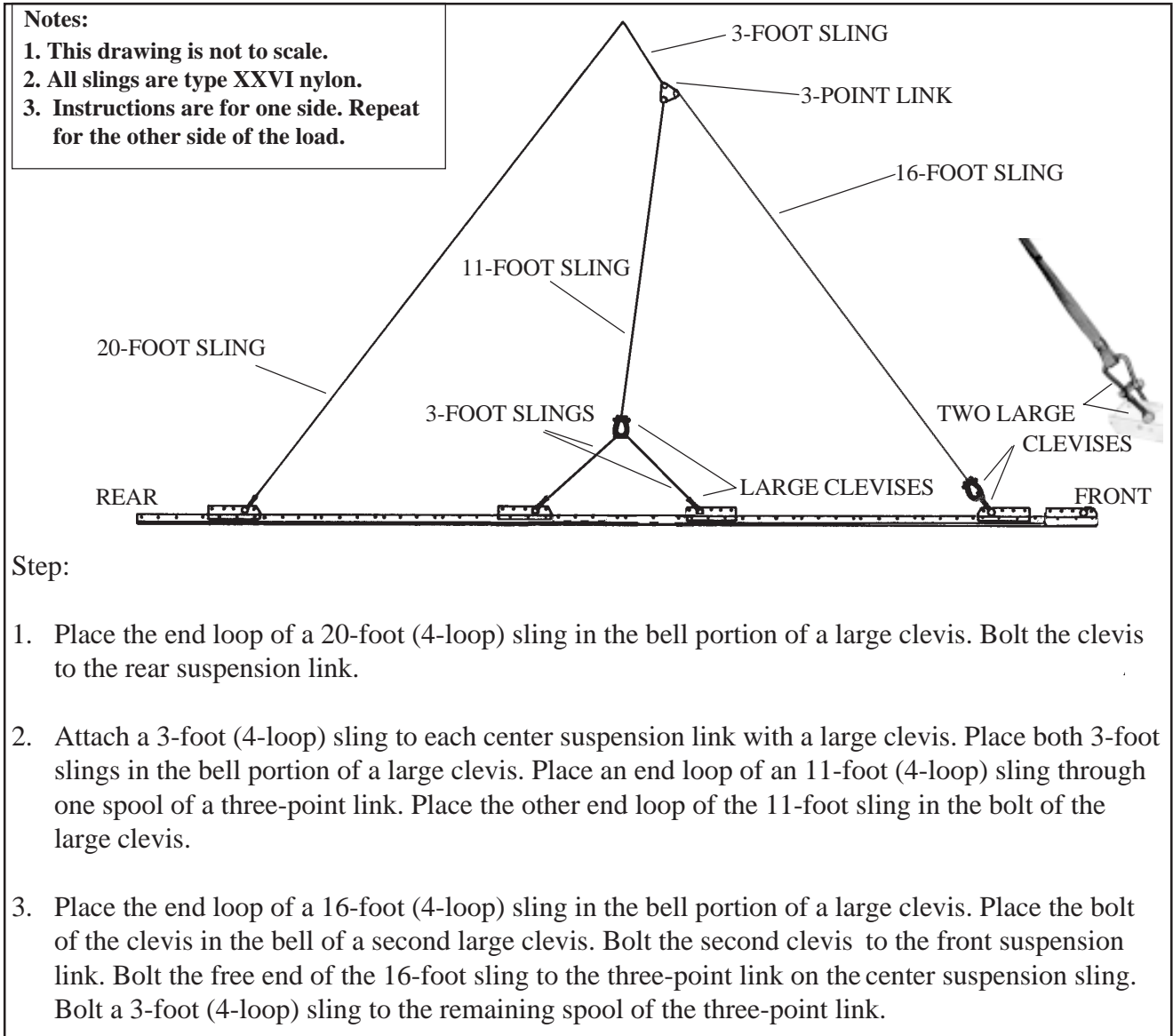
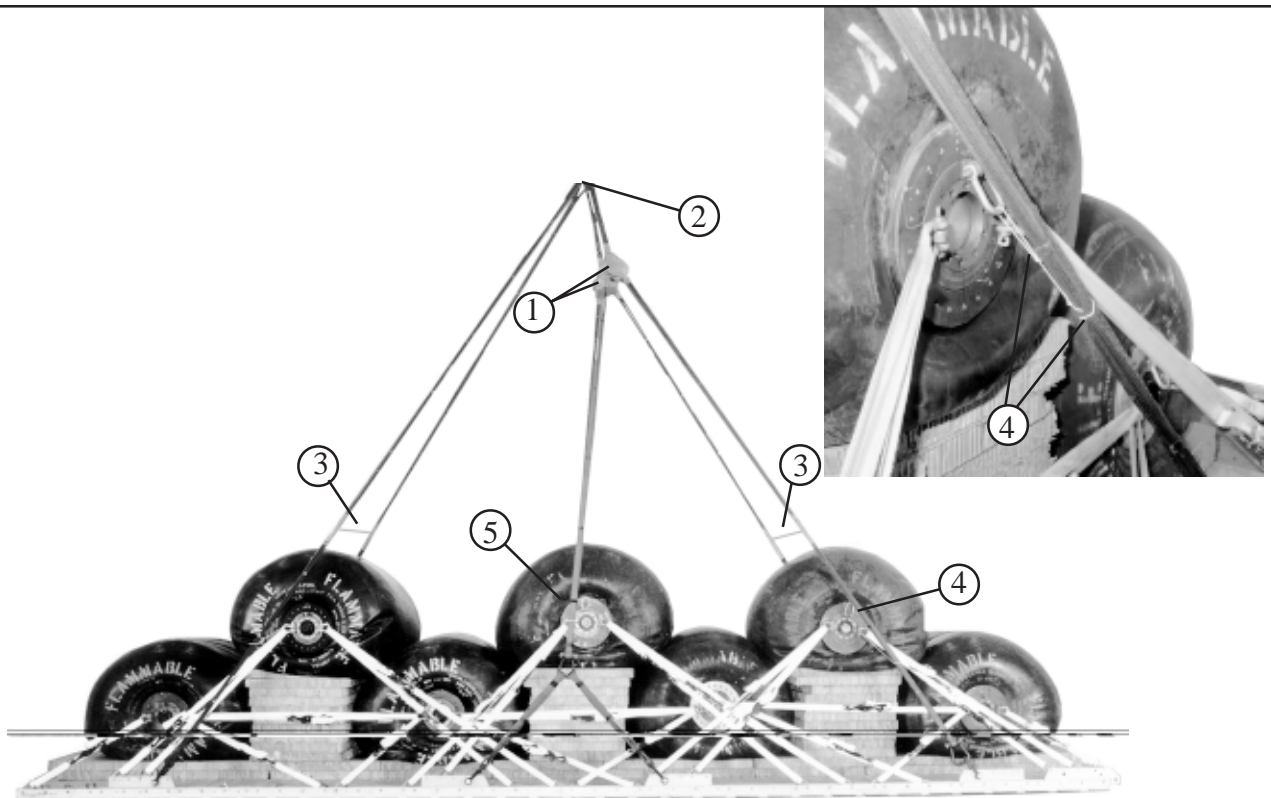

Figure 4-74. Suspension slings installed



- ① Pad the three-point links with felt taped in place.
- ② Attach the rear suspension slings and the 3-foot slings from the three-point links to the crane hook. Raise the suspension slings.
- ③ Tie the rear suspension slings to each other 12 inches above the load with a double length of 1/2-inch tubular nylon webbing. Tie the front suspension slings to each other in the same way.
- ④ Tie the front suspension slings to the upper shackle on the second drum with a length of type III nylon cord. Tie the rear suspension slings to the sixth drum in the same way.
- ⑤ Tie the upper clevises on the center suspension slings to the nearest shackle on the fourth drum with type III nylon cord.

Figure 4-75. Suspension slings safetied

4-108. Building and Lashing Parachute Stowage Platform

Build the parachute stowage platform and its supports as shown in Figure 4-76. Lash the parachute stowage platform to the load as shown in Figure 4-77.

Notes: 1. This drawing is not to scale.
 2. All dimensions are given in inches.
 3. Use eightpenny nails.

LUMBER
 2 X 6 X 85 2 IN DIAM HOLES

2 3/4

2 3/4

PLYWOOD
 3/4 X 48 X 96

LUMBER
 2 X 6 X 48

① Make two 17-layer stacks of 8- by 8-inch honeycomb. Place one stack on each side flush with the edge of the honeycomb supporting the rear drum and 29 inches from the rear edge of the platform.

② Make two 15-layer stacks of 12- by 12-inch honeycomb. Glue two 8- by 8-inch pieces of honeycomb on top of each stack flush with the inside front corners. Place the stacks on each side of the rear drum flush with the rear edge of the honeycomb base layer.

③ Center one or two 48- by 26-inch pieces of honeycomb over the rear drum.

④ Build the parachute stowage platform as shown. Nail the 2- by 6-inch pieces of lumber to the edges of the plywood, and drill 2-inch holes for the lashings.

Figure 4-76. Supports placed and parachute stowage platform constructed

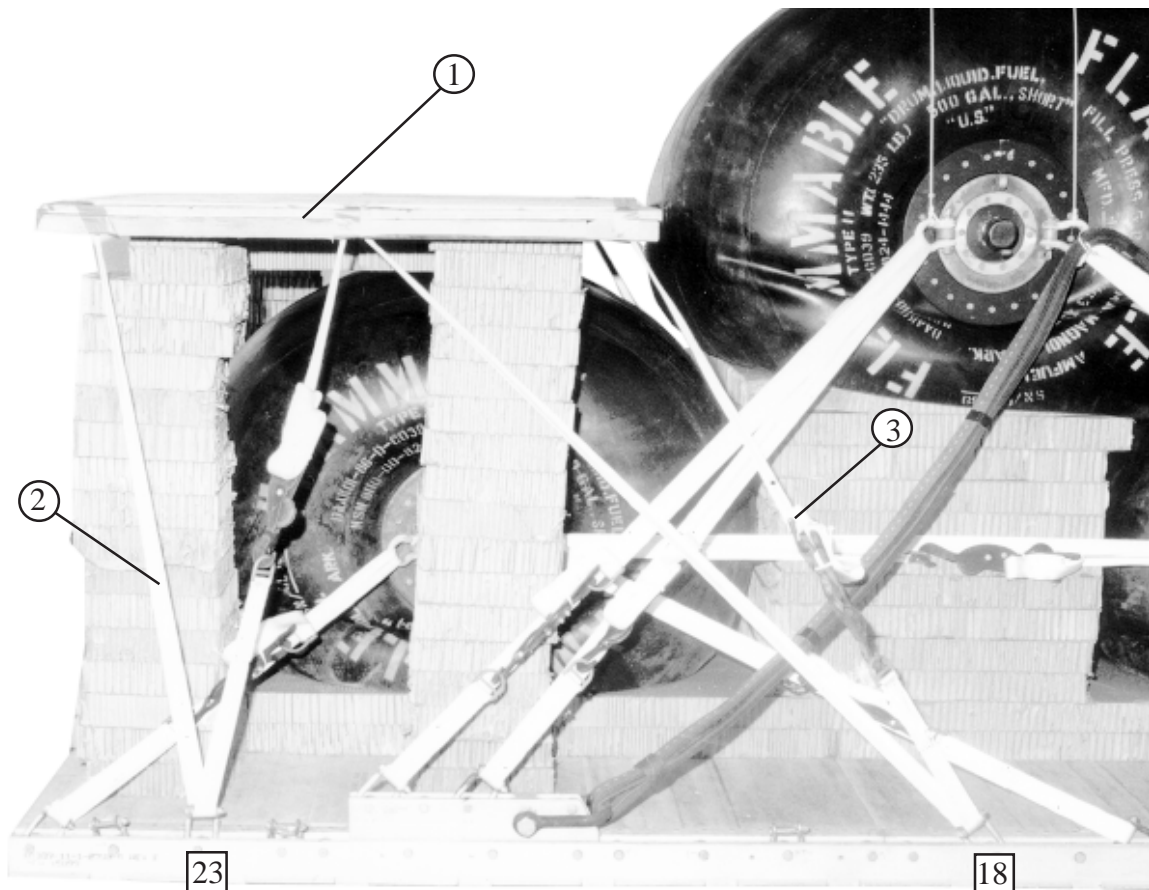

- ① Center the parachute stowage platform on the honeycomb placed in Figure 4-76. Remove or add honeycomb if necessary for a snug fit.
- ② Lash the two rear holes in the parachute stowage platform to clevises 23 and 23A.
- ③ Lash the two front holes in the parachute stowage platform to clevises 18 and 18A.

Figure 4-77. Parachute stowage platform lashed to platform rails

4-109. Installing Cargo Parachutes

Install seven G-11 cargo parachutes as shown in Figure 4-78, and according to FM 10-500-2/TO 13C7-1-5.

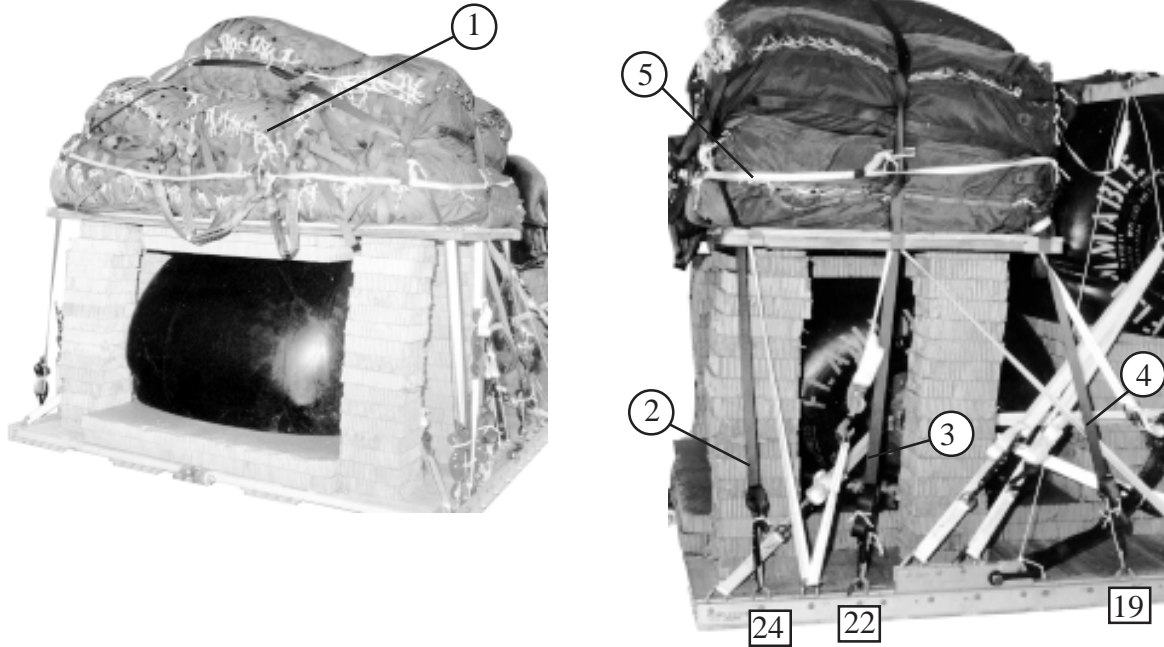

- ① Cluster seven G-11 cargo parachutes on the parachute stowage platform.
- ② Pass the rear restraint strap through the rear holes in the parachute stowage platform, and attach the ends to inverted clevises 24 and 24A with D-rings and load binders.
- ③ Pass the center restraint strap through the center holes in the parachute stowage platform, and attach the ends to inverted clevises 22 and 22A with D-rings and load binders.
- ④ Pass the front restraint strap through the front holes in the parachute stowage platform, and attach the ends to inverted clevises 19 and 19A with D-rings and load binders.
- ⑤ Install the parachute release knives according to FM 10-500-2/TO 13C7-1-5.

Figure 4-78. G-11 cargo parachutes installed

4-110. Installing Parachute Release

Prepare and install an M-2 cargo parachute release as shown in Figure 4-79, and according to FM 10-500-2/TO 13C7-1-5.

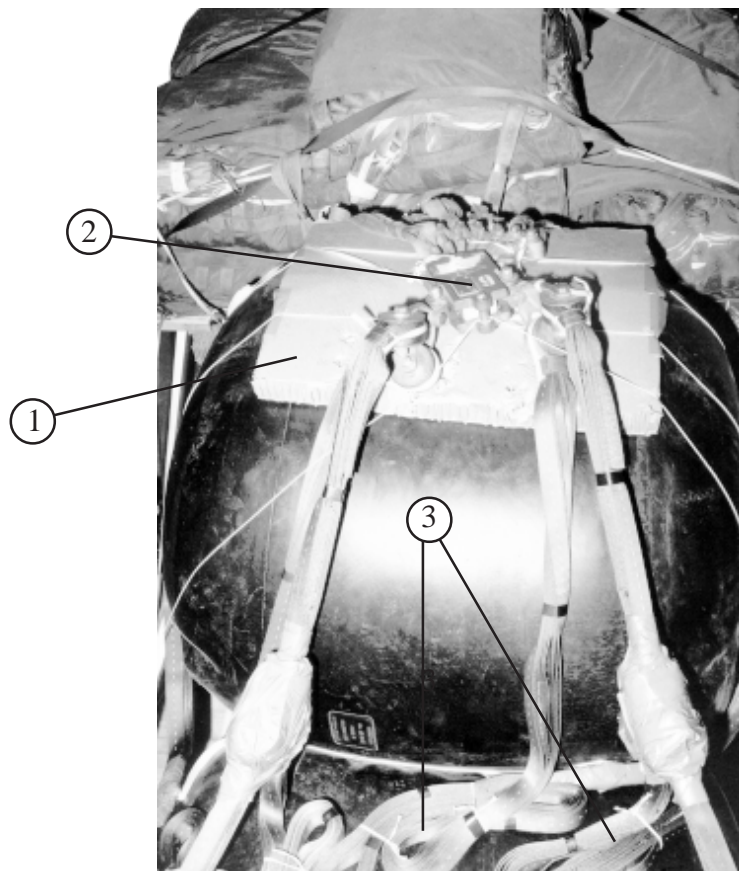

- ① Center a 36 -by 36-inch piece of honeycomb over the sixth drum. Secure the honeycomb to the drum shackles with type III nylon cord.
- ② Attach the suspension slings and the riser extensions to the M-2 release according to FM 10-500-2/TO 13C7-1-5. Secure the release to the platform with type III nylon cord.
- ③ S-fold the suspension slings and tie the folds with type I, 1/4-inch cotton webbing.

Figure 4-79. M-2 release installed

4-111. Installing Extraction System

Prepare and install the EFTC extraction system as shown in Figure 4-80, and according to FM 10-500-2/TO 13C7-1-5.

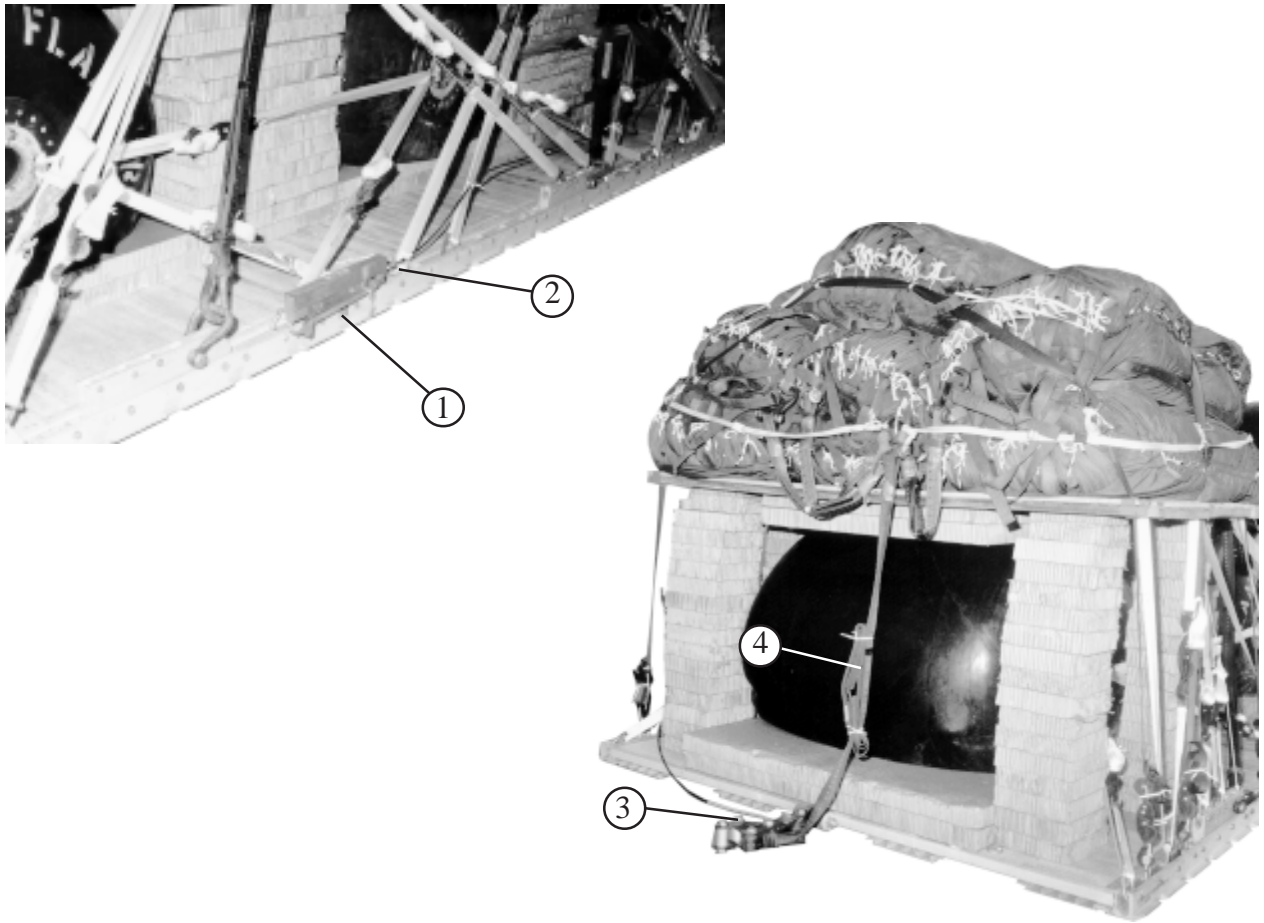

- ① Install the actuator mounting brackets to the rear holes on the left platform rail.
- ② Install a 28-foot cable to the actuator. Install the actuator to the brackets.
- ③ Attach the latch assembly to the extraction bracket. Attach the cable to the latch assembly.
- ④ Install a 9-foot (2-loop), type XXVI nylon webbing sling as the deployment line. S-fold and tie the excess in two places with type I, 1/4-inch cotton webbing.

Figure 4-80. EFTC installed

4-112. Installing Provisions for Emergency Restraints

Select and install provisions for emergency restraints according to the emergency aft restraint requirements table in FM 10-500-2/TO 13C7-1-5.

4-113. Placing Extraction Parachute

Select the extraction parachute and extraction line needed using the extraction line requirements table in FM 10-500-2/TO 13C7-1-5. Place the extraction parachute and extraction line on the load for installation in the aircraft.

4-114. Marking Rigged Load

Mark the rigged load according to FM 10-500-2/TO 13C7-1-5 and as shown in Figure 4-81.

CAUTION

The load weight may vary from the one shown, depending upon the fuel rigged. Be sure that the load is weighed, and the parachute requirements, CB, and tip-off curve recomputed.

4-115. Equipment Required

Use the equipment listed in Table 4-8 to rig this load.

CAUTION
Make the final rigger inspection required by FM 10-500-2/TO 13C7-1-5
before the load leaves the rigging site.

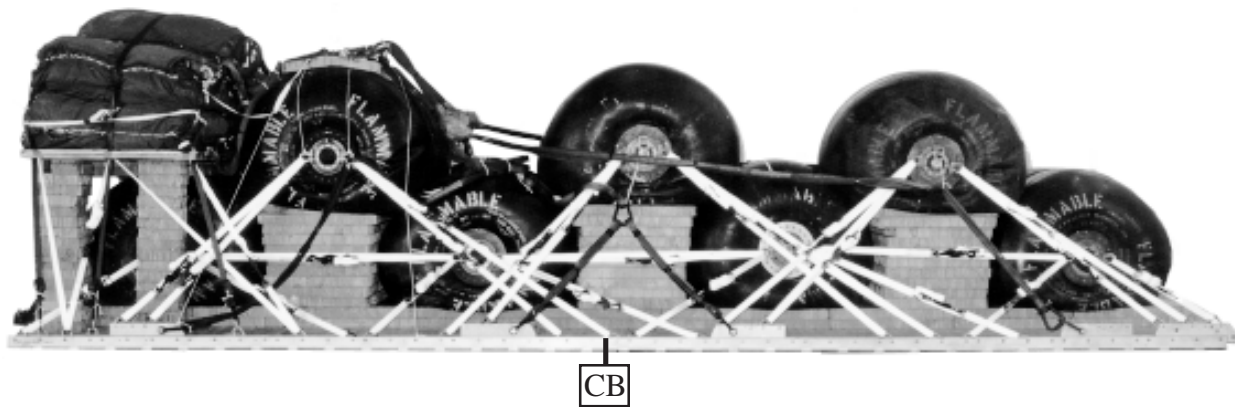

Rigged Load Data

Weight:	Estimated, with gasoline	24,781 pounds
	Maximum (as shown)	31,735 pounds
Height		90 inches
Width		108 inches
Length		336 inches
Overhang Front		5 inches
	Rear	17 inches
CB (from front edge of platform)		176 inches
Extraction System (adds 18 inches to length of platform)		EFTC

Figure 4-81. Seven drums rigged on a 28-foot, type V airdrop platform for low-velocity airdrop

Table 4-8. Equipment required for rigging seven drums without pumping assembly on a 28-foot, type V airdrop platform for low-velocity airdrop

National Stock Number	Item	Quantity
8040-00-273-8713	Adhesive, paste, 1-gal	As required
4030-00-678-8562	Clevis, suspension, 3/4-in (medium)	6
4030-00-090-5354	Clevis, suspension, 1-in (large)	16
4020-00-240-2146	Cord, nylon, type III, 550-lb	As required
1670-01-326-7309	Coupling, airdrop, extraction force transfer with cable, 28-ft	1
	Cover:	
1670-00-360-0328	Clevis, large	1
1670-00-360-0329	Link, type IV	8
8305-00-958-3685	Felt, 1/2-in thick	As required
1670-01-183-2678	Leaf, extraction line (line bag)	2
	Line, drogue (for C-17)	
1670-01-062-6313	60-ft (3-loop), type XXVI	1
	Line, extraction:	
1670-01-064-4454	60-ft (6-loop), type XXVI (for C-130)	1
1670-01-062-6312	120-ft (6-loop), type XXVI (for C-141B or C-5)	1
NO NSN	140-ft (6-loop), type XXVI (for C-17)	1
	Link assembly:	
1670-01-307-0155	Three-point	2
1670-00-783-5988	Type IV	8
1670-00-006-2752	Four-point	1
5510-00-220-6148	Lumber: 2- by 6- by:	
	85-in	2
	48-in	2

Table 4-8. Equipment required for rigging seven drums without pumping assembly on a 28-foot, type V airdrop platform for low-velocity airdrop (continued)

National Stock Number	Item	Quantity
5315-00-010-4659	Nail, steel wire, 8d	As required
1670-00-753-3928	Pad, energy-dissipating (honeycomb) 3- by 36- by 96-in	32 sheets
	Parachute:	
	Cargo:	
1670-01-016-7841	G-11C	7
	Cargo extraction:	
1670-00-040-8135	28-ft	2
	Drogue (for C-17)	
1670-01-063-3715	15-ft	1
	Platform, airdrop, type V, 28-ft	
1670-01-353-8425	Bracket assembly, coupling	(1)
1670-01-162-2372	Clevis assembly, type V	(50)
1670-01-162-2376	Extraction bracket assembly	(1)
1670-01-162-2381	Tandem link assembly (Multipurpose link)	(2)
1670-01-247-2389	Suspension link	(8)
5530-00-128-4981	Plywood, 3/4 -by 48- by 96-in	1 sheet
1670-01-097-8817	Release, cargo parachute, M-2	1
	Sling, cargo, airdrop	
	For suspension:	
1670-01-062-6306	3-ft (4-loop), type XXVI nylon webbing	6
1670-01-062-6310	11-ft (4-loop), type XXVI nylon webbing	2
1670-01-062-6308	16-ft (4-loop), type XXVI nylon webbing	2
1670-01-064-4453	20-ft (4-loop), type XXVI nylon webbing	2
	For lifting:	
1670-01-062-6304	9-ft (2-loop), type XXVI nylon webbing	2
	For deployment:	
1670-01-062-6304	9-ft (2-loop), type XXVI nylon webbing	1
	For riser extension:	
1670-01-062-6311	120-ft (2-loop), type XXVI nylon webbing	7

Table 4-8. Equipment required for rigging seven drums without pumping assembly on a 28-foot, type V airdrop platform for low-velocity airdrop (continued)

National Stock Number	Item	Quantity
5340-00-040-8219	Strap, parachute release, multi-cut, comes w/ 3 knives	2
7510-00-266-5016	Tape, adhesive, 2-in	As required
1670-00-937-0271	Tie-down assembly, 15-foot	46
	Webbing:	
8305-00-268-2411	Cotton, 1/4-in, type I	As required
8305-00-082-5752	Nylon, tubular, 1/2-in	As required
8305-00-261-8584	Type X	As required

Section IX

**RIGGING SEVEN DRUMS WITH PUMPING ASSEMBLY
ON A 28-FOOT PLATFORM**

4-116. Description of Load

Seven drums are rigged with the pumping assembly on a 28-foot, type V platform. Filled with 432 gallons of gasoline, each drum weighs 2,842 pounds and is 62 inches long and 53 inches in diameter. An empty drum weighs 250 pounds.

Note: Fill drums with no more than 432 gallons of fuel. If the drums are filled with a fuel other than gasoline, the drum weight must be computed.

4-117. Preparing Platform

Prepare a 28-foot, type V airdrop platform using two tandem links, eight suspension links and 54 clevises as shown in Figure 4-82.

Notes: 1. The nose bumper may or may not be installed.
2. Measurements given in this section are from the front edge of the platform, NOT from the front edge of the nose bumper.

WARNING

Do not add air to drums. Pressurization changes will cause leaking or bursting.

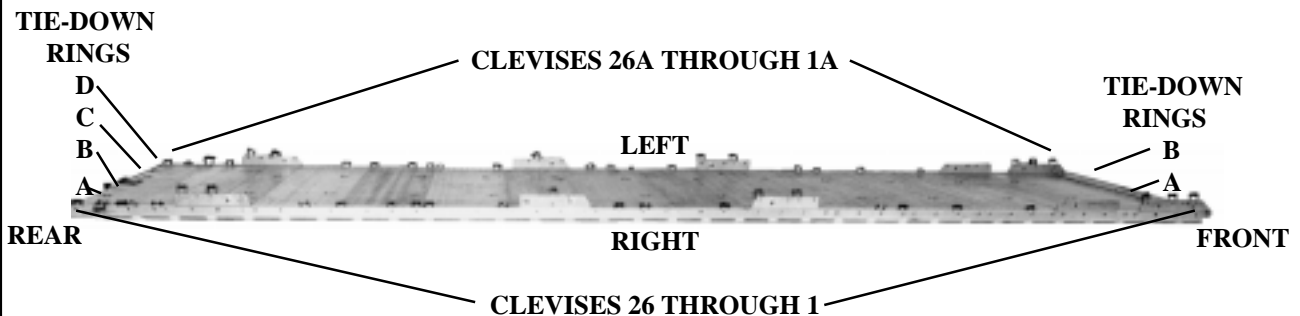

Step:

1. Inspect, or assemble and inspect, the platform as outlined in TM 10-1670-268-20&P/TO 13C7-52-22.
2. Install suspension links on each platform side rail using holes 22, 23, and 24, and holes 6, 7, and 8.
3. Install a tandem link on the front of each platform side rail using holes 1, 2, and 3.
4. Install suspension links on each platform side rail using holes 33, 34, and 35, and holes 49, 50, and 51.
5. Bolt clevises on bushings 1, 3, and 4 of each front tandem link, on bushings 2 and 4 of each second suspension link, on bushing 2 of each third suspension link, and on bushings 2 and 4 of each rear suspension link.
6. Install a clevis on bushings 54 and 55 in an inverted position on each platform side rail. Bolt one additional clevis to each inverted clevis.
7. Starting at the front of the platform, install clevises on each platform side rail using the bushings bolted on holes 10, 14, 17, 18, 26, 30, 31, 37, 40, 41, 42, 44, 46, 53, and 56.
8. Starting at the front of the platform, number the clevises bolted to the right side 1 through 26, and those bolted to the left side 1A through 26A.
9. Label the tie-down rings according to FM 10-500-2/TO 13C7-1-5.

Figure 4-82. Platform prepared

4-118. Preparing and Positioning Honeycomb Stack

Prepare and position the honeycomb stack as shown in Figure 4-83.

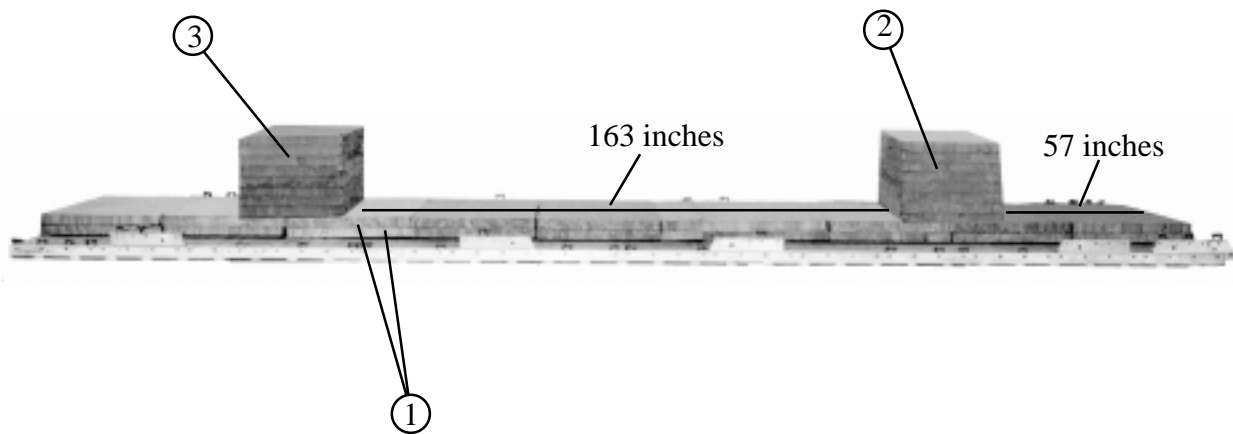

- ① Use 18 pieces of 36- by 60-inch honeycomb, and two pieces 12- by 60 inches to form a two-layer stack 336 inches long and 60 inches wide. Center the stack on the platform flush with the front edge.

Note: Place the 12-inch section inside the stack.

- ② Make two 8-layer stacks of 60- by 30-inch honeycomb. Center a stack on the base layer 57 inches from the front edge of the base.
- ③ Center the other stack on the base layers 163 inches to the rear of the stack placed in step 2.

Figure 4-83. Honeycomb stack positioned

4-119. Installing Lifting Slings and Positioning Drums

Lift the drums and position them on the honeycomb as shown in Figure 4-84.

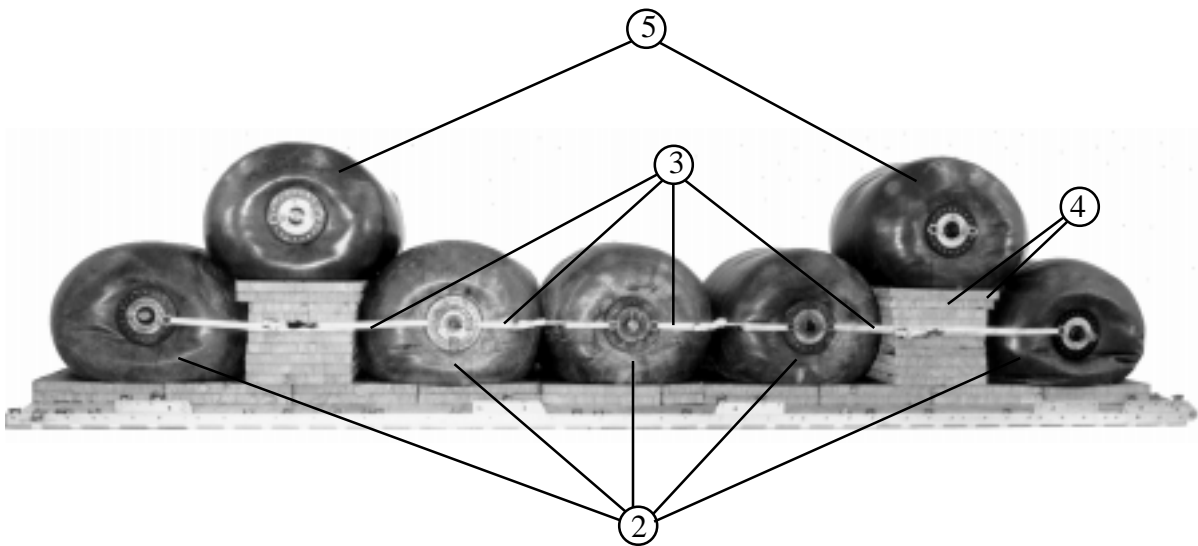

- ① Attach a 9-foot (2-loop), type XXVI nylon webbing sling to the upper shackle on each side of the drum with a platform clevis as shown in Figure 4-13.
- ② Lift five drums onto the honeycomb base as shown.
- ③ Lash the shackles of the drums together on each side with 15-foot tie-down assemblies.
- ④ Glue a 60- by 34-inch piece of honeycomb centered on each stack. Glue a 60- by 36-inch piece of honeycomb centered over the pieces placed previously.
- ⑤ Lift and position a drum onto each stack.

Figure 4-84. Fuel drums positioned

4-120. Lashing Drums

Use thirty-eight 15-foot tie-down assemblies to lash the fuel drums to the platform as shown in Figure 4-85, and according to FM 10-500-2/TO 13C7-1-5.

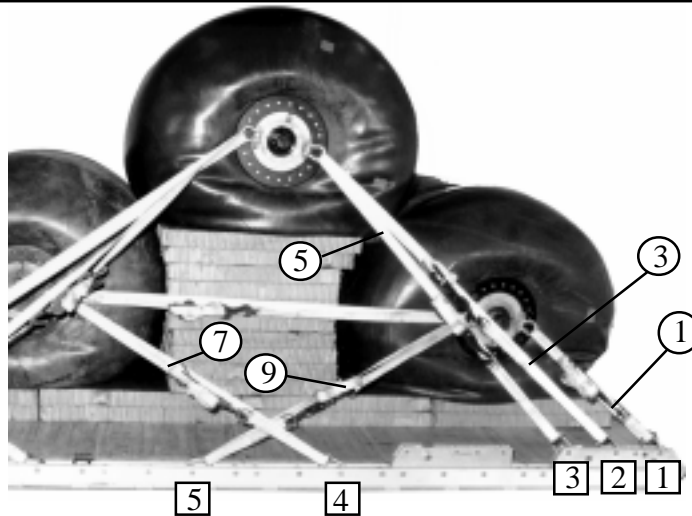

Lashing Number	Tie-down Clevis Number	Instructions
1	1	Pass lashing:
2	1A	Through right front shackle of first drum.
3	2	Through left front shackle of first drum.
4	2A	Through right front shackle of second drum.
5	3	Through left front shackle of second drum.
6	3A	Through right front shackle of second drum.
7	4	Through left front shackle of second drum.
8	4A	Through right front shackle of third drum.
9	5	Through left front shackle of third drum.
10	5A	Through right rear shackle of first drum.
		Through left rear shackle of first drum.

Figure 4-85. Fuel drums lashed to platform

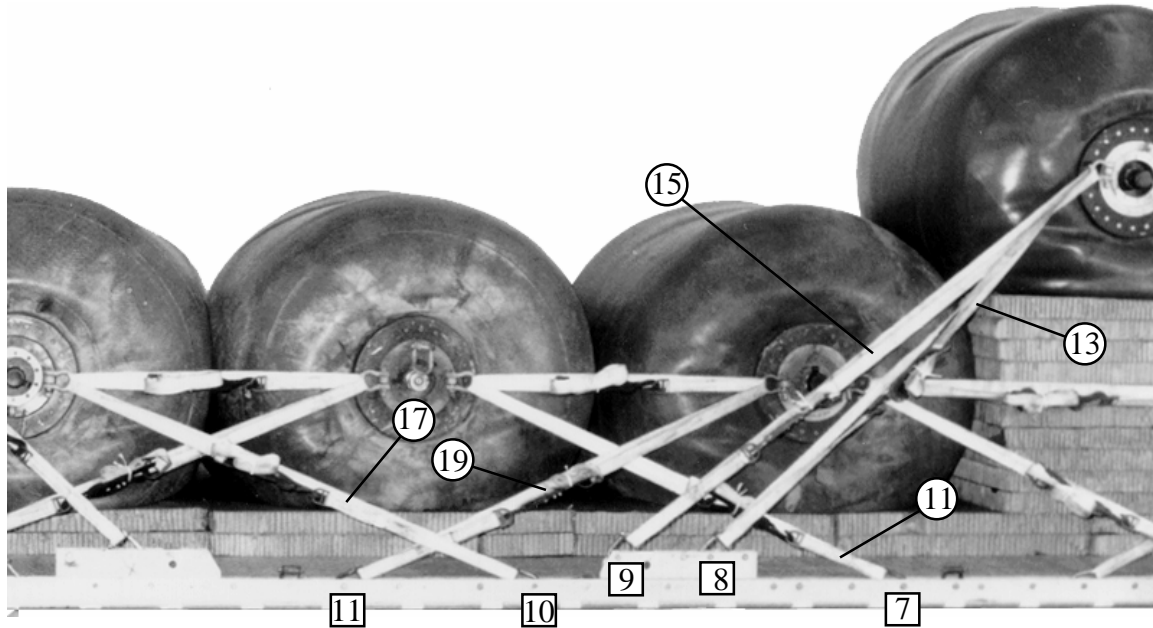

Lashing Number	Tie-down Clevis Number	Instructions
11	7	Pass lashing:
12	7A	Through right front shackle of fourth drum.
13	8	Through left front shackle of fourth drum.
14	8A	Through right rear shackle of second drum.
15	8A	Through left rear shackle of second drum.
16	9	Through right rear shackle of second drum.
17	9A	Through left rear shackle of second drum.
18	10	Through right front shackle of fifth drum.
19	10A	Through left front shackle of fifth drum.
20	11	Through right rear shackle of third drum.
	11A	Through left rear shackle of third drum.

Figure 4-85. Fuel drums lashed to platform (continued)

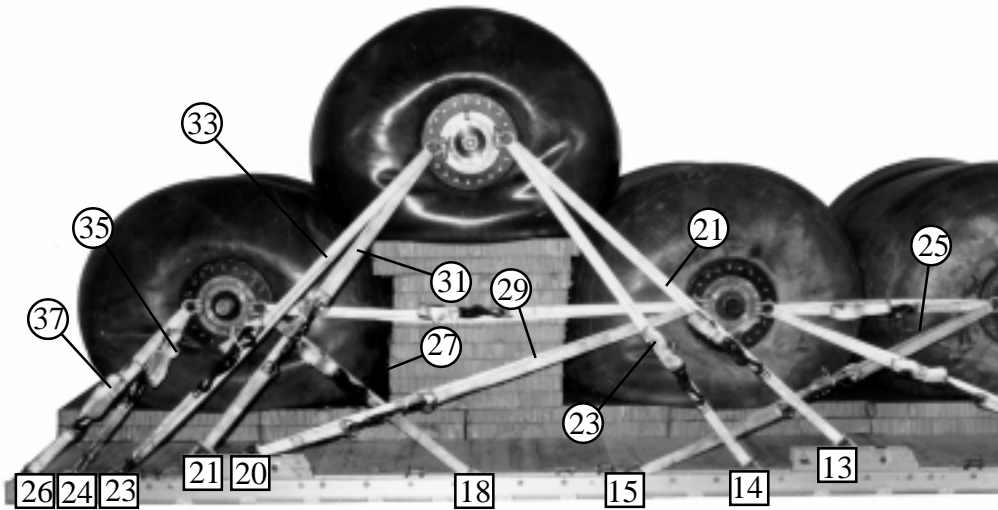

Lashing Number	Tie-down Clevis Number	Instructions
21	13	Pass lashing:
22	13A	Through right front shackle of sixth drum.
23	14	Through left front shackle of sixth drum.
24	14A	Through right front shackle of sixth drum.
25	15	Through left front shackle of sixth drum.
26	15A	Through right rear shackle of fourth drum.
27	18	Through left rear shackle of fourth drum.
28	18A	Through right front shackle of seventh drum.
29	20	Through left front shackle of seventh drum.
30	20A	Through right rear shackle of fifth drum.
31	21	Through left rear shackle of fifth drum.
32	21A	Through right rear shackle of sixth drum.
33	23	Through left rear shackle of sixth drum.
34	23A	Through right rear shackle of sixth drum.
35	24	Through left rear shackle of sixth drum.
36	24A	Through right rear shackle of seventh drum.
37	26	Through left rear shackle of seventh drum.
38	26A	Through right rear shackle of seventh drum.
		Through left rear shackle of seventh drum.

Figure 4-85. Fuel drums lashed to platform (continued)

4-121. Preparing Pump Assembly

Build the box for the pump assembly as shown in Figure 4-86. Pack the pump assembly and hoses in the box as shown in Figure 4-87.

Notes: 1. These drawings are not to scale.
2. Use 8d nails.
3. All dimensions are in inches.

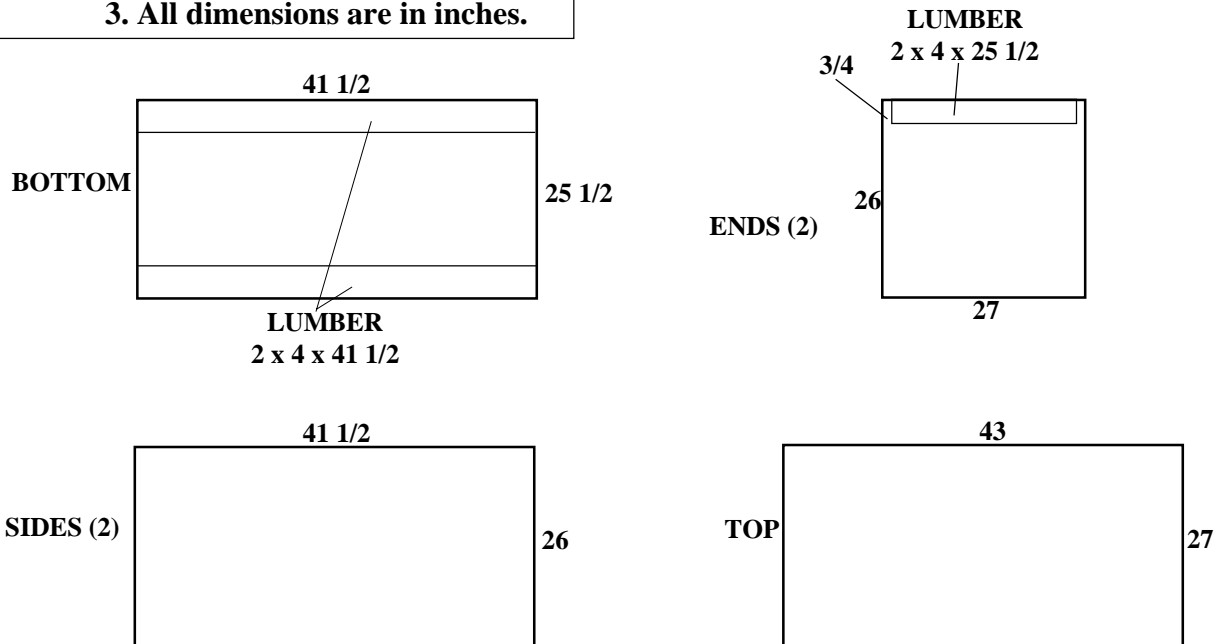
**Step:**

1. Cut the bottom of the box from 3/4-inch plywood 41 1/2 inches long and 25 1/2 inches wide. Nail a 41 1/2-inch length of 2- by 4-inch lumber flat side down and flush along each long edge of the bottom. The top of the box is 43- by 27 inches.
2. Cut the sides of the box from 3/4-inch plywood 41 1/2 inches long and 26 inches high. Place the sides flush with the bottom. Nail into the 2- by 4-inch pieces of lumber.
3. Cut the ends of the box from 3/4-inch plywood 27 inches wide and 26 inches high. Nail a 25 1/2-inch piece of 2- by 4-inch lumber flat side down, centered, and flush with the top edge of each end piece. Nail the ends flush to the bottom and sides. Nail the sides to the 2- by 4-inch pieces of lumber on the ends.

Figure 4-86. Pump assembly box built

4-122. Lashing Pump Assembly to Platform

Place the pump assembly box on the load and lash it to the platform as shown in Figure 4-88.

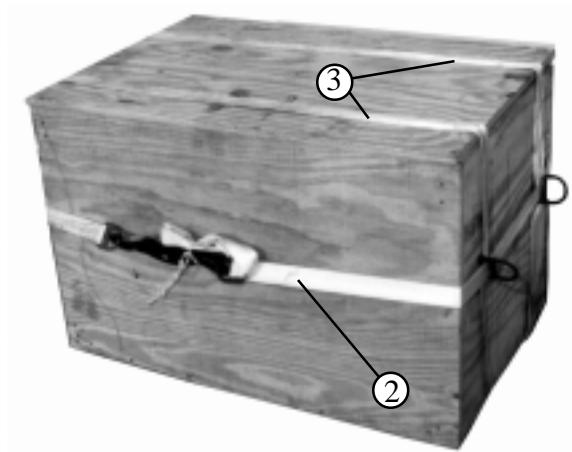
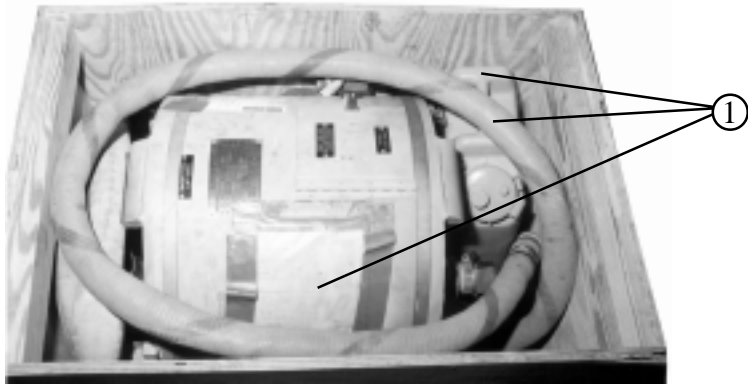

- ① Place the pump, its hoses, a 5-gallon can of fuel, and any other items needed by the unit in the box. Pad the items with cellulose wadding. Nail the top to the box.
- ② Place four D-rings onto a 15-foot lashing. Place the lashing around the box lengthwise, and position two D-rings on each end of the box, 6 inches from each side. Tighten the lashing.
- ③ Pass two 15-foot lashings around the box and through the D-rings as shown. Tighten the lashings.

Figure 4-87. Pump assembly box packed

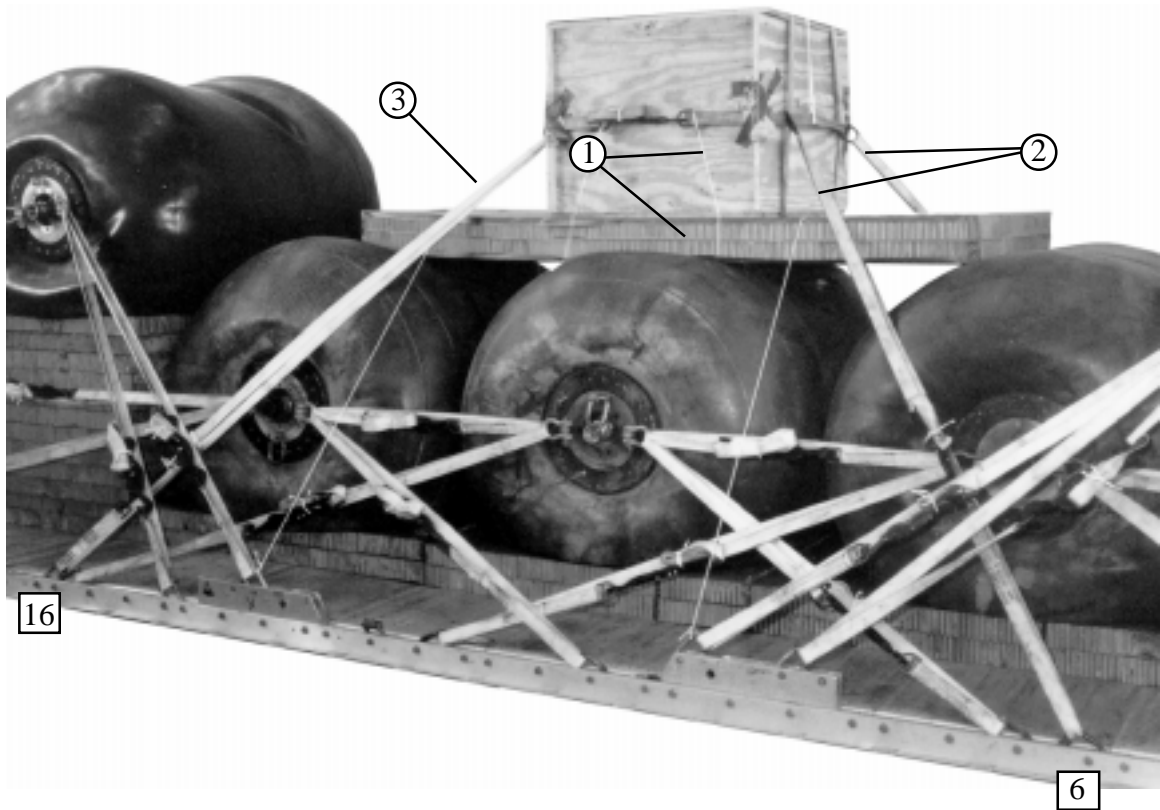

- ① Center two 96- by 36-inch pieces of honeycomb over the third, fourth, and fifth drums. Tape the edges of the honeycomb and secure the honeycomb to the load with type III nylon cord. Center the pump box on the honeycomb with the D-rings facing the front and rear.
- ② Lash the right front D-ring on the box to clevis 6. Lash the left front D-ring to clevis 6A.
- ③ Lash the right rear D-ring on the box to clevis 16. Lash the left rear D-ring to clevis 16A.

Figure 4-88. Pump assembly box lashed to platform

4-123. Installing and Safeying Suspension Slings

Install the components of the centerline suspension system according to FM 10-500-2/TO 13C7-1-5 and as shown in Figure 4-89. Safety the suspension slings as shown in Figure 4-90.

Notes
 1. This drawing is not to scale.
 2. All slings are type XXVI nylon.
 3. Instructions are for one side. Repeat for the other side of the load.

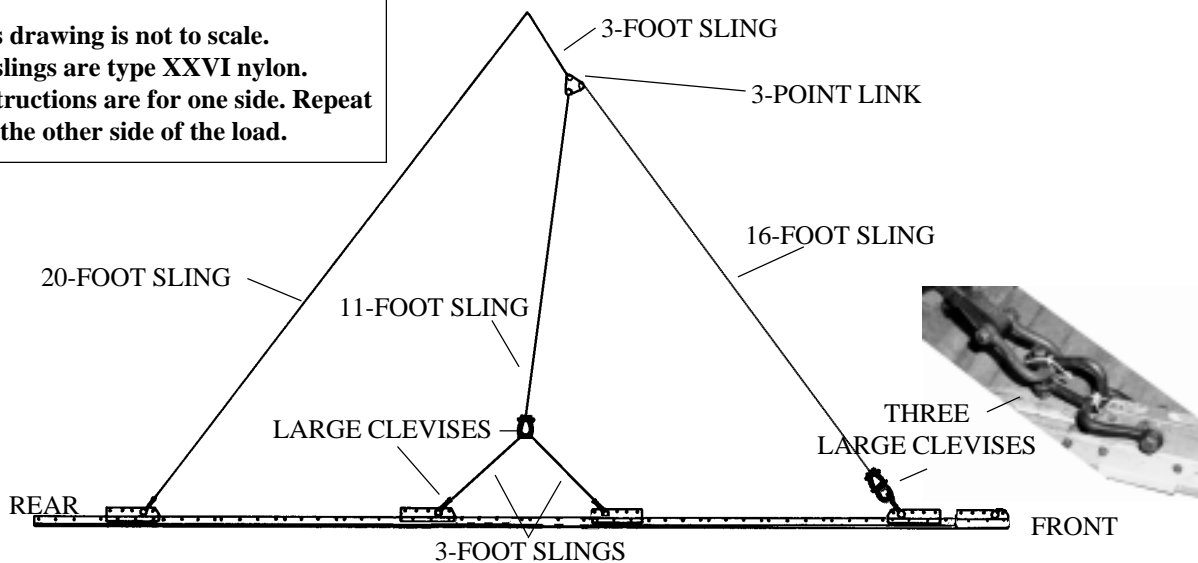

Step:

1. Place the end loop of a 20-foot (4-loop) sling in the bell portion of a large clevis. Bolt the clevis to the rear suspension link.
2. Attach a 3-foot (4-loop) sling to each center suspension link with a large clevis. Place both 3-foot slings in the bell portion of a large clevis. Place an end loop of an 11-foot (4-loop) sling through one spool of a three-point link. Place the other end loop of the 11-foot sling in the bolt of the large clevis.
3. Place the end loop of a 16-foot (4-loop) sling in the bell portion of a large clevis. Place the bolt of the clevis in the bell of a second large clevis. Attach the second clevis to the front suspension link with a third large clevis. Bolt the free end of the 16-foot sling to the three-point link on the center suspension sling. Bolt a 3-foot (4-loop) sling to the remaining spool of the three-point link.

Figure 4-89. Suspension slings installed

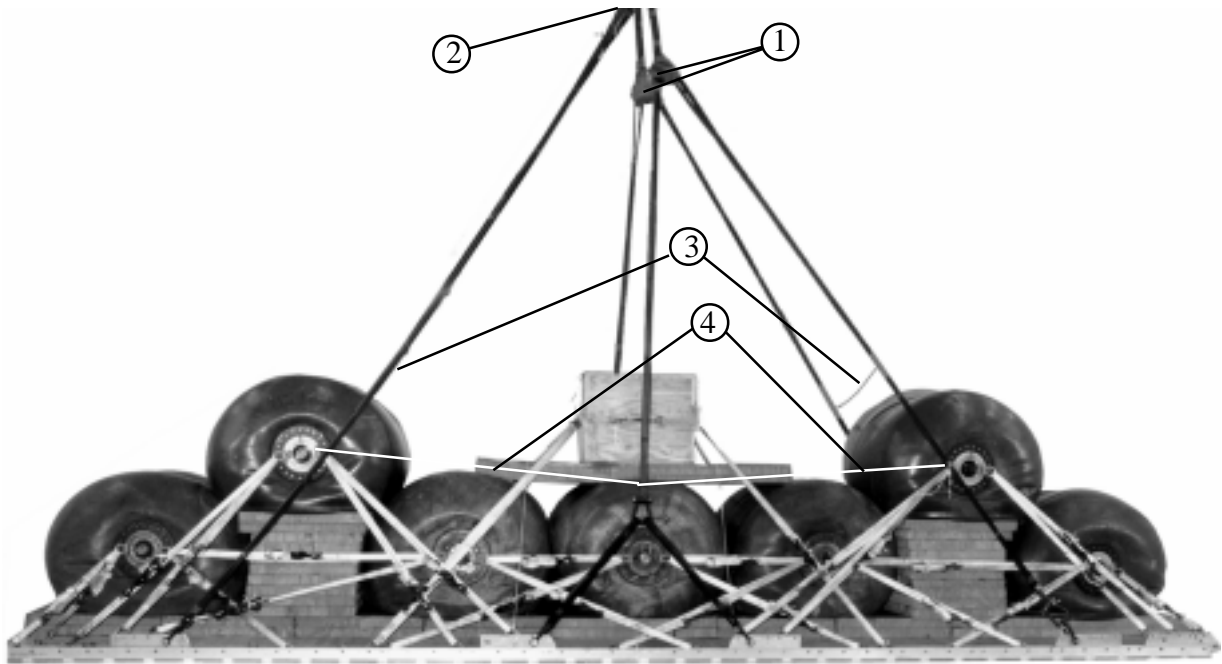

- ① Pad the three-point links with felt taped in place.
- ② Attach the rear suspension slings and the 3-foot slings from the three-point links to the crane hook. Raise the suspension slings.
- ③ Tie the rear suspension slings to each other 12 inches above the load with a double length of 1/2-inch tubular nylon webbing. Adapt the procedures in Figure 3-12, FM 10-500-2/TO 13C7-1-5 to tie and tape the webbing. Tie the front suspension slings to each other in the same way.
- ④ Tie a length of 1/2-inch tubular nylon webbing between the inside shackles of the second and sixth drums and behind the center suspension slings. Make this tie as taut as possible.

Figure 4-90. Suspension slings safetied

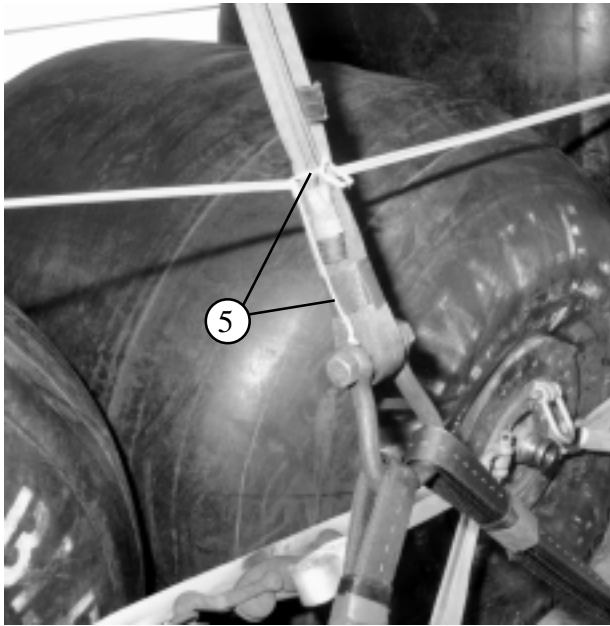

- ⑤ Pass a length of 1/4-inch, type I cotton webbing through the plies of the center suspension slings at the clevis bolt. Pass the ends up and over the 1/2-inch tubular nylon webbing placed in step 4 so that the nylon webbing is kept in a horizontal position. Tie the cotton webbing to the outside of the slings.
- ⑥ Tie the front suspension slings to the upper shackle on the second drum with a length of type III nylon cord. Tie the rear suspension slings to the sixth drum in the same way.

Figure 4-90. Suspension slings safetied (continued)

4-124. Building and Lashing Parachute Stowage Platform

Build the parachute stowage platform and its supports as shown in Figure 4-76, found in Section VIII. Lash the parachute stowage platform to the load as shown in Figure 4-91.

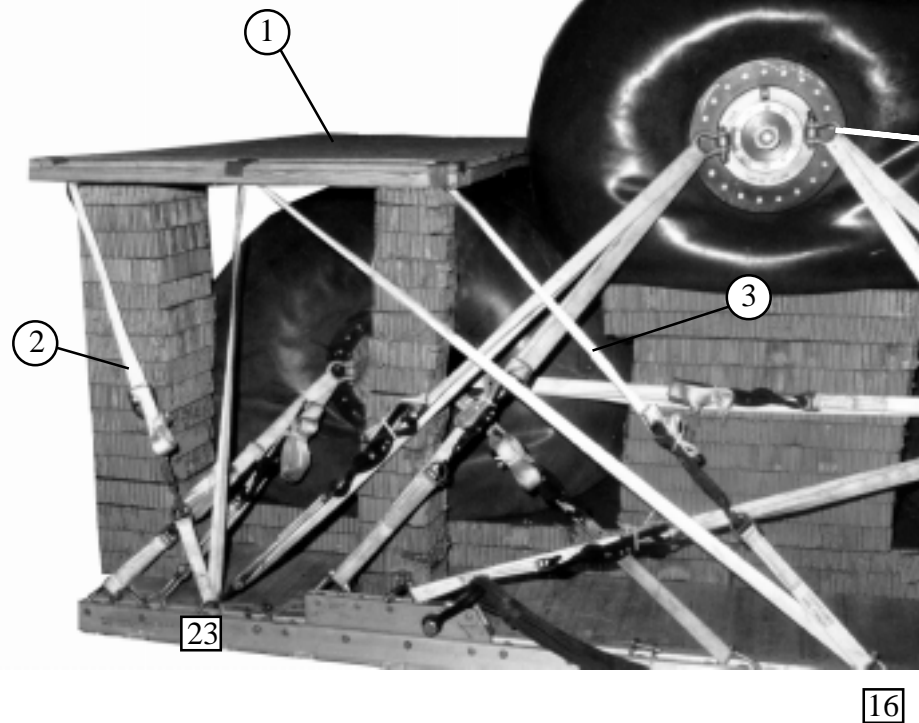

- ① Center the parachute stowage platform on the honeycomb placed in Figure 4-77.
- ② Lash the two rear holes in the parachute stowage platform to clevises 23 and 23A.
- ③ Lash the two front holes in the parachute stowage platform to clevises 16 and 16A.

Figure 4-91. Parachute stowage platform lashed to platform rails

4-125. Installing Cargo Parachutes

Install seven G-11 cargo parachutes as shown in Figure 4-92, and according to FM 10-500-2/TO 13C7-1-5.

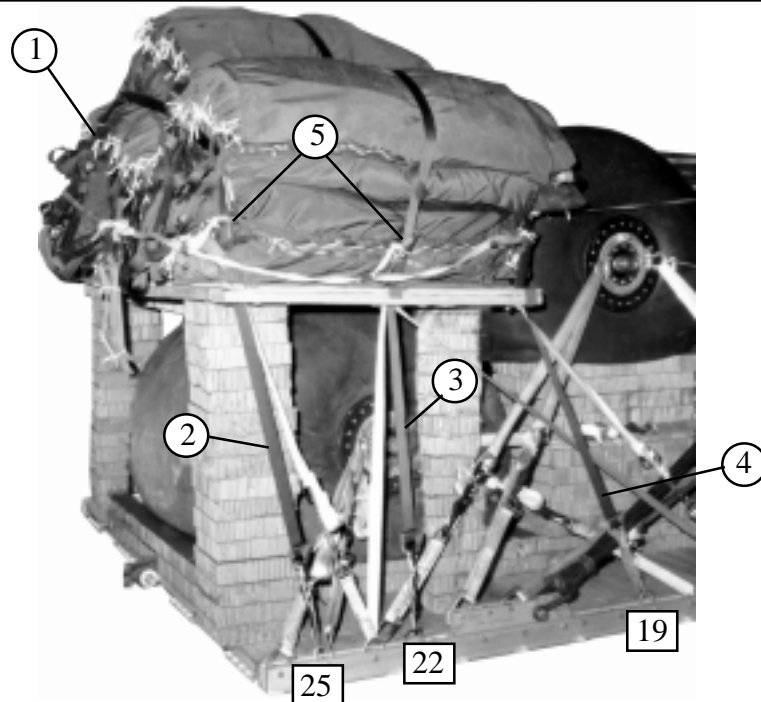

- ① Cluster seven G-11 cargo parachutes on the parachute stowage platform.
- ② Pass the rear restraint strap through the rear holes in the parachute stowage platform, and attach the ends to the lower clevises of 25 and 25A with D-rings and load binders.
- ③ Pass the center restraint strap through the center holes in the parachute stowage platform, and attach the ends to inverted clevises 22 and 22A with D-rings and load binders.
- ④ Pass the front restraint strap through the front holes in the parachute stowage platform, and attach the ends to inverted clevises 19 and 19A with D-rings and load binders.
- ⑤ Install the parachute release knives according to FM 10-500-2/TO 13C7-1-5.

Figure 4-92. G-11 cargo parachutes installed

4-126. Installing Parachute Release

Prepare and install an M-2 cargo parachute release as shown in Figure 4-93, and according to FM 10-500-2/TO 13C7-1-5.

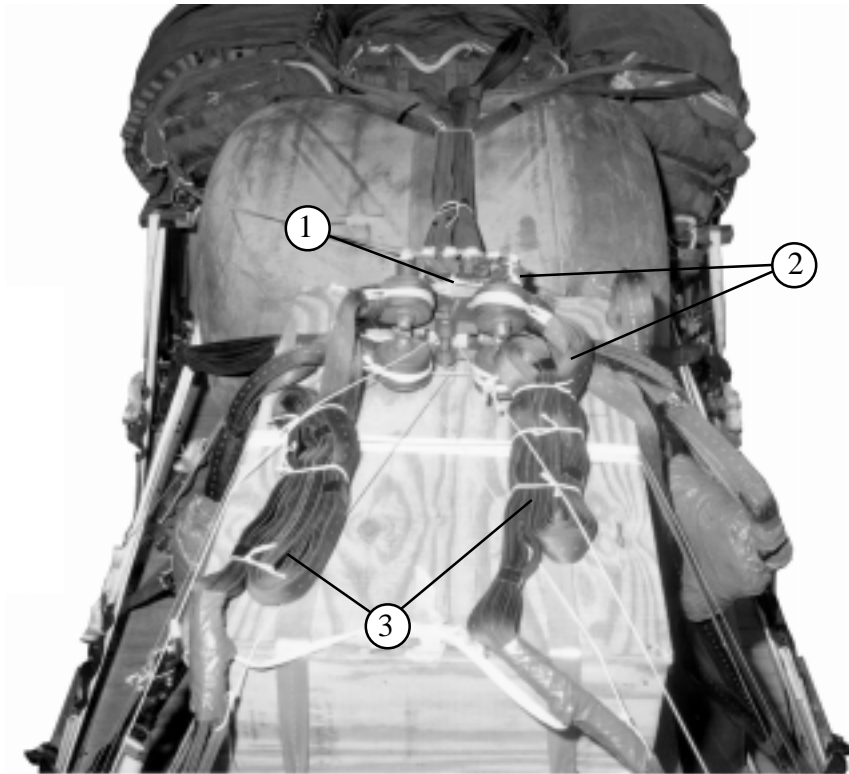

- ① Center the M-2 release assembly on the pump box. Secure the release to the load with type III nylon cord.
- ② Attach the suspension slings and the riser extensions to the M-2 release according to FM 10-500-2/TO 13C7-1-5.
- ③ S-fold the suspension slings and tie the folds with type I, 1/4-inch cotton webbing.

Figure 4-93. M-2 release installed

4-127. Installing Extraction System

Prepare and install the EFTC extraction system as shown in Figure 4-80 in Section VIII, and according to FM 10-500-2/TO 13C7-1-5.

4-128. Installing Provisions for Emergency Restraints

Select and install provisions for emergency restraint according to the emergency aft restraint requirements table in FM 10-500-2/TO 13C7-1-5.

4-129. Placing Extraction Parachute

Select the extraction parachute and extraction line needed using the extraction line requirements table in FM 10-500-2/TO 13C7-1-5. Place the extraction parachute and extraction line on the load for installation in the aircraft.

4-130. Marking Rigged Load

Mark the rigged load according to FM 10-500-2/TO 13C7-1-5 and as shown in Figure 4-94.

CAUTION

The load weight may vary from the one shown, depending upon the fuel rigged. Be sure that the load is weighed, and the parachute requirements, CB, and tip-off curve recomputed.

4-131. Equipment Required

Use the equipment listed in Table 4-9 to rig this load.

CAUTION

**Make the final rigger inspection required by FM 10-500-2/TO 13C7-1-5
before the load leaves the rigging site.**

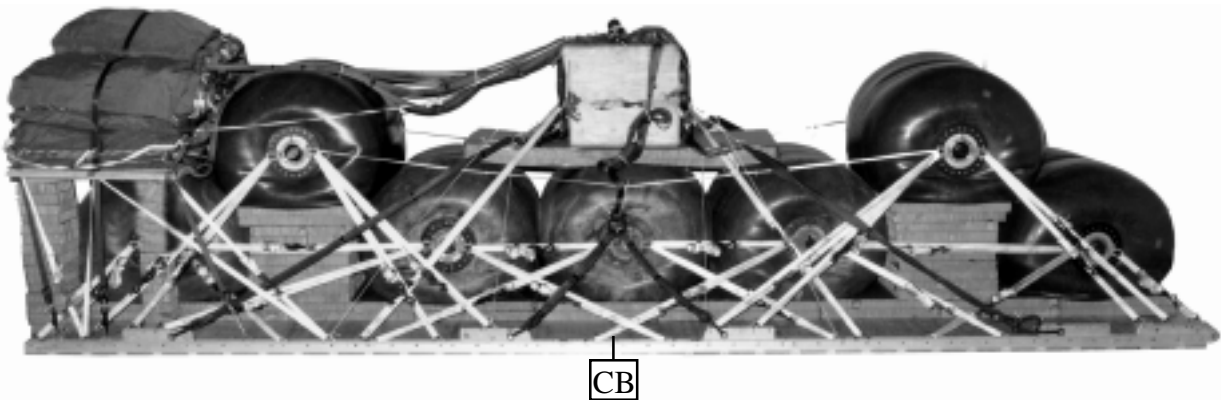
**Rigged Load Data**

Weight: Estimated, with gasoline	25,081 pounds
Maximum (as shown)	32,135 pounds
Height	90 inches
Width	108 inches
Length	336 inches
Overhang Front	5 inches
Rear	17 inches
CB (from front edge of platform)	176 inches
Extraction System (adds 18 inches to length of platform)	EFTC

Figure 4-94. Seven drums with pumping assembly rigged on a 28-foot, type V airdrop platform for low-velocity airdrop

Table 4-9. Equipment required for rigging seven drums with pumping assembly on a 28-foot, type V platform for low-velocity airdrop

National Stock Number	Item	Quantity
8040-00-273-8713	Adhesive, paste, 1-gal	As required
4030-00-678-8562	Clevis, suspension, 3/4-in (medium)	6
4030-00-090-5354	Clevis, suspension, 1-in (large)	18
4020-00-240-2146	Cord, nylon, type III, 550-lb	As required
1670-01-326-7309	Coupling, airdrop, extraction force transfer with cable, 28-ft	1
	Cover:	
1670-00-360-0328	Clevis, large	1
1670-00-360-0329	Link, type IV	8
8305-00-958-3685	Felt, 1/2-in thick	As required
1670-01-183-2678	Leaf, extraction line (line bag)	2
	Line, drogue (for C-17)	
1670-01-062-6316	60-ft (3-loop), type XXVI	1
	Line, extraction:	
1670-01-064-4454	60-ft (6-loop), type XXVI (for C-130)	1
1670-01-062-6312	120-ft (6-loop), type XXVI (for C-141B or C-5)	1
NO NSN	140-ft (6-loop), type XXVI (for C-17)	1
	Link assembly:	
1670-01-3070155	Three-point	2
1670-00-783-5988	Type IV	8
1670-00-006-2752	Four-point	1
	Lumber:	
5510-00-220-6146	2- by 4- by:	
	41 1/2-in	2
	25 1/2-in	2
5510-00-220-6148	2- by 6- by:	
	85-in	2
	48-in	2

Table 4-9. Equipment required for rigging seven drums with pumping assembly on a 28-foot, type V platform for low-velocity airdrop (continued)

National Stock Number	Item	Quantity
5315-00-010-4659	Nail, steel wire, 8d	As required
1670-00-753-3928	Pad, energy-dissipating (honeycomb) 3- by 36- by 96-in	28 sheets
	Parachute:	
	Cargo:	
1670-01-016-7841	G-11C	7
	Cargo extraction:	
1670-00-040-8135	28-ft	2
	Drogue (for C-17)	
1670-01-063-3715	15-ft	1
	Platform, airdrop, type V, 28-ft	
1670-01-353-8425	Bracket assembly, coupling	(1)
1670-01-162-2372	Clevis assembly, type V	(56)
1670-01-162-2376	Extraction bracket assembly	(1)
1670-01-162-2381	Tandem link assembly (Multipurpose link)	(2)
1670-01-247-2389	Suspension link	(8)
5530-00-128-4981	Plywood, 3/4 -by 48- by 96-in	7 sheets
1670-01-097-8817	Release, cargo parachute, M-2	1
	Sling, cargo, airdrop	
	For suspension:	
1670-01-062-6306	3-ft (4-loop), type XXVI nylon webbing	6
1670-01-062-6310	11-ft (4-loop), type XXVI nylon webbing	2
1670-01-063-7761	16-ft (2-loop), type XXVI nylon webbing	2
1670-01-064-4453	20-ft (4-loop), type XXVI nylon webbing	2
	For lifting:	
1670-01-062-6304	9-ft (2-loop), type XXVI nylon webbing	2
	For deployment:	
1670-01-062-6304	9-ft (2-loop), type XXVI nylon webbing	1
	For riser extension:	
1670-01-062-6311	120-ft (2-loop), type XXVI nylon webbing	7

Table 4-9. Equipment required for rigging seven drums with pumping assembly on a 28-foot, type V platform for low-velocity airdrop (continued)

National Stock Number	Item	Quantity
5340-00-040-8219	Strap, parachute release, multi-cut, comes w/ 3 knives	2
7510-00-266-5016	Tape, adhesive, 2-in	As required
1670-00-937-0271	Tie-down assembly, 15-foot	56
	Webbing:	
8305-00-268-2411	Cotton, 1/4-in, type I	As required
8305-00-082-5752	Nylon, tubular, 1/2-in	As required
8305-00-261-8584	Type X	As required

GLOSSARY

ACB	Attitude control bar	JAI	joint airdrop inspector
AFB	Air Force base	JP	jet propulsion
AFJMAN	Air Force Joint Manual	LAPE	low-altitude parachute extraction
AFR	Air Force regulation	LAPES	low-altitude parachute extraction system
AFTO	Air Force technical order	lb	pound
attn	attention	LV	low-velocity
CB	center of balance	NSN	national stock number
d	penny	PEFTC	platform extraction force transfer coupling
DA	Department of the Army	psi	pounds per square inch
DD	Department of Defense	SL/CS	static line/connector strap
diam	diameter	TM	technical manual
EFTA	extraction force transfer actuator	TO	technical order
EFTC	extraction force transfer coupling	TRADOC	US Army Training and Doctrine Command
fig	figure	US	United States
FM	field manual	w	with
ft	foot/feet	yd	yard
gal	gallon		
HQ	headquarters		
in	inch		

REFERENCES

AFR 55-40/AR 59-4

Joint Airdrop Inspection Records, Malfunction Investigations and Activity Reporting.
27 November 1984.

***AFJMAN 24-204/TM 38-250**

Preparing Hazardous Materials for Military Air Shipments. 25 November 1994.

FM 10-500-2/TO 13C7-1-5

Airdrop of Supplies and Equipment: Rigging Airdrop Platforms. 1 November 1990.

**TM 10-1670-208-20&P/
TO 13C3-4-12**

Organizational Maintenance Manual Including Repair Parts and Special Tools List for Platforms, Type II Modular and LAPES/Airdrop Modular.
10 August 1978.

**TM 10-1670-268-20&P/
TO 13C7-52-22**

Organizational Maintenance Manual With Repair Parts and Special Tools List: Type V Airdrop Platform. 1 June 1986.

**TM 10-1670-277-23&P/
TO 13C5-28-2/NAVAIR 13-1-30**

Unit and Intermediate DS Maintenance Manual Including Repair Parts and Special Tools List for Parachute, 28-foot Diam, Extraction.
9 October 1990.

**TM 10-1670-278-23&P/
TO 13C5-26-2/NAVAIR 13-1-27/
TM 01109C-23&P/1**

Unit and Intermediate DS Maintenance Manual Including Repair Parts and Special Tools List for Parachute, Cargo Type, 15-ft Diam, Cargo Extraction.
6 November 1989.

***AFJMAN24-204/TM 38-250 has superseded AFR 71-4/TM 38-250 (15 January 1988). Change 1 reflects this change. The basic manual still references the superseded publication. You may wish to make pen and ink changes to update the old reference citations accordingly.**

**TM 10-1670-279-23&P/
TO 13C5-27-2/
NAVAIR 13-1-28**

Unit and Intermediate DS Maintenance Manual Including Repair Parts and Special Tools List for Parachute, Cargo Type, 22-ft Diam, Cargo Extraction. 30 August 1989.

**TM 10-1670-280-23&P/
TO 13CS-31-2
NAVAIR 13-1-31**

Unit and Intermediate DS Maintenance Manual Including Repair Parts and Special Tools List for Parachute, Cargo Type, G-11A, G-11B, and G-11C. 5 August 1991.

**TM 10-1670-286-20/
TO 13C5-2-41**

Unit Maintenance Manual for Sling/Extraction Line Panel (Including Stowing Procedures). 1 April 1986.

TM 10-4320-202-25P

Operator's, Organizational, Direct Support, and General Support Maintenance Manual: Pumping Assembly, Flammable Liquid, Bulk Transfer, 50-GPM. 21 May 1968.

TM 10-8110-201-14&P

Operator, Organizational, Direct Support, and General Support Maintenance Manual (Including Repair Parts and Special Tools List) for Drums, Fabric, Collapsible, Non-Vented, 500-Gallon, Liquid Fuel. 10 February 1983.

AFTO Form 22

Technical Order Publication Improvement Report

DA Form 2028

Recommended Changes to Publication and Blank Forms. February 1974.

*** Shipper's Declaration
for Dangerous Goods**

Locally procured form

*** Shipper's Declaration for Dangerous Goods has superseded DD Form 1387-2 (February 1982.) Change 1 reflects this change. The basic manual still references the superseded publication. You may wish to make pen and ink changes to update the old reference citations accordingly.**

FM 10-564/TO 13C7-37-1

16 APRIL 1979

By Order of the Secretaries of the Army and the Air Force:

BERNARD W. ROGERS
General, United States Army
Chief of Staff

Official:

J. C. PENNINGTON
Major General, United States Army
The Adjutant General

DISTRIBUTION:

Active Army and USAR: To be distributed in accordance with DA Form 12-34B, Requirements for Airdrop of Supplies and Equipment (Qty rqr block no. 125).

ARNG: To be distributed in accordance with DA Form 12-11A, Requirements for Airdrop of Supplies and Equipment in the Theater of Operations (Qty rqr block no. 95).

Additional copies can be requisitioned from the US Army Adjutant General Publications Center, 2800 Eastern Boulevard, Baltimore, MD 21220.